

Recreational Integer Iterations

Hans Montanus

Ron Westdijk

Preface

Iterations form a large subject of discrete mathematics. Some iterations have a practical mathematical purpose such as numerical methods to find a root of a function. Other iterations seem to have no other purpose than to satisfy our curiosity. Integer iteration can often be stated in a simple way. For instance, for the Collatz iteration everybody can try some starting numbers and observe how the orbits eventually arrive at 1. Despite the simplicity of the Collatz iteration it has not yet been proven that all orbits will arrive at 1. Also other iterations are hard to analyze. Maybe for this reason simple integer iterations trigger our curiosity. Integer iterations are recreational for being comprehensible and for offering an opportunity to search for records such as the largest length of an orbit or the largest element of an orbit.

In the present book we describe eleven recreational integer iterations. Chapter 1 is a small introduction. For historical reasons chapter 2 and 3 are about the divisor sum iteration and the aliquot divisor sum iteration respectively. Chapter 4 is about a variation of the divisor sum iteration. It offers a lot of challenges to search for records of orbit lengths and orbit maximums. A book about recreational integer iterations should certainly contain the Collatz iteration. It is given attention in Chapter 5. The negative Collatz iteration, which is similar to the Collatz iteration for negative integers, is covered in chapter 6. Generalized Collatz versions are briefly considered in chapter 7. In chapter 8 we consider, mostly just for fun, two iterations which to our best knowledge have not been considered in the literature. Chapter 9, 10, 11 and 12 are about the digit reversal iteration, the Kaprekar iteration, the squared digit sum iteration and the digits factorial sum iteration. Since these four iteration are all applied to integers with a limited number of digits, the orbit lengths are limited. As a consequence, all orbits arrive at a cycle. For this reason they do not offer us a never ending challenge to search for records. In the final chapter we will consider an integer iteration based on Pillai's arithmetic function. It offers a rich cycle structure and challenges for numerical research.

As for all our books, the present book is intended for interested high school students, undergraduate Mathematics students and anybody else interested in recreational mathematics. It therefore is written in an informal way. A proof of a theorem will therefore not have the rigidity as in scientific publications. We accept a loose line of argument for the benefit of clarity and simplicity. Citations will not be given for well known concepts such as Euler's totient function. The reader is advised to consult the internet if more information on such topics is desired. Only recent publications and relevant websites will be cited.

February 2025, Hans Montanus, Ron Westdijk

ISBN 978-90-829889-6-3

© 2025, Hans Montanus and Ron Westdijk

Contents

1	Introduction	7
2	Divisor sum	9
2.1	Introduction	9
2.2	Perfect numbers	10
2.3	Superperfect numbers	11
2.4	Approximate perfect numbers	13
2.5	Approximate perfect odd numbers	15
3	Aliquot divisor sum	19
3.1	Introduction	19
3.2	Arithmetic sequences in orbits	20
3.3	Some statistics	21
3.4	Lengthy orbits	24
3.5	Persistent factors	25
3.6	Drivers	27
3.7	Amicable and sociable numbers	30
4	\mathcal{S} function	33
4.1	Introduction	33
4.2	Cycles of the \mathcal{S} function	33
4.3	Statistics of cycle arrivals	35
4.4	Statistics of untouchables	35
4.5	Statistics of distances	37
4.6	Even and odd orbit numbers	39
4.7	Records of maximums	41
4.8	Records of distances	43
4.9	Questions	44

5	Collatz problem	45
5.1	Introduction	45
5.2	Statistics of untouchables	45
5.3	Statistics of distances	46
5.4	Even and odd orbit numbers	48
5.5	Records of maximums	50
5.6	Records of distances	51
5.7	Rows of equal distance	53
5.8	Question	54
6	Negative Collatz	55
6.1	Introduction	55
6.2	Statistics of cycle arrivals	55
6.3	Statistics of untouchables	56
6.4	Statistics of distances	57
6.5	Even and odd orbit numbers	59
6.6	Records of maximums	61
6.7	Records of distances	62
6.8	Question	63
7	Generalised Collatz	65
7.1	Introduction	65
7.2	Cycles for $(3n + 47)/2$ iteration	67
7.3	Period records	68
7.4	Values of w for period 7 cycles	69
7.5	Cycles with a given period	71
7.6	Cycles with $ w = 1$	73
7.7	Further generalization	74
8	\mathcal{M} and \mathcal{W} function	75
8.1	Introduction	75
8.2	Cycles of the \mathcal{M} function	75
8.3	Statistics of cycle arrivals	76
8.4	Approximation for the n -th prime	77
8.5	The \mathcal{W} function	79
8.6	Cycles of the \mathcal{W} function	79
8.7	Statistics of cycle arrivals	80

9	Reversal of digits	81
9.1	Introduction	81
9.2	Reversal of digits for m -digit numbers	82
9.3	Digit reversal iteration in base 2	88
9.4	Digit reversal iteration in base 3	90
9.5	Digit reversal iteration in base b	92
9.6	Digit reversal iteration in base 4 through 9	93
9.7	Periodic cycles	97
10	Kaprekar	99
10.1	Kaprekar's constant	99
10.2	Kaprekar for m -digit numbers	100
10.3	Kaprekar in base 2	102
10.4	Kaprekar in base 3 through 9	104
10.5	Periodic cycles	108
11	Squared digit sum	109
11.1	Introduction	109
11.2	Statistics of cycle arrivals	111
11.3	Statistics of untouchables	111
11.4	Statistics of distances	113
11.5	Other bases	114
11.6	Happy numbers	119
12	Digits factorial sum	121
12.1	Introduction	121
12.2	Cycles of the \mathcal{F} function	122
12.3	Statistics of cycle arrivals	123
12.4	Statistics of untouchables	123
12.5	Statistics of distances	125
12.6	Records of distances	125
12.7	Records of maximums	126
13	\mathcal{P} function	127
13.1	Pillai's function	127
13.2	Cycles of the \mathcal{P} function.	129
13.3	Cycle combinations	130
13.4	Statistics of cycle arrivals	132
13.5	Statistics of untouchables	132
13.6	Statistics of distances	134

13.7 Records of maximums	134
13.8 Records of distances	137
13.9 Successive even numbers	137
Bibliography	141

Chapter 1

Introduction

An iteration is the repetition of a process in order to generate a sequence of successive numbers: the orbit. The first number or first numbers of a sequence are prescribed: the initial condition. A first example of an iteration is

$$n_k = n_{k-1} + k. \quad (1.1)$$

With initial condition $n_0 = 0$ it leads to the sequence $0, 1, 3, 6, 10, 15, 21, 28, 36, \dots$. The orbit for starting value 0 is also generated without iterations by a *closed-form* expression:

$$n_k = \frac{1}{2}k(k+1). \quad (1.2)$$

A second example of an iteration is

$$n_k = n_{k-1} + n_{k-2}. \quad (1.3)$$

With initial condition $n_0 = 0$ and $n_1 = 1$ it leads to the Fibonacci sequence: $0, 1, 1, 2, 3, 5, 8, 13, 21, 34, 55, 89, \dots$. Also this orbit can be generated by a closed-form expression:

$$n_k = \frac{1}{\sqrt{5}} \left(\left(\frac{1 + \sqrt{5}}{2} \right)^k - \left(\frac{1 - \sqrt{5}}{2} \right)^k \right). \quad (1.4)$$

The latter is known as Binet's formula.

A third example of an iteration is

$$n_{k+1} = \begin{cases} \frac{3n_k + 1}{2} & \text{if } n_k \cong 1 \pmod{2} \\ \frac{n_k}{2} & \text{if } n_k \cong 0 \pmod{2} \end{cases} \quad (1.5)$$

where n_k is a positive integer. If we start with $n_0 = 1$ then $n_1 = 2, n_2 = 1, n_3 = 2$ and so on. The period two cycle $(1, 2)$ is called the trivial cycle. If we start with $n_0 = 3$ then $n_1 = 5, n_2 = 8, n_3 = 4, n_4 = 2$, and so on. That is, for starting value $n_0 = 3$ the orbit

arrives after 4 steps at the $(1, 2)$ cycle. To date it has been verified by computer that for each starting values up to about 10^{21} that the orbit arrives at the trivial cycle $(1, 2)$. It therefore is conjectured that for every starting value larger than 0 the orbit will arrive at the trivial cycle. It is known as the Collatz conjecture. The reason for the Collatz conjecture not being proven yet is probably the absence of a suitable closed-form expression for the generation of the sequences. Without a closed-form expression it is notorious difficult to investigate properties in an analytical way. Instead, one investigates properties of Collatz sequences with the aid of the computer. These efforts lead to all kinds of record tables, see [1] and citations therein.

The aim of this book is to investigate properties of integer sequences generated by iterations for which there is no suitable closed-form alternative. For historical reasons we start with the divisor sum iteration and aliquot divisor sum iteration. We try to pay attention also to less known iterations. An example of a less known iteration is

$$n_{k+1} = \frac{\sigma(n_k)}{\gcd(n_k, \sigma(n_k))}, \quad (1.6)$$

where $\sigma(x)$ is the divisor-sum of x and where $\gcd(x, y)$ is the greatest common divisor of x and y . For brevity we will call the underlying function \mathcal{S} :

$$\mathcal{S}(n) = \frac{\sigma(n)}{\gcd(n, \sigma(n))}. \quad (1.7)$$

Another less known iteration is

$$n_{k+1} = \frac{P(n_k)}{\gcd(n_k, P(n_k))}, \quad (1.8)$$

where $P(x)$ is the gcd-sum function also known as Pillai's arithmetical function. For brevity we will call the underlying function \mathcal{P} :

$$\mathcal{P}(n) = \frac{P(n)}{\gcd(n, P(n))}. \quad (1.9)$$

Some properties of iterations will be analyzed algebraically if the analysis is simple and appropriate. For most properties we resort to numerical research. Writing computer code for the investigation of iterations is often considered a recreational effort. It can be performed by amateurs as well as by professionals.

Chapter 2

Divisor sum

2.1 Introduction

A single step iteration based on the sum of divisors is

$$n_{i+1} = \sigma(n_i), \quad (2.1)$$

where $\sigma(n)$ is the sum of the divisors of n :

$$\sigma(n) = \sum_{d|n} d, \quad (2.2)$$

where d runs over all divisors of n including n itself. For instance, for $n = 2$, $n = 3$, $n = 4$, $n = 6$ and $n = 12$ we have $\sigma(2) = 1 + 2 = 3$, $\sigma(3) = 1 + 3 = 4$, $\sigma(4) = 1 + 2 + 4 = 7$, $\sigma(6) = 1 + 2 + 3 = 6 = 12$ and $\sigma(12) = 1 + 2 + 3 + 4 + 6 + 12 = 28$. We see, $\sigma(12) = \sigma(4) \cdot \sigma(3)$, while $\sigma(12) \neq \sigma(2) \cdot \sigma(6)$. In general, if n_1 and n_2 are relative prime, then $\sigma(n_1 \cdot n_2) = \sigma(n_1) \cdot \sigma(n_2)$. If we write the prime factorization of n as

$$n = \prod_{p_k|n} p_k^{\alpha_k}, \quad (2.3)$$

where $\alpha_k \geq 1$ is the largest power of prime p_k for which $p_k^{\alpha_k}$ is a divisor of n , then

$$\sigma(n) = \prod_{p_k|n} \sigma(p_k^{\alpha_k}). \quad (2.4)$$

By means of the identity

$$1 + p + p^2 + \dots + p^m = \frac{p^{m+1} - 1}{p - 1} \quad (2.5)$$

we can write

$$\sigma(p_k^{\alpha_k}) = \frac{p_k^{\alpha_k+1} - 1}{p_k - 1}. \quad (2.6)$$

and thus

$$\sigma(n) = \prod_{p_k|n} \frac{p_k^{\alpha_k+1} - 1}{p_k - 1}. \quad (2.7)$$

For $n = 1, 2, 3, 4, 5, 6, 7, 8, 9, \dots$ the σ values are $1, 3, 4, 7, 6, 12, 8, 15, 13, \dots$. The latter is the sequence A000203 of the OEIS [2].

Since $\sigma(1) = 1$ the number 1 is a fixed point. Since $\sigma(n) > n$ for $n > 1$, the orbits are sequences of increasing numbers for $n > 1$. For instance, the orbit for 2 is $2, 3, 4, 7, 8, 15, \dots$ and the orbit for 5 is $5, 6, 12, 28, 56, \dots$, see the sequences A007497 and A051572 of the OEIS [2].

There exist no integer m such that $\sigma(m) = 2$: the number 2 is ‘untouchable’ or ‘unreachable’. The sequence of untouchable numbers for the map $n \rightarrow \sigma(n)$ is $2, 5, 9, 10, 11, 16, 17, 19, 21, 22, 23, 25, 26, \dots$, see sequence A007369 of the OEIS.

2.2 Perfect numbers

If $\sigma(n) = 2n$ then n is a *perfect* number. The first four perfect numbers are

$$\begin{aligned} 2^1(2^2 - 1) &= 6, \\ 2^2(2^3 - 1) &= 28, \\ 2^4(2^5 - 1) &= 496, \\ 2^6(2^7 - 1) &= 8128. \end{aligned} \quad (2.8)$$

A number of the type $2^{m-1}(2^m - 1)$ is perfect if and only if $2^m - 1$ is prime. For $2^m - 1$ to be prime, m has to be prime. Prime numbers of the form $2^m - 1$ are known as *Mersenne* primes. Primality of m does not guarantee primality of $2^m - 1$. For instance, $2^{11} - 1 = 23 \cdot 89$ is not prime. For the next prime $p = 13$ the number $2^{13} - 1$ is prime. So, $2^{12}(2^{13} - 1) = 33\,550\,336$ is perfect. It is still an open question whether an odd perfect number exists.

If $\sigma(n) = k \cdot n$, with k integer, then n is a k -perfect number. If $k = 2$ then n is perfect and if $k \geq 3$ then n is *multi-perfect*.

Up to 10^9 there are four 3-perfect numbers:

$$\begin{aligned} 2^3 \cdot 3 \cdot 5 &= 120, \\ 2^5 \cdot 3 \cdot 7 &= 672, \\ 2^9 \cdot 3 \cdot 11 \cdot 31 &= 523\,776, \\ 2^8 \cdot 5 \cdot 7 \cdot 19 \cdot 37 \cdot 73 &= 459\,818\,240. \end{aligned} \quad (2.9)$$

Up to 10^9 there are six 4-perfect numbers:

$$\begin{aligned}
 2^5 \cdot 3^3 \cdot 5 \cdot 7 &= 30\,240, \\
 2^3 \cdot 3^2 \cdot 5 \cdot 7 \cdot 13 &= 32\,760, \\
 2^2 \cdot 3^2 \cdot 5 \cdot 7^2 \cdot 13 \cdot 19 &= 2\,178\,540, \\
 2^9 \cdot 3^3 \cdot 5 \cdot 11 \cdot 31 &= 23\,569\,920, \\
 2^7 \cdot 3^3 \cdot 5^2 \cdot 17 \cdot 31 &= 45\,532\,800, \\
 2^9 \cdot 3^2 \cdot 7 \cdot 11 \cdot 13 \cdot 31 &= 142\,990\,848.
 \end{aligned} \tag{2.10}$$

The smallest 5-perfect number is larger than 10^9 :

$$2^7 \cdot 3^4 \cdot 5 \cdot 7 \cdot 11^2 \cdot 17 \cdot 19 = 14\,182\,439\,040. \tag{2.11}$$

Up to 10^9 there are no 6-perfect numbers.

2.3 Superperfect numbers

A two-step iteration of n based on the sum of divisors is $\sigma^{(2)}(n) = \sigma(\sigma(n))$. Also

$$n_{i+2} = \sigma^{(2)}(n_i). \tag{2.12}$$

A number n is *superperfect* if it satisfies the equation

$$\sigma^{(2)}(n) = 2 \cdot n. \tag{2.13}$$

Up to 10^9 there are seven superperfect numbers:

$$\begin{aligned}
 2^1 &= 2, \\
 2^2 &= 4, \\
 2^4 &= 16, \\
 2^6 &= 64, \\
 2^{12} &= 4096, \\
 2^{16} &= 65\,536, \\
 2^{18} &= 262\,144.
 \end{aligned} \tag{2.14}$$

The next superperfect number is $2^{30} = 1\,073\,741\,824$. Each superperfect number above is half times the sum of a Mersenne number and 1. This can be understood as follows: if $n = 2^{p-1}$ then $\sigma(n) = 2^p - 1$. And if $2^p - 1$ is a prime, then $\sigma(\sigma(n)) = \sigma(2^p - 1) = 2^p = 2n$. It is not known if there exists an odd superperfect number.

More general a number n is (2,k)-perfect if it satisfies the equation

$$\sigma^{(2)}(n) = k \cdot n. \tag{2.15}$$

Examples of (2,3)-perfect numbers are

$$\begin{aligned} 2^3 &= 8, \\ 3 \cdot 7 &= 21, \\ 2^9 &= 512. \end{aligned} \tag{2.16}$$

We see that (2,3)-perfect numbers can be odd.

Examples of (2,4)-perfect numbers are

$$\begin{aligned} 3 \cdot 5 &= 15, \\ 3 \cdot 11 \cdot 31 &= 1023, \\ 3 \cdot 7 \cdot 19 \cdot 73 &= 29\,127, \\ 3^3 \cdot 19 \cdot 31 \cdot 2731 \cdot 8191 &= 355\,744\,082\,763. \end{aligned} \tag{2.17}$$

These four (2,4)-perfect numbers are all odd.

To date it is an open question if a (2,5)-perfect number exists.

Examples of (2,6)-perfect numbers are

$$\begin{aligned} 2 \cdot 3 \cdot 7 &= 42, \\ 2^2 \cdot 3 \cdot 7 &= 84, \\ 2^5 \cdot 5 &= 160, \\ 2^4 \cdot 3 \cdot 7 &= 336, \\ 2^6 \cdot 3 \cdot 7 &= 1344, \\ 2^{12} \cdot 3 \cdot 7 &= 86\,016, \\ 3 \cdot 5 \cdot 7 \cdot 13^2 \cdot 31 &= 550\,095, \\ 2^{16} \cdot 3 \cdot 7 &= 1\,376\,256, \\ 2^{18} \cdot 3 \cdot 7 &= 5\,505\,024, \\ 2^{30} \cdot 3 \cdot 7 &= 22\,548\,578\,304. \end{aligned} \tag{2.18}$$

Except for 160 and 550095 the (2,6)-perfect numbers above are of the type $n = 2^{p-1} \cdot 3 \cdot 7$ where $2^p - 1$ is a Mersenne prime. For these n it follows that $\sigma(n) = (2^p - 1) \cdot 2^5$ and $\sigma(\sigma(n)) = \sigma(2^p - 1) \cdot \sigma(2^5) = 2^p \cdot 3^2 \cdot 7 = 6n$.

The odd number, $550\,095 = 3 \cdot 5 \cdot 7 \cdot 13^2 \cdot 31$ is a little bit of interest. If an odd number n is perfect, then n is a (2,6)-perfect number: $\sigma(n) = 2n$ and $\sigma(\sigma(n)) = \sigma(2n) = \sigma(2) \cdot \sigma(n) = 6n$. Although 550095 is (2,6)-perfect, it is not perfect: $\sigma(550095) = 1\,124\,352$, while $2 \cdot 550095 = 1\,100\,190$. The relative deviation is $\frac{1124352 - 1100190}{1100190} \approx 0.021961$.

2.4 Approximate perfect numbers

A number is close to perfect if $\sigma(n) - 2n$ is small but not zero. The smallest deviation occurs for $\|\sigma(n) - 2n\| = 1$. The next to smallest deviation occurs for $\|\sigma(n) - 2n\| = 2$, etc.

Numbers for which $\sigma(n) - 2n = 1$ are called *quasiperfect* numbers. Until today numbers for which $\sigma(n) - 2n = 1$ have not been found.

Numbers for which $\sigma(n) - 2n = -1$ are called *almost perfect* numbers. The only known almost perfect numbers are powers of 2. Indeed, if $n = 2^k$, then $\sigma(n) = 2^{k+1} - 1$ and $\sigma(n) - 2n = 2^{k+1} - 1 - 2 \cdot 2^k = -1$. Until today it is not known if almost perfect odd numbers do exist. It even is not known if an almost perfect number n exist which is not a power of 2.

For numbers of the type

$$n = 2^{m-1} (2^m - 1 - 2k) , \quad (2.19)$$

with $2^m - 1 - 2k$ a prime, we obtain

$$\sigma(n) - 2n = (2^m - 1) (2^m - 2k) - 2^m (2^m - 1 - 2k) = 2k . \quad (2.20)$$

For $k = 0$ it is reduced to the perfect numbers: $n = 2^{m-1} (2^m - 1)$ with $2^m - 1$ a prime.

For $k = 1$ we have $n = 2^{m-1} (2^m - 3)$. If $2^m - 3$ is a prime then $\sigma(n) - 2n = 2$. For instance, for $m = 3$ we have $n = 20$ and $\sigma(20) = 42$. For $m \leq 1000$ the factor $2^m - 3$ is a prime if $m = 3, 4, 5, 6, 9, 10, 12, 14, 20, 22, 24, 29, 94, 116, 122, 150, 174, 213, 221, 233, 266, 336, 452, 545, 689, 694$ and 850 . For $n \leq 10^9$ there are 9 numbers for which $\sigma(n) - 2n = 2$. Among them there are 8 of the type $n = 2^{m-1} (2^m - 3)$. Namely for $m = 3, 4, 5, 6, 9, 10, 12$ and 14 . The exception is the number 650.

For $k = -1$ we have $n = 2^{m-1} (2^m + 1)$. If $2^m + 1$ is a prime then $\sigma(n) - 2n = -2$. For instance, for $m = 1$ we have $n = 3$ and $\sigma(3) = 4$. For $m \leq 1000$ the factor $2^m + 1$ is a prime if $m = 1, 2, 4, 8$ and 16 . For $n \leq 10^9$ there are 4 numbers for which $\sigma(n) - 2n = -2$. All 4 of them are of the type $n = 2^{m-1} (2^m + 1)$. Namely for $m = 1, 2, 4$ and 8 .

For $k = 2$ we have $n = 2^{m-1} (2^m - 5)$. If $2^m - 5$ is a prime then $\sigma(n) - 2n = 4$. For instance, for $m = 3$ we have $n = 12$ and $\sigma(12) = 28$. For $m \leq 1000$ the factor $2^m - 5$ is a prime if $m = 3, 4, 6, 8, 10, 12, 18, 20, 26, 32, 36, 56, 66, 118, 130, 150, 166, 206, 226, 550, 706$ and 810 . For $n \leq 10^9$ there are 10 numbers for which $\sigma(n) - 2n = 4$. Among them there are 6 of the type $n = 2^{m-1} (2^m - 5)$. Namely for $m = 3, 4, 6, 8, 10$ and 12 . The four exceptions are 70, 4030, 5830 and 1 848 964.

For $k = -2$ we have $n = 2^{m-1}(2^m + 3)$. If $2^m + 3$ is a prime then $\sigma(n) - 2n = -4$. For instance, for $m = 1$ we have $n = 5$ and $\sigma(5) = 6$. For $m \leq 1000$ the factor $2^m + 3$ is a prime if $m = 1, 2, 3, 4, 6, 7, 12, 15, 16, 18, 28, 30, 55, 67, 84, 228, 390$ and 784 . For $n \leq 10^9$ there are 14 numbers for which $\sigma(n) - 2n = -4$. Among them there are 8 of the type $n = 2^{m-1}(2^m + 3)$. Namely for $m = 1, 2, 3, 4, 6, 7, 12$ and 15 . The 6 exceptions are $110, 884, 18\,632, 116\,624, 15\,370\,304, 73\,995\,392$.

For $k = 3$ we have $n = 2^{m-1}(2^m - 7)$. If $2^m - 7$ is a prime then $\sigma(n) - 2n = 6$. For instance, for $m = 39$ we have $n = 151\,115\,727\,449\,904\,501\,489\,664$ and $\sigma(n) = 302\,231\,454\,899\,809\,002\,979\,334$. For $m \leq 1000$ the factor $2^m - 7$ is a prime if $m = 39$ and 715 . For $n \leq 10^9$ there are 3 numbers for which $\sigma(n) - 2n = 6$: $8925, 32\,445$ and $442\,365$. None of them there are of the type $n = 2^{m-1}(2^m - 7)$.

For $k = -3$ we have $n = 2^{m-1}(2^m + 5)$. If $2^m + 5$ is a prime then $\sigma(n) - 2n = -6$. For instance, for $m = 1$ we have $n = 7$ and $\sigma(7) = 8$. For $m \leq 1000$ the factor $2^m + 5$ is a prime if $m = 1, 3, 5, 11, 47, 53, 141, 143, 191, 273$ and 341 . For $n \leq 10^9$ there are 8 numbers for which $\sigma(n) - 2n = -6$. Among them there are 4 of the type $n = 2^{m-1}(2^m + 5)$. Namely for $m = 1, 3, 5$ and 11 . The other 4 are $15, 315, 1155, 815\,634\,435$.

For our purpose we will also give the results for $k = 6, k = 28$ and $k = 496$.

For $k = 6$ we have $n = 2^{m-1}(2^m - 13)$. If $2^m - 13$ is a prime then $\sigma(n) - 2n = 12$. For instance, for $m = 4$ we have $n = 24$ and $\sigma(n) = 60$. For $m \leq 20$ the factor $2^m - 13$ is a prime if $m = 4, 5, 9, 13,$ and 17 . The corresponding $n = 2^{m-1}(2^m - 13)$ are $24, 304, 127\,744, 33\,501\,184$ and $8\,589\,082\,624$ respectively.

For $k = 28$ we have $n = 2^{m-1}(2^m - 57)$. If $2^m - 57$ is a prime then $\sigma(n) - 2n = 56$. For instance, for $m = 6$ we have $n = 224$ and $\sigma(n) = 504$. For $m \leq 20$ the factor $2^m - 57$ is a prime if $m = 6, 7, 8, 10, 16$ and 19 . The corresponding $n = 2^{m-1}(2^m - 57)$ are $224, 4544, 25\,472, 495\,104, 2\,145\,615\,872$ and $137\,424\,011\,264$ respectively.

For $k = 496$ we have $n = 2^{m-1}(2^m - 993)$. If $2^m - 993$ is a prime then $\sigma(n) - 2n = 992$. For instance, for $m = 10$ we have $n = 15872$ and $\sigma(n) = 32736$. For $m \leq 20$ the factor $2^m - 993$ is a prime if $m = 10, 14$ and 17 . The corresponding $n = 2^{m-1}(2^m - 993)$ are $15\,872, 126\,083\,072$ and $8\,524\,857\,344$ respectively.

The reason for the latter three k values is that for k a perfect number the relation $\sigma(n) - 2n = 2k$ can also be achieved by numbers which are a product of a perfect number k and a prime

which is co-prime to k . That is, if

$$n = 2^{m-1} (2^m - 1) p, \quad (2.21)$$

with $2^m - 1$ a prime and p a prime, we obtain

$$\sigma(n) - 2n = 2^m (2^m - 1) (p + 1) - 2 \cdot 2^{m-1} (2^m - 1) p = 2 \cdot 2^{m-1} (2^m - 1). \quad (2.22)$$

Indeed, for $k = 2^{m-1} (2^m - 1)$ we have $\sigma(n) - 2n = 2k$.

In the next chapter we will further investigate this type of numbers.

For now, it is sufficient to see that all foregoing approximate perfect n in the series $n = 2^k$, $n = 2^{m-1} (2^m - 1 - 2k)$ or $n = 2^{m-1} (2^m - 1) p$ are all even.

2.5 Approximate perfect odd numbers

Odd numbers n for which $\sigma(n)$ is close to $2n$ are approximately perfect. The relative deviation

$$\delta(n) = \frac{\|\sigma(n) - 2n\|}{2n} \quad (2.23)$$

is used as a measure for the accuracy of the approximate perfection. The relative deviation is also called the relative abundance. For increasing odd n the first 40 records of approximate perfection are shown in the next table.

#	n	$2n$	$\sigma(n)$	$\sigma(n) - 2n$	$\delta(n)$
1	1	2	1	-1	$5.0000 \cdot 10^{-1}$
2	3	6	4	-2	$3.3333 \cdot 10^{-1}$
3	9	18	13	-5	$2.7778 \cdot 10^{-1}$
4	15	30	24	-6	$2.0000 \cdot 10^{-1}$
5	45	90	78	-12	$1.3333 \cdot 10^{-1}$
6	105	210	192	-18	$8.5714 \cdot 10^{-2}$
7	315	630	624	-6	$9.5238 \cdot 10^{-3}$
8	1155	2310	2304	-6	$2.5974 \cdot 10^{-3}$
9	7425	14850	14880	30	$2.0202 \cdot 10^{-3}$
10	8415	16830	16848	18	$1.0695 \cdot 10^{-3}$
11	8925	17850	17856	6	$3.3613 \cdot 10^{-4}$
12	31815	63630	63648	18	$2.8289 \cdot 10^{-4}$

#	n	$2n$	$\sigma(n)$	$\sigma(n) - 2n$	$\delta(n)$
13	32445	64890	64896	6	$9.2464 \cdot 10^{-5}$
14	351351	702702	702720	18	$2.5615 \cdot 10^{-5}$
15	442365	884730	884736	6	$6.7817 \cdot 10^{-6}$
16	13800465	27600930	27600768	-162	$5.8694 \cdot 10^{-6}$
17	14571585	29143170	29143296	126	$4.3235 \cdot 10^{-6}$
18	16286445	32572890	32572800	-90	$2.7630 \cdot 10^{-6}$
19	20355825	40711650	40711680	30	$7.3689 \cdot 10^{-7}$
20	20487159	40974318	40974336	18	$4.3930 \cdot 10^{-7}$
21	78524145	157048290	157048320	30	$1.9102 \cdot 10^{-7}$
22	132701205	265402410	265402368	-42	$1.5825 \cdot 10^{-7}$
23	159030135	318060270	318060288	18	$5.6593 \cdot 10^{-8}$
24	815634435	1631268870	1631268864	-6	$3.6781 \cdot 10^{-9}$
25	2586415095	5172830190	5172830208	18	$3.4797 \cdot 10^{-9}$
26	29169504045	58339008090	58339008000	-90	$1.5427 \cdot 10^{-9}$
27	40833636525	81667273050	81667272960	-90	$1.1020 \cdot 10^{-9}$
28	125208115065	250416230130	250416230400	270	$1.0782 \cdot 10^{-9}$
29	127595519865	255191039730	255191040000	270	$1.0580 \cdot 10^{-9}$
30	154063853475	308127706950	308127707136	186	$6.0365 \cdot 10^{-10}$
31	295612416135	591224832270	591224832000	-270	$4.5668 \cdot 10^{-10}$
32	394247024535	788494049070	788494049280	210	$2.6633 \cdot 10^{-10}$
33	636988686495	1273977372990	1273977372672	-318	$2.4961 \cdot 10^{-10}$
34	660733931655	1321467863310	1321467863040	-270	$2.0432 \cdot 10^{-10}$
35	724387847085	1448775694170	1448775694080	-90	$6.2121 \cdot 10^{-11}$
36	740099543085	1480199086170	1480199086080	-90	$6.0803 \cdot 10^{-11}$
37	1707894294975	3415788589950	3415788589824	-126	$3.6888 \cdot 10^{-11}$
38	3521313695835	7042627391670	7042627391904	234	$3.3226 \cdot 10^{-11}$
39	4439852974095	8879705948190	8879705948160	-30	$3.3785 \cdot 10^{-12}$
40	7454198513685	14908397027370	14908397027328	-42	$2.8172 \cdot 10^{-12}$

The list with records continuous. For the first 66 records we refer to a table of M. Alekseyev and A. Violette, see sequence A171929 of the OEIS [2].

If n is an odd perfect number, then $\sigma(n)$ should be divisible by 2 but not divisible by 4. If we impose the condition of $\sigma(n)$ not to be a multiple of 4 in addition to the condition of n to be odd, then the approximate perfection records are as shown in the next table.

#	n	$2n$	$\sigma(n)$	$\sigma(n) - 2n$	$\delta(n)$
1	5	10	6	-4	$4.0000 \cdot 10^{-1}$
2	45	90	78	-12	$1.3333 \cdot 10^{-1}$
3	405	810	726	-84	$1.0370 \cdot 10^{-1}$
4	2205	4410	4446	36	$8.1633 \cdot 10^{-3}$
5	26325	52650	52514	-136	$2.5831 \cdot 10^{-3}$
6	236925	473850	474362	512	$1.0805 \cdot 10^{-3}$
7	1380825	2761650	2763774	2124	$7.6911 \cdot 10^{-4}$
8	1660725	3321450	3323138	1688	$5.0821 \cdot 10^{-4}$
9	35698725	71397450	71396534	-916	$1.2830 \cdot 10^{-5}$
10	3138290325	6276580650	6276530754	-49896	$7.9496 \cdot 10^{-6}$
11	29891138805	59782277610	59782371990	94380	$1.5787 \cdot 10^{-6}$
12	73846750725	147693501450	147693652470	151020	$1.0225 \cdot 10^{-6}$
13	194401220013	388802440026	388802820042	380016	$9.7740 \cdot 10^{-7}$
14	194509436121	389018872242	389019242430	370188	$9.5159 \cdot 10^{-7}$
15	194581580193	389163160386	389163524022	363636	$9.3440 \cdot 10^{-7}$
16	194689796301	389379592602	389379946410	353808	$9.0865 \cdot 10^{-7}$
17	194798012409	389596024818	389596368798	343980	$8.8291 \cdot 10^{-7}$
18	194906228517	389812457034	389812791186	334152	$8.5721 \cdot 10^{-7}$
19	194942300553	389884601106	389884931982	330876	$8.4865 \cdot 10^{-7}$
20	195230876841	390461753682	390462058350	304668	$7.8028 \cdot 10^{-7}$
21	195339092949	390678185898	390678480738	294840	$7.5469 \cdot 10^{-7}$
22	195447309057	390894618114	390894903126	285012	$7.2913 \cdot 10^{-7}$
23	195699813309	391399626618	391399888698	262080	$6.6960 \cdot 10^{-7}$
24	195808029417	391616058834	391616311086	252252	$6.4413 \cdot 10^{-7}$
25	196024461633	392048923266	392049155862	232596	$5.9328 \cdot 10^{-7}$

#	n	$\sigma(n)$	$\sigma(n) - 2n$	$\delta(n)$
26	196204821813	392409859842	216216	$5.5100 \cdot 10^{-7}$
27	196349109957	392698423026	203112	$5.1722 \cdot 10^{-7}$
28	196745902353	393491971782	167076	$4.2460 \cdot 10^{-7}$
29	196781974389	393564112578	163800	$4.1620 \cdot 10^{-7}$
30	196962334569	393924816558	147420	$3.7423 \cdot 10^{-7}$
31	197323054929	394646224518	114660	$2.9054 \cdot 10^{-7}$
32	197431271037	394862646906	104832	$2.6549 \cdot 10^{-7}$
33	197755919361	395511914070	75348	$1.9051 \cdot 10^{-7}$
34	197828063433	395656195662	68796	$1.7388 \cdot 10^{-7}$
35	198044495649	396089040438	49140	$1.2406 \cdot 10^{-7}$
36	198188783793	396377603622	36036	$9.0913 \cdot 10^{-8}$
37	198369143973	396738307602	19656	$4.9544 \cdot 10^{-8}$
38	198513432117	397026870786	6552	$1.6503 \cdot 10^{-8}$
39	283665529390725	567331057322850	-729300	$1.2855 \cdot 10^{-9}$

The numbers 45, 405, 2205, 26325, ... in the second column form the sequence A228059 of the OEIS.

In practice the condition that the divisor sum of a number n should be divisible by 2 but not divisible by 4 means that n is of the form $p^{4j+1} \cdot r^2$, where r^2 is the square part of n and where p is a prime of the form $4k + 1$ with j and k non-negative integers. For an impression the first nine numbers in the second column and factorized in the form $p^{4j+1} \cdot r^2$, see below.

$$\begin{aligned}
 5 &= 5^1 \cdot (1)^2 \\
 45 &= 5^1 \cdot (3^1)^2 \\
 405 &= 5^1 \cdot (3^2)^2 \\
 2205 &= 5^1 \cdot (3^1 \cdot 7^1)^2 \\
 26\,325 &= 13^1 \cdot (3^2 \cdot 5^1)^2 \\
 236\,925 &= 13^1 \cdot (3^3 \cdot 5^1)^2 \\
 1\,380\,825 &= 17^1 \cdot (3^1 \cdot 5^1 \cdot 19^1)^2 \\
 1\,660\,725 &= 61^1 \cdot (3^1 \cdot 5^1 \cdot 11^1)^2 \\
 35\,698\,725 &= 61^1 \cdot (3^2 \cdot 5^1 \cdot 17^1)^2
 \end{aligned}$$

Chapter 3

Aliquot divisor sum

3.1 Introduction

Aliquot divisors of an integer n are divisors of n except n itself. For instance, the aliquot divisors of 12 are 1, 2, 3, 4 and 6. The sum of aliquot divisors of n is denoted as $s(n)$. It is just the divisor sum of n minus n :

$$s(n) = \sigma(n) - n, \quad (3.1)$$

where $\sigma(n)$ is the usual divisor sum of n as we already have met before.

An iteration based on the sum of aliquot divisors is

$$n_{k+1} = s(n_k). \quad (3.2)$$

With initial condition $n_0 = 1$ it leads to the sequence 1, 0. The sequence is terminated when it arrives at 0 since $s(0)$ is undefined. The initial condition $n_0 = 2$ leads to the sequence 2, 1, 0. The initial condition $n_0 = 3$ leads to the sequence 3, 1, 0. The initial condition $n_0 = 4$ leads to the sequence 4, 3, 1, 0. The initial condition $n_0 = 5$ leads to the sequence 5, 1, 0. The initial condition $n_0 = 6$ leads to the sequence 6, 6, 6, That is, 6 is a fixed point. In general, n is a fixed point if $s(n) = n$. The *perfect number* property $s(n) = n$ is equivalent to the property $\sigma(n) = 2n$. So, the fixed points of the iteration $n_{k+1} = s(n_k)$ are perfect numbers. The property $s(n) = (k - 1) \cdot n$ is equivalent to the property $\sigma(n) = k \cdot n$ and it defines a multi-perfect number for $k > 2$.

Sometimes an orbit seems to be infinitely long in the sense that it seems to arrive neither at a periodic cycle nor at 0. For instance for 276 the orbit goes as 276, 396, 696, 1104, 1872, 3770, 3790, 3050, 2716, 2772, 5964, 10 164, 19 628, ... After 800 steps the orbit of 276 is at the 81 digit number 359365395338503080287901208213182053967105084900064321775191103706183295245088746.

The first 800 numbers of the orbit of 276 are even.

Other numbers for which the orbit seems to have infinite length are 306, 396, 552, 564, 660, 696, 780, 828, 888, 966, 1074, 1086, 1098, 1104, 1134, 1218, 1302, 1314, 1320, 1338, ... , see sequence A131884 of the OEIS [2].

Some numbers cannot be the sum of aliquot divisors; they are untouchable. The list of untouchables for $s(n)$ is 2, 5, 52, 88, 96, 120, 124, 146, 162, 188, 206, 210, 216, ..., see sequence A005114 of the OEIS. It is an open question whether 5 is the only odd untouchable for $s(n)$.

3.2 Arithmetic sequences in orbits

Let n be a product of a perfect number and a prime which is co-prime to the perfect number. That is, let

$$n = 2^{m-1} (2^m - 1) \cdot p, \quad (3.3)$$

where $2^m - 1$ is prime and where p is a prime satisfying $\gcd(2^{m-1} (2^m - 1), p) = 1$. As already shown in the previous chapter, for such n there holds

$$\sigma(n) = \sigma(2^{m-1}) \cdot \sigma(2^m - 1) \cdot \sigma(p) = (2^m - 1)2^m \cdot (p + 1). \quad (3.4)$$

As a consequence

$$\begin{aligned} s(n) &= \sigma(n) - n = (2^m - 1)2^{m-1}(2p + 2) - 2^{m-1}(2^m - 1) \cdot p \\ &= 2^{m-1}(2^m - 1)(p + 2) = n + 2^m(2^m - 1). \end{aligned} \quad (3.5)$$

That is, the successor of n is twice a perfect number larger than n . If $p + 2$ also is a prime and co-prime to the perfect number, we can repeat the procedure and we obtain that the successor of $s(n)$ is twice the perfect number larger than $s(n)$. We then have an arithmetic sequence of three successive orbit numbers with twice the perfect number as constant difference.

The first example is for $m = 2$. Since p cannot be 2 or 3, we start with $p = 5$. Then $n = 6 \cdot 5 = 30$, $s(30) = 30 + 12 = 42$. Since $5 + 2 = 7$ is a prime and co-prime to 6, we have $s^{(2)}(30) = s(s(30)) = s(42) = 42 + 12 = 54$. The next prime co-prime to 6 is 11. So, $s(66) = 6 \cdot (11 + 2) = 78$. Since $11 + 2 = 13$ is a prime, we have $s^{(2)}(66) = s(s(66)) = s(78) = 78 + 12 = 90$. The full orbit of 30 goes as: 30, 42, 54, 66, 78, 90, 144, 259, 45, 33, 15, 9, 4, 3, 1, 0. Since $s(54)$ happens to be 66 we have in the orbit starting with 30 an arithmetic sequence of six numbers: 30, 42, 54, 66, 78 and 90.

The second example is for $m = 3$. Since p cannot be 2 or 7, we start with $p = 3$. Then $n = 28 \cdot 3 = 84$, $s(84) = 84 + 56 = 140$. Since $3 + 2 = 5$ is a prime and co-prime to 28, we

have $s^{(2)}(84) = s(s(84)) = s(140) = 140 + 56 = 196$. Since $5 + 2 = 7$ is not co-prime to 28, we cannot repeat the procedure. And since $s(196) = 203$ is not 56 larger than 196, the arithmetic sequence in the orbit 84, 140, 196, 203, 37, 1 consists of the three numbers 84, 140 and 196. Next we try $p = 11$. Then $n = 28 \cdot 11 = 308$, $s(308) = 308 + 56 = 364$. Since $11 + 2 = 13$ is a prime co-prime to 28, we have $s^{(2)}(308) = s(s(308)) = s(364) = 364 + 56 = 420$. Since 420 does not happen to be 56 larger than 420, the arithmetic sequence consists of three numbers: 308, 364 and 420.

The next example is for $m = 5$. Since p cannot be 2 or 31, we start with $p = 3$. Then $n = 496 \cdot 3 = 1488$, $s(1488) = 1488 + 992 = 2480$. Since $3 + 2 = 5$ is a prime and co-prime to 496, we have $s^{(2)}(1488) = s(2480) = 2480 + 992 = 3472$. Since $5 + 2 = 7$ is a prime and co-prime to 496, we have $s^{(3)}(1488) = s(3472) = 3472 + 992 = 4464$. Since $s(4464) = 8432$ is not 992 larger than 4464, the arithmetic sequence consists of four numbers: 1488, 2480, 3472 and 4464.

Of course, by taking other perfect numbers and or other primes we can create many examples of arithmetic triples in orbits for the aliquot divisor sum.

Numerical inspection of orbits starting with $n \leq 10^9$ delivers no arithmetic sequence longer than 5 numbers other than the sequence 30, 42, 54, 66, 78, 90. So, for the aliquot divisor sum iteration the sequence 30, 42, 54, 66, 78, 90 probably is the largest arithmetic sequence.

In the previous chapter we saw that numbers of the type $n = 2^{m-1}(2^m - 1 - 2k)$ with k a perfect number and $2^m - 1 - 2k$ a prime, also does satisfy $\sigma(n) - 2n = 2k$ and thus $s(n) - n = 2k$.

3.3 Some statistics

Among the numbers 1 through 10^9 there are 9 327 005 numbers whose successor is 12 larger. There are 9 327 002 primes p such that $6p \leq 10^9$. Since the primes 2 and 3 are not allowed for p there are 9 327 000 numbers of the type $6p$ below 10^9 . There are 4 numbers of the type $2^{m-1}(2^m - 13)$: 24, 304, 127 744 and 33 501 184. The remaining number is 54.

Among the numbers 1 through 10^9 there are 2 187 839 numbers whose successor is 56 larger. There are 2 187 829 primes p such that $28p \leq 10^9$. Since the primes 2 and 7 are not allowed for p there are 2 187 827 numbers of the type $28p$ below 10^9 . Of the remaining 12 numbers there are 4 numbers of the type $2^{m-1}(2^m - 57)$: 224, 4544, 25 472 and 495 104. The other 8 numbers are 1372, 9272, 14 552, 74 992, 6 019 264, 15 317 696, 35 019 968 and 53 032 832.

Among the numbers 1 through 10^9 there are 150 093 numbers whose successor is 992 larger.

There are 150 065 primes p such that $496p \leq 10^9$. Since the primes 2 and 31 are not allowed for p there are 150 063 numbers of the type $496p$ below 10^9 . Of the remaining 30 numbers there are 2 numbers of the type $2^{m-1}(2^m - 993)$: 15 872 and 126 083 072. The other 28 numbers are 2892, 6104, 170 612, ..., 524 187 392.

Among the numbers 1 through 10^9 there are 11 582 numbers whose successor is 16 256 larger. There are 11 567 primes p such that $8128p \leq 10^9$. Since the primes 2 and 127 are not allowed for p there are 11 565 numbers of the type $8128p$ below 10^9 . Of the remaining 17 numbers there is one number of the type $2^{m-1}(2^m - 16257)$: 1 040 384. The other 16 numbers are 48 684, 112 952, 353 672, 396 112, ..., 855 935 072.

Among the numbers 1 through 10^9 there are 9 numbers whose successor is 67 100 672 larger. There are 10 primes p such that $33550336p \leq 10^9$. The primes 2 and 8191 are not allowed for p , however 8191 already is lower than $10^9/33550336$. As a net result there are 9 numbers below 10^9 whose successor is 67 100 672 larger, which are all of the type $33550336p$.

Hereafter, we will denote the number of $n \leq x$ for which $s(n) = n + 12$ as $\alpha_{12}(x)$, and the number of $n \leq x$ for which $s(n) = n + 56$ as $\alpha_{56}(x)$, etc. As we saw, the contributions to $\alpha_{12}(x)$ by numbers not of the type $6p$ are practically negligible. Hence, $\alpha_{12}(x)$ is approximately given by the number of primes $\leq x/6$. A sufficiently good approximation for the number of primes $\leq x$ is

$$\mu(x) = \frac{x}{\ln x} \left(1 + \frac{1}{\ln x} \right). \quad (3.6)$$

All together, we get

$$\alpha_{12}(x) \approx \frac{x/6}{\ln(x/6)} \left(1 + \frac{1}{\ln(x/6)} \right). \quad (3.7)$$

For $x = 10^9$ we have

$$\alpha_{12}(10^9) \approx \frac{10^9/6}{\ln(10^9/6)} \left(1 + \frac{1}{\ln(10^9/6)} \right) \approx 9.27 \cdot 10^6. \quad (3.8)$$

It deviates less than 1% from the actual value 9 237 005.

A similar calculation leads to the following approximations:

$$\alpha_{56}(10^9) \approx \frac{10^9/28}{\ln(10^9/28)} \left(1 + \frac{1}{\ln(10^9/28)} \right) \approx 2.17 \cdot 10^6, \quad (3.9)$$

which deviates less than 1% from the actual value 2 187 839.

$$\alpha_{992}(10^9) \approx \frac{10^9/496}{\ln(10^9/496)} \left(1 + \frac{1}{\ln(10^9/496)} \right) \approx 1.485 \cdot 10^5, \quad (3.10)$$

which deviates 1.1% from the actual value 150 093.

$$\alpha_{16256}(10^9) \approx \frac{10^9/8128}{\ln(10^9/8128)} \left(1 + \frac{1}{\ln(10^9/8128)} \right) \approx 1.14 \cdot 10^4, \quad (3.11)$$

which deviates 1.6% from the actual value 11 582.

For the ratios we get

$$\frac{\alpha_{12}(10^9)}{\alpha_{56}(10^9)} = \frac{9327005}{2187839} \approx 4.263, \quad (3.12)$$

$$\frac{\alpha_{56}(10^9)}{\alpha_{992}(10^9)} = \frac{2187839}{150093} \approx 14.58, \quad (3.13)$$

$$\frac{\alpha_{992}(10^9)}{\alpha_{16256}(10^9)} = \frac{150093}{11582} \approx 12.96, \quad (3.14)$$

By means of the approximate prime counting function we would have got

$$\frac{\alpha_{12}(10^9)}{\alpha_{56}(10^9)} \approx \frac{\mu(10^9/6)}{\mu(10^9/28)} \approx 4.268, \quad (3.15)$$

$$\frac{\alpha_{56}(10^9)}{\alpha_{992}(10^9)} \approx \frac{\mu(10^9/28)}{\mu(10^9/496)} \approx 14.63, \quad (3.16)$$

$$\frac{\alpha_{992}(10^9)}{\alpha_{16256}(10^9)} \approx \frac{\mu(10^9/496)}{\mu(10^9/8128)} \approx 13.03, \quad (3.17)$$

In the limit where $x \rightarrow \infty$ we obtain

$$\lim_{x \rightarrow \infty} \frac{\alpha_{12}(x)}{\alpha_{56}(x)} \approx \lim_{x \rightarrow \infty} \frac{\mu(x/6)}{\mu(x/28)} = \frac{28}{6} \approx 4.667, \quad (3.18)$$

$$\lim_{x \rightarrow \infty} \frac{\alpha_{56}(x)}{\alpha_{992}(x)} \approx \lim_{x \rightarrow \infty} \frac{\mu(x/28)}{\mu(x/496)} = \frac{496}{28} \approx 17.71, \quad (3.19)$$

$$\lim_{x \rightarrow \infty} \frac{\alpha_{992}(x)}{\alpha_{16256}(x)} \approx \lim_{x \rightarrow \infty} \frac{\mu(x/496)}{\mu(x/8128)} = \frac{8128}{496} \approx 16.39. \quad (3.20)$$

Between 10^9 and ∞ the ratio α_{12}/α_{56} slightly increases from 4.26 to 4.67, the ratio α_{56}/α_{992} slightly increases from 14.6 to 17.7, and the ratio $\alpha_{992}/\alpha_{16256}$ slightly increases from 13.0 to 16.4. The ratios being more or less independent of x makes them useful as indicators for the randomness of the occurrences of properties $s(n) = n + 12$, $s(n) = n + 56$, etc. If these properties occur more or less random, then one might expect the ratios will be reflected in the numbers of a lengthy orbit. As we will see in the next section the statistics in lengthy orbits are remarkably different.

3.4 Lengthy orbits

For the investigation of lengthy orbits we will confine to orbits which do not merge with a lengthy orbit with smaller starting number or are part of another orbit. Of course, for as far as we can inspect. To be specific, the orbit of 306 merges with the orbit of 276, the orbit of 396 is part of the orbit of 276, the orbit of 696 merges with the orbit of 276, the orbit of 780 is part of the orbit of 564, the orbit of 828 merges with the orbit of 660, the orbit of 888 is part of the orbit of 552, the orbits of 1086 and 1098 are part of the orbit of 1074, the orbit of 1104 is part of the orbit of 276, the orbits of 1218 and 1302 merge with the orbit of 1134, the orbit of 1314 merges with the orbit of 564, the orbit of 1320 is part of the orbit of 1074, the orbits of 1338 and 1350 are part of the orbit of 966, the orbit of 1356 is part of the orbit of 660, the orbit of 1392 is part of the orbit of 552 and the orbit of 1410 merges with the orbit of 966. As a consequence, the first eight lengthy orbits suited for investigation are 276, 552, 564, 660, 966, 1074, 1134 and 1464.

In the orbit of 276 there are numbers whose successor is 56 larger. As an example, if $n_0 = 276$ then $n_8 = 2716$ and its successor is $n_9 = 2772$. For $k \leq 800$ the n_k for which $n_{k+1} = n_k + 56$ are given in the next table.

k	n_k
8	2716
12	19 628
19	54 628
23	465 668
24	465 724
42	4 946 860 492
44	9 344 070 652
49	27 410 152 084
67	5 641 400 009 252
68	5 641 400 009 308
79	2 556 878 765 995 204
94	13 780 400 058 385 352 252
96	14 272 557 426 581 383 244
129	553 006 807 242 922 594 628 276
139	1 590 495 621 615 121 371 199 252
157	1 825 045 749 999 763 720 560 245 492
770	15519053469409445075122600866343140070463822047551313401831800906126348266868
788	458489890858162966848272193721941844164128303706788715232527676570255647679924

All the eighteen n_k in the table are of the type $28p$. Since n_{23} and n_{24} are successive orbit numbers and n_{67} and n_{68} are successive orbit numbers, the orbit contains two triples with constant difference 56: (465 668, 465 724, 465 780) and (5 641 400 009 252, 5 641 400 009 308, 5 641 400 009 364). For $k \leq 800$ there are no numbers of the type $6p$ or $496p$. Hereafter we will not mention absent type of orbit numbers.

In the orbit of 552 there are for $k \leq 728$ eleven numbers whose successor is 56 larger. They are all of the type $28p$.

In the orbit of 564 there is for $k \leq 1000$ only one orbit number whose successor is 56 larger. It is of the type $28p$. For $k \leq 1000$ there are eleven numbers in the orbit of 564 whose successor is 12 larger. They are all of the type $6p$. In the orbit of 660 there are for $k \leq 364$ two numbers whose successor is 12 larger. Both are of the type $6p$. For $k \leq 364$ there are two numbers in the orbit of 660 whose successor is 56 larger. Both are of the type $28p$.

In the orbit of 966 there are for $k \leq 380$ five numbers whose successor is 12 larger. They are of the type $6p$. Two of them, n_{18} and n_{19} , are successive orbit numbers. Therefore the orbit contains a triple with constant difference 12: (82 254, 82 266, 82 278). In the orbit of 966 there are for $k \leq 380$ six numbers whose successor is 56 larger. They are all of the type $28p$.

In the orbit of 1074 there are for $k \leq 1000$ six numbers whose successor is 12 larger. They are all of the type $6p$. Since n_0 and n_1 are successive orbit numbers, the orbit contains a triple with constant difference 12: (1074, 1086, 1098). For $k \leq 1000$ there are eight numbers in the orbit of 1074 whose successor is 56 larger. They are all of the type $28p$. For $k \leq 1000$ there are four numbers in the orbit of 1074 whose successor is 992 larger. They are all of the type $496p$.

In the orbit of 1134 there are for $k \leq 750$ eleven numbers whose successor is 12 larger. They are all of the type $6p$.

In the orbit of 1464 there are for $k \leq 1600$ six numbers whose successor is 12 larger. They are all of the type $6p$. For $k \leq 1600$ there are ten numbers in the orbit of 1464 whose successor is 56 larger. They are all of the type $28p$. For $k \leq 1600$ there are five numbers in the orbit of 1464 whose successor is 992 larger. They are all of the type $496p$.

3.5 Persistent factors

By inspection of the orbit starting with 276 we found that 255 out of the first 801 orbit numbers have $2^2 \cdot 7$ as part of their prime factorization. We also found that orbit numbers

containing a factor $2^2 \cdot 7$ are often succeeded by a number who also contain a factor $2^2 \cdot 7$, leading to sequences of successive orbit numbers containing a factor $2^2 \cdot 7$. Apparently $2^2 \cdot 7$ is to a certain extent a persistent factor. This can be understood as follows. When an orbit arrives at a number $n_k = 2^2 \cdot 7 \cdot r$, where $r > 1$ has not 2 or 7 as a divisor, then n_{k+1} also has $2^2 \cdot 7$ as a divisor:

$$\begin{aligned} n_{k+1} &= \sigma(n_k) - n_k = \sigma(2^2) \cdot \sigma(7) \cdot \sigma(r) - 2^2 \cdot 7 \cdot r & (3.21) \\ &= 7 \cdot 2^3 \cdot \sigma(r) - 2^2 \cdot 7 \cdot r = 2^2 \cdot 7 \cdot (2\sigma(r) - r) . \end{aligned}$$

Since $2\sigma(r) - r$ is odd, only the presence of 7 as a divisor of $(2\sigma(r) - r)$ may cause the next orbit number not containing $2^2 \cdot 7$ in its prime factorization and the sequence is broken.

There are more persistent factors. To derive them we write an orbit number n as

$$n = d \cdot r , \quad (3.22)$$

where the integer d is the persistent factor and the integer r is n/d with $\gcd(d, r) = 1$. For its successor we obtain

$$s(n) = \sigma(d) \cdot \sigma(r) - d \cdot r = d \cdot \left(\frac{\sigma(d)}{d} \cdot \sigma(r) - r \right) . \quad (3.23)$$

For d to be a persistent factor we can require $\sigma(d)/d$ to be integer. Now $\sigma(r)$ is odd only if r is a square. The probability for a number r to be a square is very small for large r . Therefore almost all $\sigma(r)$ will be even. For even $\sigma(r)$ it is sufficient to require $\sigma(d)/d$ to be half-integer. All together we require

$$\frac{\sigma(d)}{d} = \frac{m}{2} + 1 , \quad (3.24)$$

where m is a positive integer. Then

$$s(n) = d \cdot \left(\left(\frac{m}{2} + 1 \right) \cdot \sigma(r) - r \right) . \quad (3.25)$$

Since $\sigma(r) \geq r$ we have for $r > 1$

$$s(n) > \frac{m}{2} n . \quad (3.26)$$

In particular for $r = 1$ we have

$$s(d) = \frac{m}{2} d . \quad (3.27)$$

The multiplication factor μ is defined as the ratio of $s(n)$ and n :

$$s(n) = \mu n . \quad (3.28)$$

If $r = 1$ then

$$\mu = \frac{m}{2} \quad (3.29)$$

is the multiplication factor of a persistent factor. For instance, if d is a perfect number, then $\sigma(d) = 2d$ and $\mu = 1$. If d is a 3-perfect number, $\sigma(d) = 3d$, then $\mu = 2$. If $r > 1$ then $\mu > m/2$. Its value depends on r .

The requirement (3.24) leads to 14 persistent factors smaller than 10^6 , see next table.

d	μ
2	1/2
$6 = 2 \cdot 3$	1
$24 = 2^3 \cdot 3$	3/2
$28 = 2^2 \cdot 7$	1
$120 = 2^3 \cdot 3 \cdot 5$	2
$496 = 2^4 \cdot 31$	1
$672 = 2^5 \cdot 3 \cdot 7$	2
$4320 = 2^5 \cdot 3^3 \cdot 5$	5/2
$4680 = 2^3 \cdot 3^2 \cdot 5 \cdot 13$	5/2
$8128 = 2^6 \cdot 127$	1
$26\,208 = 2^5 \cdot 3^2 \cdot 7 \cdot 13$	5/2
$30\,240 = 2^5 \cdot 3^3 \cdot 5 \cdot 7$	3
$32\,760 = 2^3 \cdot 3^2 \cdot 5 \cdot 7 \cdot 13$	3
$523\,776 = 2^9 \cdot 3 \cdot 11 \cdot 31$	2

Notice that if 6 is a persistent factor, then also 2 is a persistent factor. The same holds for 120 and 24, for 30 240 and 4320, and for 32 760 and 4680. In these cases the largest one is taken as the persistent factor.

3.6 Drivers

Large d with relatively many prime factors are usually not very persistent. So, to select the d which are persistent and substantially present in orbits one needs a selection criterion. To this end d , which is even, is written as $d = 2^a v$, where v is odd. As a selection criterion one requires v to be a divisor of $2^{a+1} - 1$ and 2^{a-1} to be a divisor of $\sigma(v)$. Numbers $2^a v$ satisfying these two conditions are called *drivers* [3]. Let us obtain the drivers for the first ten a . This can be done by hand.

For $a = 1$ the conditions read $v|3$ and $1|\sigma(v)$. They are satisfied for $v = 1$ and $v = 3$.

For $v = 1$ the driver is 2 and for $v = 3$ the driver is 6.

For $a = 2$ the conditions read $v|7$ and $2|\sigma(v)$. They are satisfied for $v = 7$. The driver is 28.

For $a = 3$ the conditions read $v|15 = 3 \cdot 5$ and $4|\sigma(v)$. They are satisfied for $v = 3$ and $v = 15$.

For $v = 3$ the driver is 24 and for $v = 15$ the driver is 120.

For $a = 4$ the conditions read $v|31$ and $8|\sigma(v)$. They are satisfied for $v = 31$. The driver is 496.

For $a = 5$ the conditions read $v|63 = 3^2 \cdot 7$ and $16|\sigma(v)$. They are satisfied for $v = 21$.

The driver is 672.

For $a = 6$ the conditions read $v|127$ and $32|\sigma(v)$. They are satisfied for $v = 127$.

The driver is 8128.

For $a = 7$ the conditions read $v|255 = 3 \cdot 5 \cdot 17$ and $64|\sigma(v)$. No v satisfies both conditions.

For $a = 8$ the conditions read $v|511 = 7 \cdot 73$ and $128|\sigma(v)$. No v satisfies both conditions.

For $a = 9$ the conditions read $v|1023 = 3 \cdot 11 \cdot 31$ and $256|\sigma(v)$. They are satisfied for $v = 1023$.

The driver is 523 776.

For $a = 10$ the conditions read $v|2047 = 23 \cdot 89$ and $512|\sigma(v)$. No v satisfies both conditions.

It is proven that for $a > 10$ there is no v satisfying both conditions, except if $v = 2^{a+1} - 1$ is a Mersenne prime [3]. The first example of the exception is $a = 12$. Then the conditions $v|8191$ and $2048|\sigma(v)$ are satisfied for $v = 8191$ and the driver is the perfect number 33 550 336.

In conclusion, a driver is a perfect number or a member of $\{2, 24, 120, 672, 523\,776\}$.

It seems a bit strange that 523 776 has survived as a driver while 4320, 4680, 26 208, 30 240 and 32 760 have not. Alternatively, one could also use the selection criterion that a driver is a persistent factor smaller than 10 000, or that a persistent factor is smaller than 1000, or that a persistent factor is smaller than 10 000 and has not more than three different prime factors, or whatever seems suited.

Before we try to find a suitable selection criterion we will first investigate how frequent a persistent fraction occurs in lengthy orbits, its average multiplication factor and the average length of the sequence of successive orbit numbers containing the persistent factor. For instance, in the first 801 numbers of the orbit starting with 276 the persistent factors 2, 24 and 28 occurred 60, 26 and 255 times respectively. The mean multiplication factors are 0.664, 1.642 and 1.294 respectively. The mean sequence lengths are 30.00, 8.67 and 8.50 respectively. For the lengthy orbits starting with 276, 552, 564, 660, 966, 1074, 1134 and 1464 the frequencies of persistent factors 2, 6, 24, 28, 120, 496, 672, 4320, 4680 and 8128 are shown the next table. The second column is the investigated length of the orbit.

n_0	#	2	6	24	28	120	496	672	4320	4680	8128
276	801	60	0	26	255	0	0	0	0	0	0
552	729	30	0	9	433	0	0	0	0	0	0
564	1001	264	406	8	3	0	0	0	0	0	0
660	316	18	24	7	3	0	0	159	0	0	0
966	382	9	19	23	124	126	0	0	0	0	0
1074	1001	236	27	82	86	10	108	0	0	0	0
1134	751	225	102	30	0	32	0	0	0	0	0
1464	1640	446	189	20	129	6	186	3	0	0	0

For the same orbits the mean of the observed multiplication factors of persistent factors are shown the next table. The second row is the theoretical minimum of the multiplication factor.

n_0	2	6	24	28	120	496	672	4320	4680	8128
$[\mu]$	0.500	1.000	1.500	1.000	2.000	1.000	2.000	2.500	2.500	1.000
276	0.664	-	1.642	1.294	-	-	-	-	-	-
552	0.552	-	1.562	1.411	-	-	-	-	-	-
564	1.093	1.154	1.714	1.264	-	-	-	-	-	-
660	1.195	1.242	1.629	1.196	-	-	2.228	-	-	-
966	1.573	1.227	2.260	1.450	2.163	-	-	-	-	-
1074	0.644	1.157	1.628	1.378	2.185	1.431	-	-	-	-
1134	0.879	1.184	1.834	-	2.182	-	-	-	-	-
1464	0.706	1.182	1.588	1.427	2.057	1.486	2.408	-	-	-

For the same orbits the mean sequence lengths of persistent factors are shown the next table.

n_0	2	6	24	28	120	496	672	4320	4680	8128
276	30.00	-	8.67	8.50	-	-	-	-	-	-
552	10.00	-	3.00	11.39	-	-	-	-	-	-
564	13.89	22.56	4.00	3.00	-	-	-	-	-	-
660	2.57	6.00	2.33	3.00	-	-	11.75	-	-	-
966	4.50	9.50	2.30	13.78	15.75	-	-	-	-	-
1074	15.73	6.75	6.83	10.75	3.33	27.00	-	-	-	-
1134	14.06	8.50	3.00	-	6.40	-	-	-	-	-
1464	15.93	18.90	5.00	9.21	6.00	20.00	3.00	-	-	-

We see that persistent factors larger than 1000 do not occur in the 6620 investigated orbit numbers ranging from 4 through 99 digits. Hence, a practical selection criterion for driver is: a persistent factor below 1000. It selects as a driver: 2, 6, 24, 28, 120, 496 and 672.

3.7 Amicable and sociable numbers

If $s(n_0) = n_1 \neq n_0$ and $s(n_1) = n_0$, then (n_0, n_1) is a pair of amicable numbers. The first amicable pairs are $(220, 284)$, $(1184, 1210)$, $(2620, 2924)$, $(5020, 5564)$, $(6232, 6368)$, ... There are 586 amicable pairs with smallest member below 10^9 . The number of amicable pairs with smallest member smaller than or equal to k is plotted in the next figure for $k \leq 10^9$.

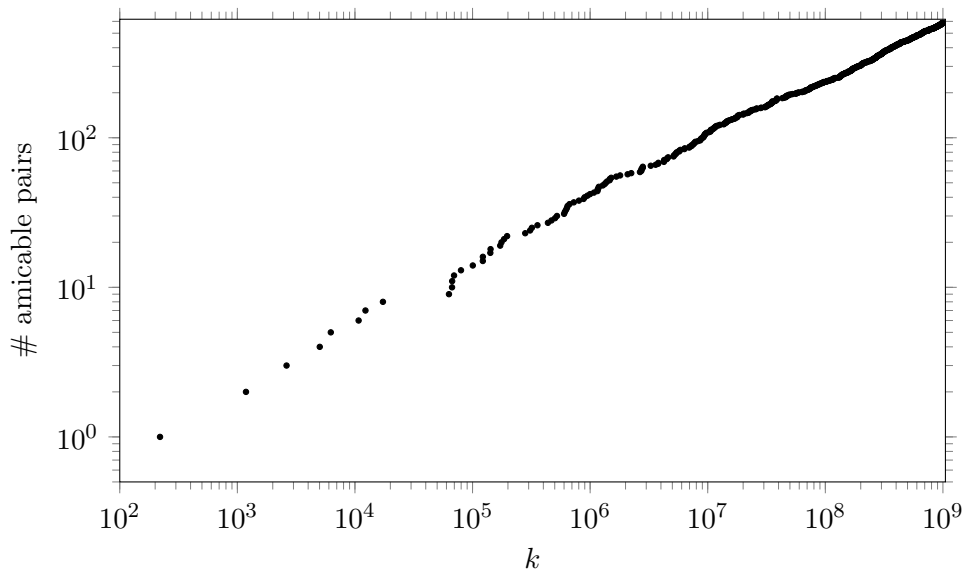

Figure 3.1: Number of amicable pairs with smallest member smaller than or equal to k .

It still is an open question whether or not there are infinitely many amicable pairs.

For amicable pairs below 10^9 we observe that both members have equal parity. Among the 586 amicable pairs below 10^9 there are 432 pairs with both members even and 154 pairs with both members odd. It is an open question if amicable pairs exist with one odd and one even member.

An amicable pair is considered *regular* if the non-common part of each member is square free. Thus if we write a pair (n_0, n_1) as (gN_0, gN_1) , where g is the greatest common divisor of n_0 and n_1 , $g = GCD(n_0, n_1)$, then the cycle is regular if N_0 and N_1 are both square free. A pair is *irregular* if it is not regular. For example, for the pair $(220, 284) = (2^2 \cdot 5 \cdot 11, 2^2 \cdot 71)$ the common factor is 2^2 and the non common parts are $(5 \cdot 11, 71)$. Since $N_0 = 5 \cdot 11$ and $N_1 = 71$ are both square free, the pair $(220, 284)$ is regular. As another example, for the pair $(1184, 1210) = (2^5 \cdot 37, 2 \cdot 5 \cdot 11^2)$ the common factor is 2^1 and the non common parts are $(2^4 \cdot 37, 5 \cdot 11^2)$. Since $N_0 = 2^4 \cdot 37$ and $N_1 = 5 \cdot 11^2$ are not both square free, the pair $(1184, 1210)$ is irregular. Of the 586 amicable pairs concerned above, 505 are regular and 81 are irregular. That is, approximately 86% of these 586 pairs are regular.

A pair of amicable numbers is in fact a period 2 cycle. One can also look for period m cycles. The set $(n_0, n_1, n_2, \dots, n_{m-1})$ is a period m cycle if $s^{(m)}(n_0) = n_0$. The cycle is elementary if no two members are equal. The elements of such sets are *sociable* numbers.

Below 10^9 there are no period 3 cycles.

Below 10^9 there are 14 elementary period 4 cycles:

- 1 (1 264 460, 1 547 860, 1 727 636, 1 305 184),
- 2 (2 115 324, 3 317 740, 3 649 556, 2 797 612),
- 3 (2 784 580, 3 265 940, 3 707 572, 3 370 604),
- 4 (4 938 136, 5 753 864, 5 504 056, 5 423 384),
- 5 (7 169 104, 7 538 660, 8 292 568, 7 520 432),
- 6 (18 048 976, 20 100 368, 18 914 992, 19 252 208),
- 7 (18 656 380, 20 522 060, 28 630 036, 24 289 964),
- 8 (28 158 165, 29 902 635, 30 853 845, 29 971 755),
- 9 (46 722 700, 56 833 172, 53 718 220, 59 090 084),
- 10 (81 128 632, 91 314 968, 96 389 032, 91 401 368),
- 11 (174 277 820, 205 718 020, 262 372 988, 210 967 684),
- 12 (209 524 210, 246 667 790, 231 439 570, 230 143 790),
- 13 (330 003 580, 363 003 980, 399 304 420, 440 004 764),
- 14 (498 215 416, 506 040 584, 583 014 136, 510 137 384).

We observe that all four members of a period 4 cycle have equal parity. Similar to what is done for amicable pairs, a period 4 cycle is considered *regular* if the non-common part of each member is square free. Thus if we write the members (n_0, n_1, n_2, n_3) of a period 4 cycle as (gN_0, gN_1, gN_2, gN_3) , where $g = GCD(n_0, n_1, n_2, n_3)$, then the cycle is regular if N_0, N_1, N_2 and N_3 are all square free. Among the 14 period 4 cycles given above the 1-th, 2-nd, 5-th and 9-th one are not regular. That is, approximately 71% of these 14 pairs are regular.

By considering also starting value larger than 10^9 one obtains a lot more amicable pairs and period 4 cycles. At the moment more than a billion amicable pairs and more than five thousand period 4 cycles are known. For other cycle lengths there are just a few cycles known now:

1 period 5 cycle: (12496, 14288, 15472, 14536, 14264),

5 period 6 cycles:

(21 548 919 483, 23 625 285 957, 24 825 443 643, 26 762 383 557, 25 958 284 443, 23 816 997 477),
 (90 632 826 380, 101 889 891 700, 127 527 369 100, 159 713 440 756, ..., 106 246 338 676),
 (1 771 417 411 016, 1 851 936 384 424, 2 118 923 133 656, 2 426 887 897 384, ..., 2 024 477 041 144),
 (3 524 434 872 392, 4 483 305 479 608, 4 017 343 956 392, 4 574 630 214 808, ..., 3 890 837 171 608),
 (4 773 123 705 616, 5 826 394 399 664, 5 574 013 457 296, 5 454 772 780 208, ..., 5 091 331 952 624),

4 period 8 cycles:

(1 095 447 416, 1 259 477 224, 1 156 962 296, 1 330 251 784, 1 221 976 136, ..., 1 213 138 984).
 (1 276 254 780, 2 299 401 444, 3 071 310 364, 2 303 482 780, 2 629 903 076, ..., 1 697 298 124),
 (7 914 374 573 864, 8 650 595 472 376, 10 411 746 556 424, 9 975 530 282 296, ..., 8 890 420 285 336),
 (138 344 559 911 415, 150 752 214 775 305, 156 933 404 745 975, ..., 168 479 018 493 705),

1 period 9 cycle:

(805 984 760, 1 268 997 640, 1 803 863 720, 2 308 845 400, 3 059 220 620, ..., 1 611 969 514)

and 1 period 28 cycle:

(14 316, 19 116, 31 704, 47 616, 83 328, 177 792, 295 488, 629 072, 589 786, 294 896, 358 336,
 418 904, 366 556, 274 924, 275 444, 243 760, 376 736, 381 028, 285 778, 152 990, 122 410, 97 946,
 48 976, 45 946, 22 976, 22 744, 19 916, 17 716).

Chapter 4

\mathcal{S} function

4.1 Introduction

By means of the sum-of-divisors function σ and a greatest common divisor we create the following iteration:

$$n_{k+1} = \frac{\sigma(n_k)}{\gcd(n_k, \sigma(n_k))}, \quad (4.1)$$

where $\gcd(n_k, \sigma(n_k))$ is the greatest common divisor of n_k and $\sigma(n_k)$. For brevity we will denote the iteration as

$$n_{k+1} = \mathcal{S}(n_k), \quad (4.2)$$

where the \mathcal{S} function is defined as

$$\mathcal{S}(n) = \frac{\sigma(n)}{\gcd(n, \sigma(n))}. \quad (4.3)$$

For instance, for $n = 6$ we obtain $\mathcal{S}(6) = \frac{\sigma(6)}{\gcd(6, \sigma(6))} = \frac{12}{\gcd(6, 12)} = \frac{12}{6} = 2$ and for $n = 7$ we obtain $\mathcal{S}(7) = \frac{\sigma(7)}{\gcd(7, \sigma(7))} = \frac{8}{\gcd(7, 8)} = \frac{8}{1} = 8$.

4.2 Cycles of the \mathcal{S} function

For $n = 1, 2, 3, 4, 5, 6, 7, 8, 9, \dots$ the corresponding \mathcal{S} values form the sequence 1, 3, 4, 7, 6, 2, 8, 15, 13, The latter is known as the sequence A017665 of the OEIS [2].

If we start with $n_0 = 1$ then $n_1 = 1$, $n_2 = 1$, and so on. That is, (1) is the trivial period 1 cycle or fixed point. We will denote it as c_0 . If we start with $n_0 = 2$ then $n_1 = 3$, $n_2 = 4$, $n_3 = 7$, $n_4 = 8$, $n_5 = 15$, $n_6 = 8$, etc. That is, (8, 15) is a period 2 cycle, which we will denote as c_1 . For starting values smaller than 66, the graph is shown in the next figure.

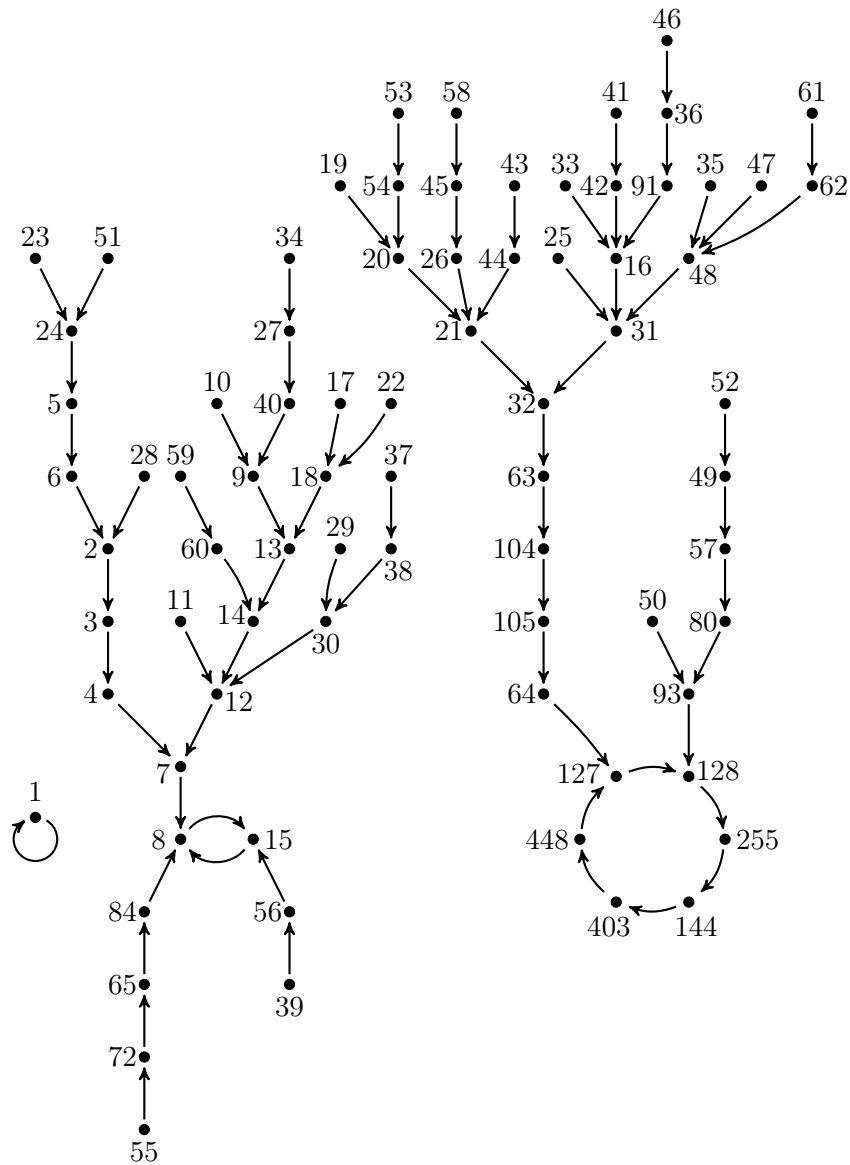

We see that for starting values smaller than 66 the iteration also shows a period 6 cycle.

For starting values $n_0 \leq 10^{10}$ the iteration $n_{k+1} = \mathcal{S}(n_k)$ contains

one fixed point: $c_0 = (1)$,

three period 2 cycles: $c_1 = (8, 15)$, $c_2 = (512, 1023)$, $c_3 = (29127, 47360)$ and

one period 6 cycle: $c_4 = (127, 128, 255, 144, 403, 448)$.

The smallest n_0 for which the orbit ends in c_4 is 16. The orbit is 16, 31, 32, 63, 104, 105, 64, 127, ... The smallest n_0 for which the orbit ends in c_2 is 81. The orbit is 81, 121, 133, 160, 189, 320, 381, 512, ... The smallest n_0 for which the orbit ends in c_3 is 22 521. The orbit is 22 521, 30 032, 29 109, 40 192, 40 369, 47 360, 29 127, ...

4.3 Statistics of cycle arrivals

For $n_0 \leq 10^8$ the fractions of starting numbers for which the orbit arrives in c_1 , c_2 , c_3 or c_4 are plotted in the next figure.

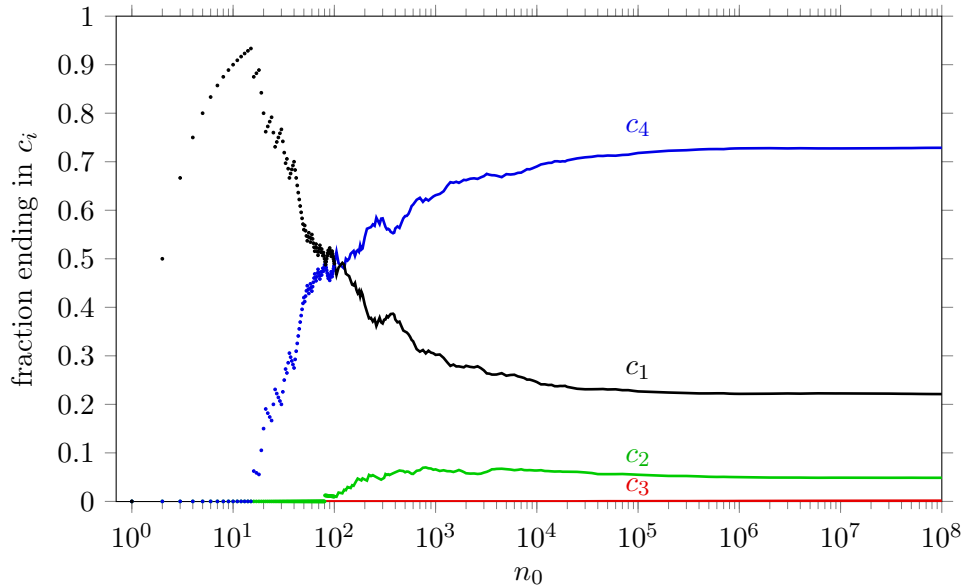

Figure 4.1: The fractions of starting numbers of which the orbit arrives in c_1 (black), c_2 (green), c_3 (red) or c_4 (blue).

Each fraction seems to approach a limit value for $n_0 \rightarrow \infty$.

For $n_0 \leq 10^8$ the fractions of starting numbers for which the orbit arrives in c_1 , c_2 , c_3 or c_4 are approximately 0.2211, 0.0487, 0.00147 and 0.7287 respectively.

For $n_0 \leq 10^8$ the fractions of starting numbers for which the orbit arrives in c_1 at 8, in c_1 at 15, in c_2 at 512, in c_2 at 1023, in c_3 at 29 127, in c_3 at 47 360, in c_4 at 127, in c_4 at 128, in c_4 at 255, in c_4 at 144, in c_4 at 403 or in c_4 at 448 are approximately 0.1985, 0.0226, 0.0408, 0.0079, 0.00070, 0.00078, 0.4749, 0.2284, 0.0089, 0.0040, 0.0091, 0.0034 respectively.

4.4 Statistics of untouchables

If we start with $n_0 = 2$ then $n_1 = 3$, $n_2 = 4$, $n_3 = 7$, $n_4 = 8$, $n_5 = 15$, $n_6 = 8$, $n_7 = 15$ and so on. From the orbit 2, 3, 4, 7, 8, 15, 8, ... we see that number 3 has 2 as predecessor and that 4 has 3 as predecessor and that 7 has 4 as predecessor and so on. However, 2 itself does not have a predecessor yet. So, if the starting numbers are confined to numbers of the set $\{1, 2, 3, 4\}$ then 2 is *untouchable*. If we start with $n_0 = 5$ then $n_1 = 6$, $n_2 = 2$, $n_3 = 3$, and so on, until it ends in the period 2 cycle (8, 15). So, for starting numbers $\{1, 2, 3, 4, 5\}$ the number 2 is no longer untouchable. Number 5 is the smallest starting number for which

2 is no longer untouchable. It turns out that 23 is the smallest starting number for which 5 is no longer untouchable. The smallest starting number for which a number n is no longer untouchable will be denoted as t_n .

If we start with numbers smaller than 10^3 , the first part of the list of t_n is as follows:

n	1	2	3	4	5	6	7	8	9	10	11	12	13	14	15	16	17	18	19	20	21	22	23	24	25	26	27	28	29	30
t_n	1	5	2	2	23	5	2	2	10	979	?	9	9	9	2	33	?	17	485	19	19	?	?	23	187	45	34	78	?	29

From $t_{10} = 979$ we see that 10 is an untouchable number if we confine to starting numbers smaller than 979. The question marks at position 11, 17, 22, 23, 29, ... show that for starting numbers smaller than 1000 the numbers 11, 17, 22, 23, 29, ... are untouchable. Question marks may disappear by taking larger starting numbers.

For starting numbers smaller than 10^6 the first part of the list of t_n is as follows:

n	6	7	8	9	10	11	12	13	14	15	16	17	18	19	20	21	22	23	24	25	26	27	28	29	30
t_n	5	2	2	10	979	33425	9	9	9	2	33	230153	17	485	19	19	1782	?	23	187	45	34	78	?	29

With respect to the previous situation the question marks for $n = 11, 17$ and 22 have disappeared.

By means of numerical inspection it is found that 23 becomes touchable for the first time if we start with $n_0 = 1\,404\,630\,689$. The orbit is $1\,404\,630\,689, 1\,907\,020\,800, 23, 24, 5, 6, 2, 3, 4, 7, 8, 15, 8, \dots$. A numerical inspection also learns that 29 is untouchable if the starting values are smaller than 10^{10} .

It raises the question whether a number 29 will become touchable if large enough starting numbers are used or are they truly untouchable in the sense that they stay untouchable even if infinitely large starting numbers are used.

If we only start with numbers from the set $\{1, 2, 3, 4\}$, then 2 is the only element of the set $\{1, 2, 3, 4\}$ which is untouchable. The ratio of untouchables and set length is $1/4$. If we only start with numbers from the set $\{1, 2, 3, 4, 5\}$, then 5 is the only element of the set $\{1, 2, 3, 4, 5\}$ which is untouchable. The ratio of untouchables and set length is $1/5$. As before,

we let u_n be the number of elements of the set $\{1, 2, 3, \dots, n\}$ which are untouchable if we only start with numbers from the set $\{1, 2, 3, \dots, n\}$. The ratio of untouchables and set length is u_n/n . For numbers up to 10^8 the ratio u_n/n is plotted against n in the next figure.

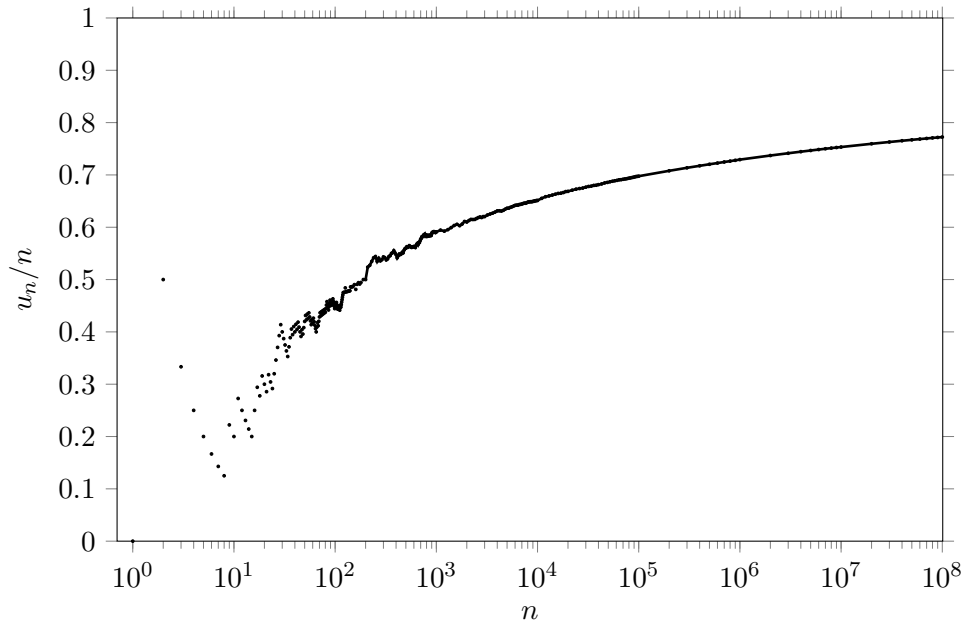

Figure 4.2: The ratio u_n/n , see text.

The question arises: what is the value of the ratio u_n/n in the limit $n \rightarrow \infty$?

4.5 Statistics of distances

Let us denote the number of steps required for a starting number n_0 to arrive at a periodic cycle as $D(n_0)$: the *distance* of n_0 . As a consequence, $D(n_0) = 0$ if n_0 is an element of one of the cycles c_0 through c_4 . For example, for the orbit 100, 217, 256, 511, 592, 589, 640, 153, 26, 21, 32, 63, 104, 105, 64, 127, ... we have $D(100) = 15$. For $n_0 \leq 10^8$ the largest distance is 41. It occurs for $n_0 = 59\,635\,801$: $D(59\,635\,801) = 41$. The distribution of distances is shown in the next figure.

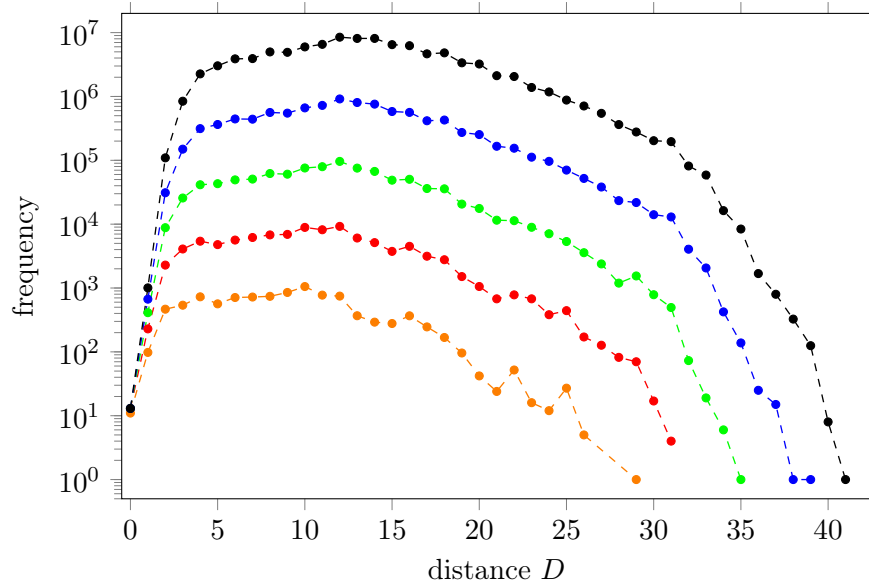

Figure 4.3: Distribution of distances for starting numbers smaller than or equal to: 10^4 (orange), 10^5 (red), 10^6 (green), 10^7 (blue), 10^8 (black).

The distribution of distances for numbers smaller than or equal to 10^8 is shown on a linear scale in the next figure.

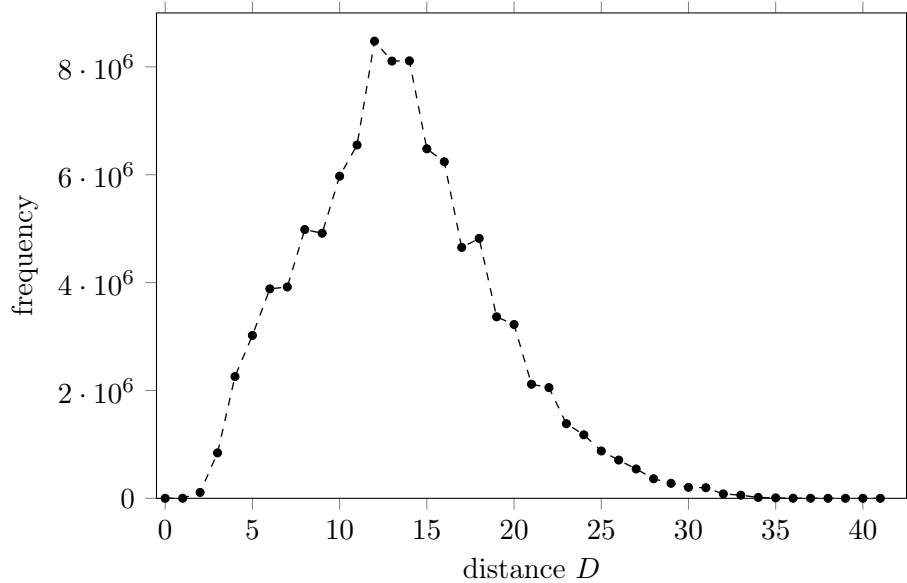

Figure 4.4: Distribution of distances for numbers smaller than or equal to 10^8 .

4.6 Even and odd orbit numbers

There are starting numbers for which successive orbit numbers repeatedly change from odd to even and from even to odd. For instance, for starting number 36 the orbit is 36, 91, 16, 31, 32, 63, 104, 105, 64, 127, ... That is, even, odd, even, odd, even, odd, even, odd, even, odd, ... Orbits with 2 or more successive even orbit numbers or with 2 or more successive odd orbit numbers do also occur. We start considering rows of even numbers.

For starting number 5 the orbit is 5, 6, 2, 3, 4, 7, 8, 15, 8, ... The orbit contains a row with 2 successive even orbit numbers. Moreover, 5 is the smallest starting numbers for which a row with 2 successive orbit numbers appears. The smallest starting numbers n_0 for which the orbit contains a row with k successive even numbers are tabulated below for $n_0 \leq 10^8$.

n_0	1	2	5	37	109	370	2061	10 982	24 466	59 341	262 534	3 759 878	13 126 565	43 439 846
k	0	1	2	3	4	5	6	7	8	9	10	11	12	13

The next figure shows a plot of the records of the length k of even rows.

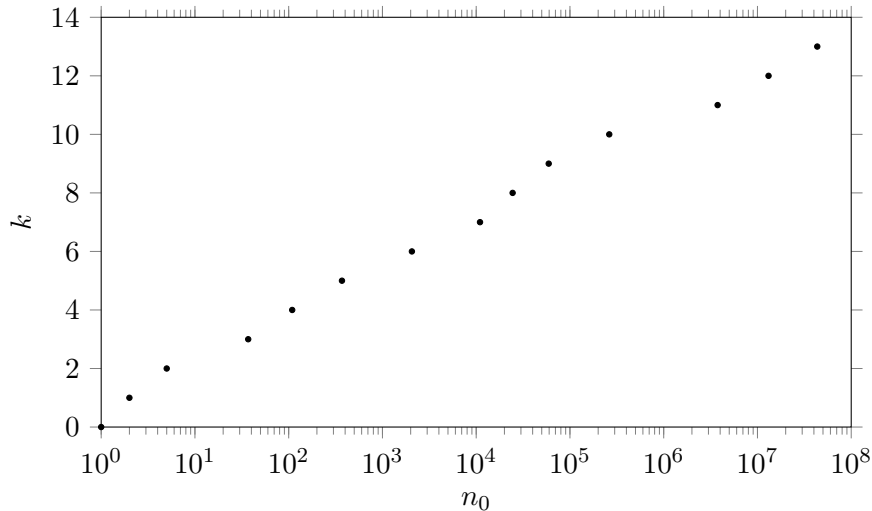

Figure 4.5: The length records of even rows.

For $n_0 \leq 10^8$ only starting number 43 439 846 leads to a row with 13 successive even orbit numbers. The orbit is 43 439 846, 32 579 886, 10 859 964, 2 111 662, 1 810 008, 71 110, 69 048, 2990, 3024, 620, 336, 62, 48, 31, 32, 63, 104, 105, 64, 127, ... We see the orbit descends from 43439846 to 31.

Next we will look for orbits with two or more successive odd orbit numbers in a row. Among

the odd numbers only the odd squares have an odd successor. The smallest starting number for which a row with 2 successive odd orbit numbers occur is 9. The orbit is 9, 13, 14, 12, 7, 8, 15, 8, ... The smallest starting number for which a row with 3 successive odd orbit numbers occur is 81. The orbit is 81, 121, 133, 160, 189, 320, 381, 512, 1023, 512, ... There are 128 unique rows of 3 successive odd numbers with the first element of the row smaller than 10^{16} . To get an impression the first six of them are shown below.

$$\begin{aligned} 81, 121, 133 &= 3^4, 11^2, 7 \cdot 19. \\ 480\,249, 361, 381 &= 3^4 \cdot 7^2 \cdot 11^2, 19^2, 3 \cdot 127. \\ 7\,935\,489, 3\,964\,081, 4\,381\,419 &= 3^4 \cdot 313^2, 11^2 \cdot 181^2, 3 \cdot 7 \cdot 19 \cdot 79 \cdot 139. \\ 9\,090\,225, 5\,697\,769, 1\,075\,419 &= 3^4 \cdot 5^2 \cdot 67^2, 7^2 \cdot 11^2 \cdot 31^2, 3^2 \cdot 19^2 \cdot 331. \\ 580\,858\,201, 106\,440\,489, 18\,129\,631 &= 7^2 \cdot 11^2 \cdot 313^2, 3^2 \cdot 19^2 \cdot 181^2, 13 \cdot 79 \cdot 127 \cdot 139. \\ 849\,431\,025, 7\,958\,041, 10\,357\,983 &= 3^2 \cdot 5^2 \cdot 29^2 \cdot 67^2, 7^2 \cdot 13^2 \cdot 31^2, 3^3 \cdot 19 \cdot 61 \cdot 331. \end{aligned}$$

The 128-th row with 3 successive odd numbers is

$$\begin{aligned} 9\,654\,983\,776\,089\,729, 14\,128\,780\,415\,929, 15\,008\,108\,788\,269 &= 98259777^2, 3758827^2, \\ 15008108788269 &= 3^6 \cdot 7^2 \cdot 11^2 \cdot 151^2 \cdot 313^2, 19^2 \cdot 181^2 \cdot 1093^2, 3^3 \cdot 79 \cdot 127 \cdot 139 \cdot 398581. \end{aligned}$$

The arithmetic of 9 654 983 776 089 729 is as follows:

$$\begin{aligned} \sigma(9654983776089729) &= \sigma(3^6 \cdot 7^2 \cdot 11^2 \cdot 151^2 \cdot 313^2) = \sigma(3^6) \cdot \sigma(7^2) \cdot \sigma(11^2) \cdot \sigma(151^2) \cdot \sigma(313^2) = \\ &= 1093 \cdot 57 \cdot 133 \cdot 22953 \cdot 98283 = 1093 \cdot (3 \cdot 19) \cdot (7 \cdot 19) \cdot (3 \cdot 7 \cdot 1093) \cdot (3 \cdot 181^2). \end{aligned}$$

Since $\sigma(9654983776089729)$ has the factors 3^3 and 7^2 in common with 9654983776089729, we have $\mathcal{S}(9654983776089729) = 19^2 \cdot 181^2 \cdot 1093^2 = 3758827^2$, which is an odd square. Therefore $\mathcal{S}(\mathcal{S}(965498377608972900))$ is odd, although not a square. As a result there are three successive odds in a row.

For 4 successive odds in a row the first three elements of the row have to be an odd square. The probability for a row with four successive odds is very small. To get a rough estimate of the small probability we consider the $5 \cdot 10^7$ odd squares smaller than 10^{16} . Among the $5 \cdot 10^7$ odd successors there are 148 odd squares. The probability for an odd square to have an odd square successor therefore is $\frac{148}{5 \cdot 10^7} \approx 3 \cdot 10^{-6}$. The probability for an odd square to have two odd square successors is $(3 \cdot 10^{-6})^2 \approx 10^{-11}$. So, among the $5 \cdot 10^8$ odd square starting values smaller than 10^{18} we expect approximately 0.005 rows with 4 successive odd numbers. No wonder a numerical inspection of odd squares smaller than 10^{18} did not deliver a row with 4 successive odd elements. For an expectation value of more than one row with 4 successive odd elements the search domain has to be extended to 10^{24} .

4.7 Records of maximums

Starting number 2 has orbit $\{2, 3, 4, 7, 8, 15, 8, \dots\}$. The largest value is the element 15 of cycle c_1 . We will call it the maximum M , thus $M(2) = 15$. Starting number 5 has orbit $\{5, 6, 2, 3, 4, 7, 8, 15, 8, \dots\}$. We thus have $M(5) = 15$. The maximum $M(5)$ does not supersede the previous maximum $M(2)$, so it is not a maximum record. We have to wait until starting number 16 for a maximum record: $M(16) = 448$. The next maximum record is $M(81) = 1023$. The first maximum record which is not an element of a cycle is $M(343) = 2160$. The maximum records are tabulated below for $n_0 \leq 10^9$.

#	n_0	M record	#	n_0	M record	#	n_0	M record
1	1	1	16	911 937	19 299 763	31	83 024 433	921 298 059
2	2	15	17	1 972 659	25 165 821	32	89 498 073	1 077 210 372
3	16	448	18	2 262 393	34 713 728	33	92 530 767	1 320 991 872
4	81	1023	19	2 949 429	46 467 543	34	119 340 783	1 487 137 239
5	343	2160	20	5 862 213	78 913 536	35	133 875 301	1 610 612 733
6	490	4218	21	6 482 116	89 522 176	36	191 411 613	2 864 709 632
7	935	4256	22	10 200 621	115 343 360	37	226 442 331	3 221 225 469
8	1029	22 528	23	13 475 300	155 493 536	38	232 943 763	4 294 967 295
9	5061	65 535	24	22 003 275	158 414 464	39	336 920 101	4 975 793 152
10	8661	73 216	25	23 110 311	268 435 455	40	547 264 135	5 141 692 416
11	18 049	602 547	26	31 810 161	274 148 352	41	551 895 033	6 214 123 520
12	39 981	1 048 575	27	32 098 437	292 563 381	42	663 592 629	6 341 787 648
13	100 261	1 432 640	28	35 006 209	621 974 144	43	676 473 985	6 214 123 520
14	194 913	4 194 303	29	51 856 928	671 088 640	44	749 816 677	6 979 321 843
15	630 436	8 567 136	30	63 370 587	797 516 013	45	786 780 633	17 179 869 183

The records of orbit maximums have been plotted against the starting numbers $n_0 \leq 10^9$ in the next figure.

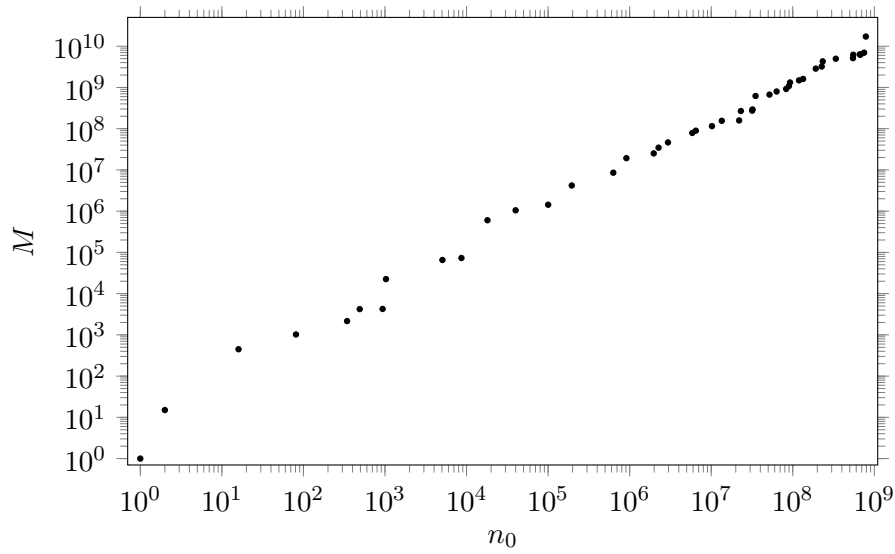

Figure 4.6: Records of orbit maximums M plotted against starting value n_0 .

As we saw, for starting value 2 the orbit is 2, 3, 4, 7, 8, 15, 8, ... Its maximum, 15, is a maximum record which occurs on the sixth position of the orbit. In the next figure the position of a maximum record in an orbit is plotted against the starting value of the orbit.

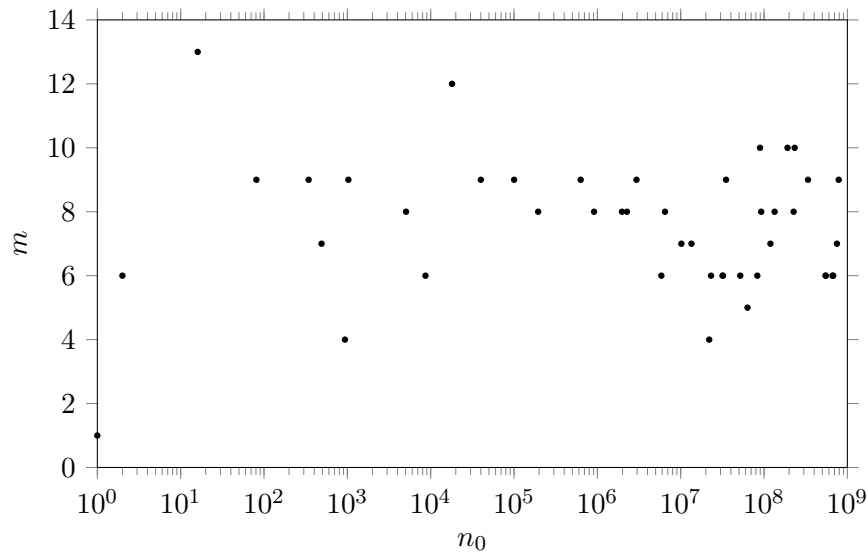

Figure 4.7: The m -th position of a maximum record in an orbit against n_0 .

The position of a maximum record in an orbit seems to be quite independent of the starting value of the orbit; the correlation is approximately -0.071 .

4.8 Records of distances

We saw earlier that the distance is 4 when one starts with number 2. That is, $D(2) = 4$. For increasing starting numbers we get $D(3) = 3$, $D(4) = 2$, $D(5) = 6$, $D(6) = 5$ and so on. We see the distance $D(5)$ does supersede $D(2)$. The next time a new distance record occurs is for number 16. The distance records D are tabulated below for $n_0 \leq 10^{10}$.

#	n_0	D record	#	n_0	D record	#	n_0	D record	#	n_0	D record
1	2	4	9	315	16	17	9597	29	25	4 934 601	37
2	5	6	10	328	17	18	10 964	30	26	7 378 869	39
3	16	7	11	453	18	19	41 763	31	27	47 424 794	40
4	19	8	12	977	19	20	129 603	32	28	59 635 801	41
5	36	9	13	1029	22	21	154 081	33	29	409 271 426	42
6	46	10	14	1171	24	22	582 928	34	30	995 329 569	43
7	97	14	15	1954	25	23	728 659	35	31	1 775 850 573	45
8	100	15	16	8125	26	24	3 451 988	36	32	2 029 543 507	47

The records of distances D are plotted against starting numbers n_0 in the next figure.

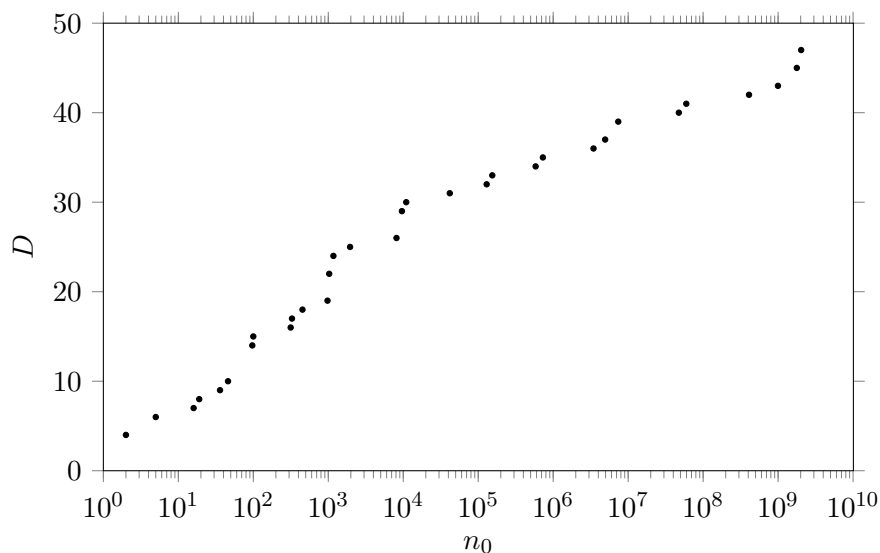

Figure 4.8: The records of distances D plotted against starting value n_0 .

For $n_0 \leq 10^8$ a simultaneous orbit maximum record and distance record occurs for $n_0 = 2, 16, 100$ and 1029 .

4.9 Questions

The iteration with the \mathcal{S} function does raise some questions:

Question 1: Are (1) , $(8, 15)$ $(127, 128, 255, 144, 403, 448)$, $(512, 1023)$ and $(29\ 127, 47\ 360)$ the only cycles?

Question 2: Does there exist an untouchable number?

Question 3: Is the smallest starting number for which an orbit contains a triple of successive odds equal to the first number of the triple?

Question 4: Does there exist a row with 4 or more successive odd numbers in a row?

Chapter 5

Collatz problem

5.1 Introduction

The Collatz problem or $3n + 1$ problem is based on the iteration

$$n_{k+1} = \begin{cases} \frac{3n_k + 1}{2} & \text{if } n_k \equiv 1 \pmod{2} \\ \frac{n_k}{2} & \text{if } n_k \equiv 0 \pmod{2} \end{cases} \quad (5.1)$$

where n_k is a positive integer. If we start with $n_0 = 1$ then the orbit is 1, 2, 1, 2, 1, 2, ... That is (1, 2) is a period 2 cycle. We will denote it as c_1 . For starting number 3 the orbit is 3, 5, 8, 4, 2, 1, ... For starting number 7 the orbit is 7, 11, 17, 26, 13, 20, 10, 5, 8, 4, 2, 1, ... We see that for starting numbers 3 and 7 the orbits arrive at c_1 . It has been verified by computer that for starting values up to almost 10^{21} the orbit arrives at the cycle c_1 .

5.2 Statistics of untouchables

For the Collatz iteration we will keep track of the smallest starting number t_n for which a number n is no longer untouchable.

The numbers t_1 through t_{100} are shown below.

1, 1, 6, 3, 3, 12, 9, 3, 18, 7, 7, 24, 7, 9, 30, 21, 7, 36, 25, 7, 42, 19, 15, 48, 33, 7, 54, 37, 19, 60, 27, 21, 66, 45, 15, 72, 43, 25, 78, 15, 27, 84, 57, 19, 90, 27, 27, 96, 43, 33, 102, 69, 15, 108, 73, 37, 114, 51, 39, 120, 27, 27, 126, 75, 43, 132, 39, 45, 138, 93, 27, 144, 97, 43, 150, 39, 51, 156, 105, 15, 162, 109, 55, 168, 75, 57, 174, 117, 39, 180, 27, 27, 186, 55, 63, 192, 129, 43, 198, 133. Since the third number is 6 we see that 3 is untouchable if we start with numbers smaller than 6. Similarly, 6 is untouchable if the starting numbers are confined to numbers smaller than 12 and 7 is untouchable if the starting numbers are confined to numbers smaller than 9, etc.

Since every number has at least one predecessor (the numbers 2, 5, 8, 11, ..., $3k - 1$, ... have two predecessors) there will on the long run be no untouchables. However, if we confine to a limited set of starting numbers, then there will be untouchables. For instance, the list above of t_1 through t_{100} contains 22 numbers larger than 100. This implies that if we only start with numbers from the set $\{1, 2, \dots, 99, 100\}$, then 22 numbers would be untouchable: $u_{100} = 22$. The ratio of untouchables and set length is $22/100 = 0.22$. For larger sets the ratio slightly changes. For numbers up to 10^5 the ratio u_n/n is plotted against n in the next figure.

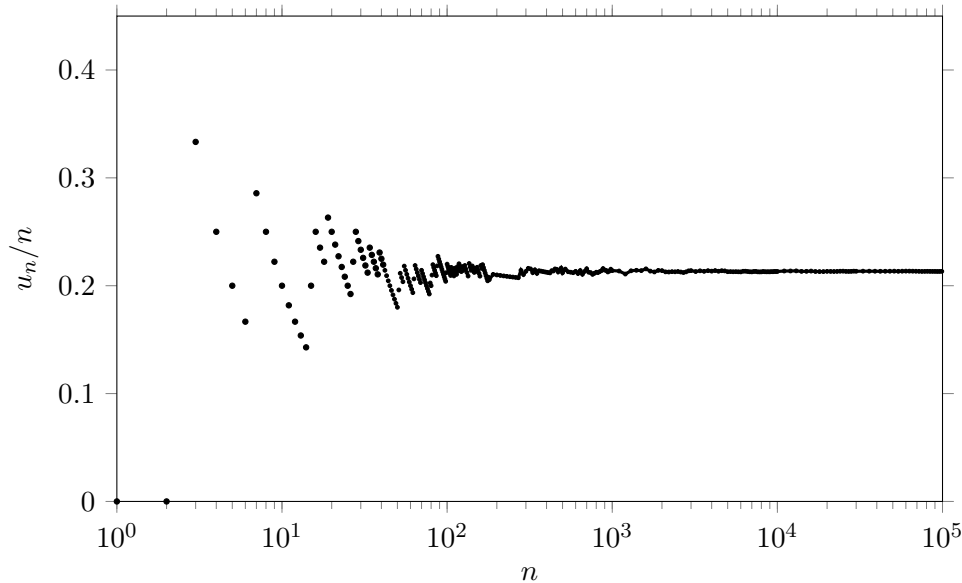

Figure 5.1: The ratio u_n/n against set length n .

The curve strongly suggest a limit value for the ratio u_n/n . We obtained

$$\lim_{n \rightarrow \infty} \frac{u(n)}{n} \approx 0.213. \quad (5.2)$$

5.3 Statistics of distances

As before we denote the number of steps required for a starting number n_0 to arrive at the periodic cycle (1, 2) as the distance $D(n)$. The distance $D(n_0) = 0$ if n_0 is an element of the cycle c_1 . Thus $D(1) = 0$ and $D(2) = 0$. For $n_0 \leq 10^8$ the largest distance is 591. It occurs for $n_0 = 63\,728\,127$: $D(63\,728\,127) = 591$. The distribution of distances is shown in the next figure.

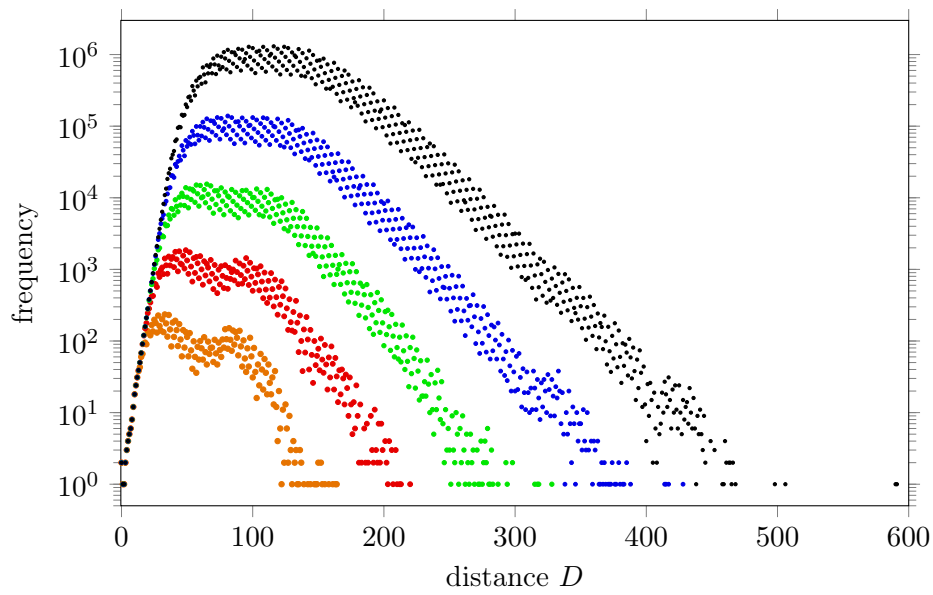

Figure 5.2: Distribution of distances for starting numbers smaller than or equal to: 10^4 (orange), 10^5 (red), 10^6 (green), 10^7 (blue), 10^8 (black).

The distribution of distances for numbers smaller than or equal to 10^8 is shown on a linear scale in the next figure.

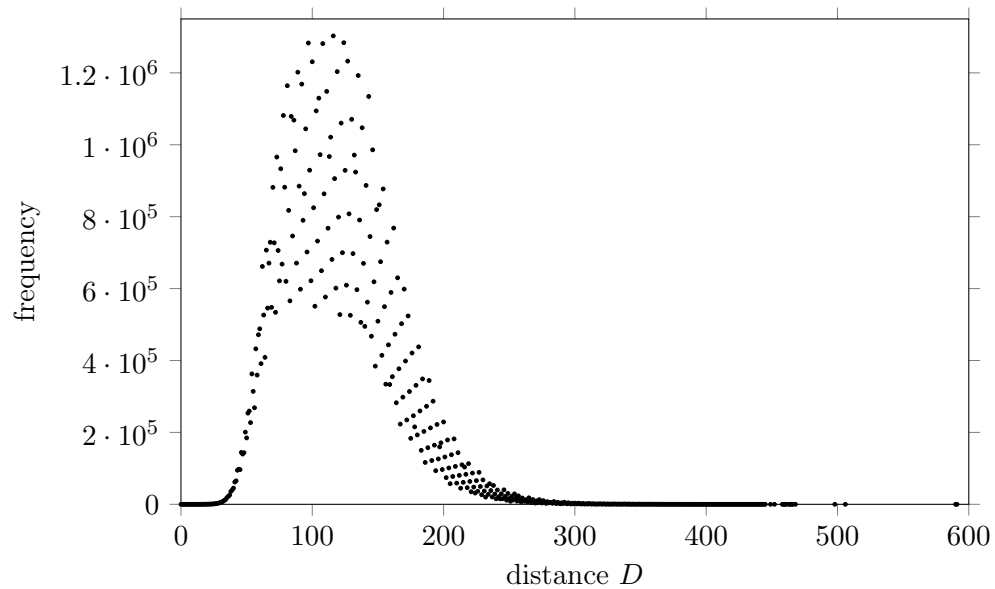

Figure 5.3: Distribution of distances for numbers smaller than or equal to 10^8 .

5.4 Even and odd orbit numbers

When an odd number of an orbit iterates to an even number $2^a b$ with b odd, there will be a successive even numbers in a row. Rows with successive odd numbers do also occur. We will start considering rows of even numbers.

For starting number 3 the orbit 3, 5, 8, 4, 2, 1, ... contains a row with three successive even numbers. Moreover, 3 is the smallest starting number for which a row with three successive even orbit numbers appears. The smallest starting numbers n_0 for which the orbit contains a row with at least k successive even numbers are tabulated below for $n_0 \leq 10^8$.

n_0	1	3	3	15	21	64	75	151	151	1024	1365	4096	5461	7407	14563	65536	87381	184111
k	1	2	3	4	5	6	7	8	9	10	11	12	13	14	15	16	17	18

n_0	184111	932067	932067	4194304	5592405	13256071	13256071	26512143	26512143
k	19	20	21	22	23	24	25	26	27

For $k = 6, 10, 12, 16$ and 22 there holds precisely $n_0 = 2^k$. The next figure shows a plot of the length records of even rows.

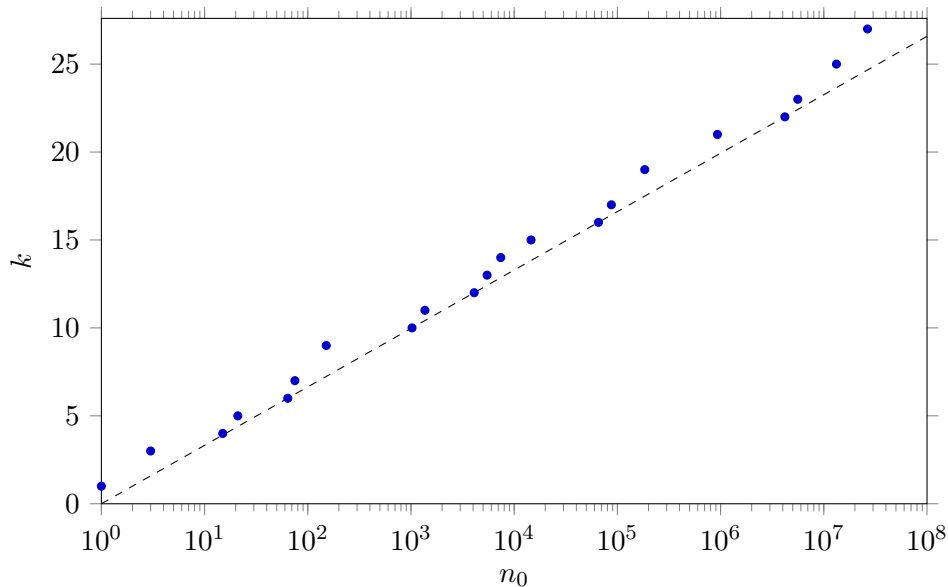

Figure 5.4: Records of length k of even rows against starting value n_0 of an orbit. The dashed curve is the function $n_0 = 2^k$.

The smallest starting number with a row with 27 successive even orbit numbers is 26 512 143. The orbit is 26 512 143, 39 768 215, 59 652 323, 89 478 485, 134 217 728, 67 108 864, 33 554 432, 16 777 216, 8 388 608, 4 194 304, 2 097 152, 1 048 576, 524 288, 262 144, 131 072, 65 536, 32 768, 16 384, 8192, 4096, 2048, 1024, 512, 256, 128, 64, 32, 16, 8, 4, 2, ... Since $134\,217\,728 = 2^{27}$ the row descends in 26 steps from 2^{27} to 2.

Next we will look for orbits with two or more successive odd orbit numbers in a row. The smallest starting numbers n for which the orbit contains a row with at least k successive odd numbers are tabulated below for $n_0 \leq 10^8$.

n_0	1	3	7	15	27	27	127	255	511	1023	1819	4095	4255	16383	32767	65535	77671
k	1	2	3	4	5	6	7	8	9	10	11	12	13	14	15	16	17

n_0	262143	459759	1048575	2097151	4194303	7456539	16777215	33554431	67108863
k	18	19	20	21	22	23	24	25	26

The records do satisfy $n_0 = 2^k - 1$, except for $n_0 = 27, 1819, 4255, 77\,671, 459\,759$ and $7\,456\,539$. The next figure shows a plot of the length records of odd rows.

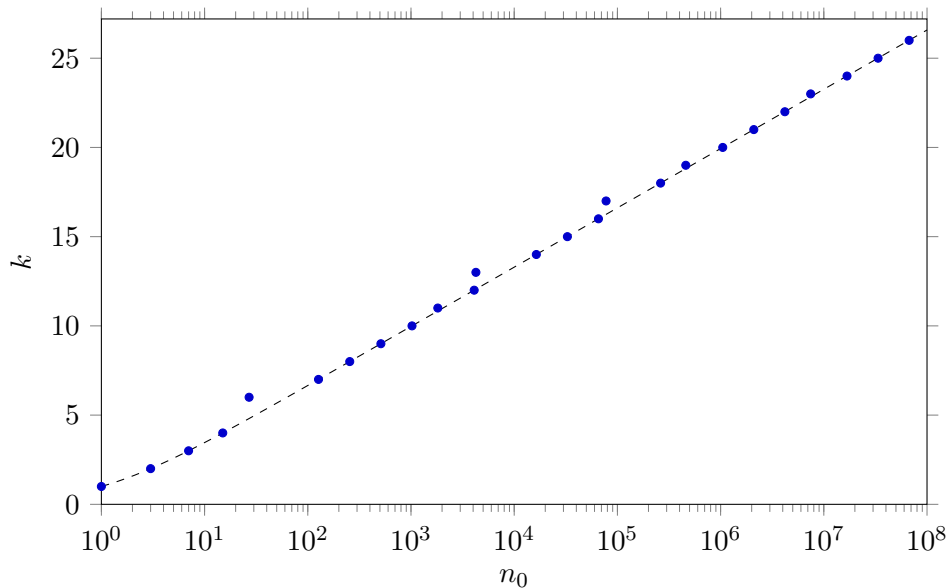

Figure 5.5: Records of length k of odd rows against starting value n_0 of an orbit. The dashed curve is the function $n_0 = 2^k - 1$

For starting numbers n_0 which do satisfy the relation $n_0 = 2^k - 1$, the next number is $n_1 = (3(2^k - 1) + 1)/2 = (3 \cdot 2^k - 2)/2 = 3 \cdot 2^{k-1} - 1$. After two steps we have $n_2 = 3^2 \cdot 2^{k-2} - 1$. Repetition of the arithmetic leads to $n_m = 3^m \cdot 2^{k-m} - 1$. After k steps we have $n_k = 3^k - 1$, which is even. Hence, starting with $n_0 = 2^k - 1$ we obtain an orbit with a row of k odd numbers.

5.5 Records of maximums

Starting number 3 has orbit 3, 5, 8, 4, 2, 1, 2, ... Since the orbit never leaves the $c_1 = (1, 2)$ cycle, the maximum value of the orbit is 8. We will call it the maximum M , thus $M(3) = 8$. Starting number 7 we have the orbit 7, 11, 17, 26, 13, 20, 10, 5, 8, 4, 2, 1, 2, ... That is, $M(7) = 26$, which is a new maximum record. Continuing the search we find the next maximum record for $n_0 = 15$: $M(15) = 80$. The maximum records are tabulated below for $n_0 \leq 10^8$.

#	n_0	M record	#	n_0	M record	#	n_0	M record
1	1	2	15	26 623	53 179 010	29	1 988 859	78 457 189 112
2	3	8	16	31 911	60 506 432	30	2 643 183	95 229 909 242
3	7	26	17	60 975	296 639 576	31	2 684 647	176 308 906 472
4	15	80	18	77 671	785 412 368	32	3 041 127	311 358 950 810
5	27	4616	19	113 383	1 241 055 674	33	3 873 535	429 277 584 788
6	255	6560	20	138 367	1 399 161 680	34	4 637 979	659 401 147 466
7	447	19 682	21	159 487	8 601 188 876	35	5 656 191	1 206 246 808 304
8	639	20 762	22	270 271	12 324 038 948	36	6 416 623	2 399 998 472 684
9	703	125 252	23	665 215	26 241 642 656	37	6 631 675	30 171 305 459 816
10	1819	638 468	24	704 511	28 495 741 760	38	19 638 399	153 148 462 601 876
11	4255	3 405 068	25	1 042 431	45 119 577 824	39	38 595 583	237 318 849 425 546
12	4591	4 076 810	26	1 212 415	69 823 368 404	40	80 049 391	1 092 571 914 585 050
13	9663	13 557 212	27	1 441 407	75 814 787 186			
14	20 895	25 071 632	28	1 875 711	77 952 174 848			

The records of orbit maximums have been plotted against starting numbers $n_0 \leq 10^8$ in the next figure.

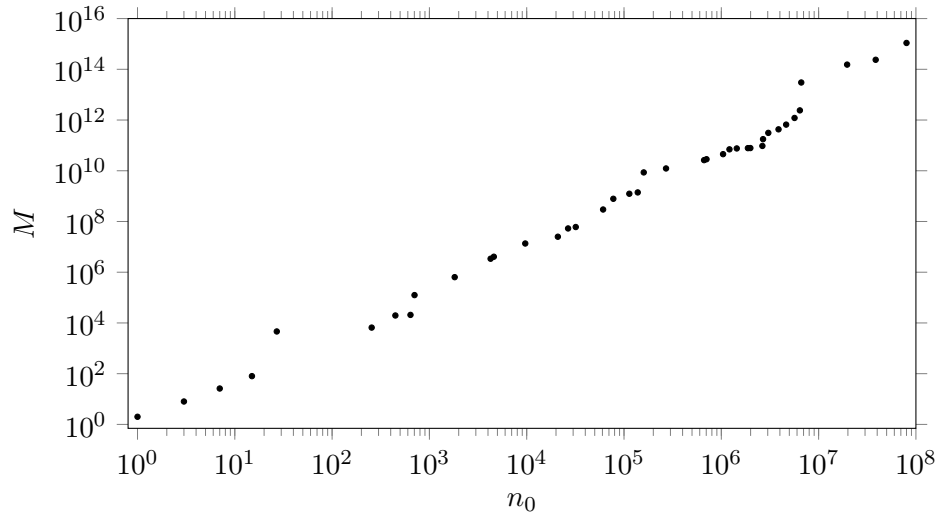

Figure 5.6: The records of orbit maximums M against starting value n .

For $n_0 \leq 10^8$ a simultaneous odd row length record and orbit maximum record occurs for $n = 1, 3, 7, 15, 255, 1819, 4255, 77\,671$.

5.6 Records of distances

For starting numbers $n_0 > 2$ the distances are $D(3) = 4$, $D(4) = 1$, $D(5) = 3$, $D(6) = 5$ and so on. We see the distance $D(6)$ does supersede $D(3)$. The next time a new distance record occurs is for starting number 7. The distance records are tabulated below for $n_0 \leq 10^9$.

#	n_0	D record	#	n_0	D record	#	n_0	D record	#	n_0	D record
1	3	4	9	73	72	17	703	107	25	10 971	168
2	6	5	10	97	74	18	871	112	26	13 255	173
3	7	10	11	129	76	19	1161	114	27	17 647	175
4	9	12	12	171	78	20	2223	115	28	23 529	177
5	18	13	13	231	80	21	2463	131	29	26 623	193
6	25	15	14	313	82	22	2919	136	30	34 239	195
7	27	69	15	327	90	23	3711	149	31	35 655	203
8	54	70	16	649	91	24	6171	164	32	52 527	213

#	n_0	D rec.	#	n_0	D rec.	#	n_0	D rec.	#	n	D rec.
33	77 031	220	41	626 331	318	49	3 732 423	373	57	36 791 535	465
34	106 239	222	42	837 799	328	50	5 649 499	383	58	63 728 127	591
35	142 587	235	43	1 117 065	330	51	6 649 279	415	59	127 456 254	592
36	156 159	240	44	1 501 353	332	52	8 400 511	428	60	169 941 673	594
37	216 367	242	45	1 723 519	348	53	11 200 681	430	61	226 588 897	596
38	230 631	277	46	2 298 025	350	54	14 934 241	432	62	268 549 803	601
39	410 011	281	47	3 064 033	352	55	15 733 191	440	63	537 099 606	602
40	511 935	294	48	3 542 887	365	56	31 466 383	441	64	670 617 279	615

The records of distances are plotted against the starting numbers for $n_0 \leq 10^{10}$ in the next figure.

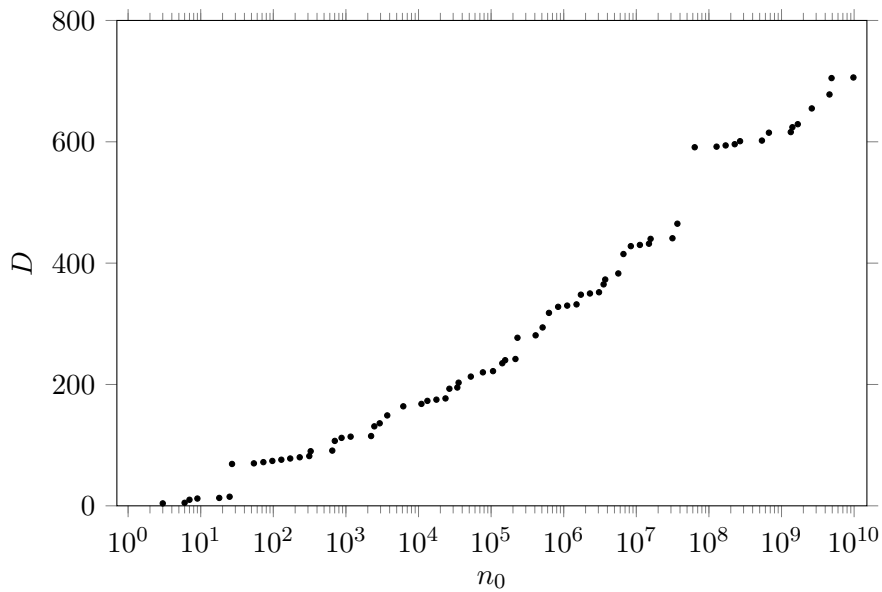

Figure 5.7: The records of distances D against starting value n_0 .

For $n_0 \leq 10^8$ both an orbit maximum record and a distance record occurs for $n = 3, 7, 27, 703$ and $26\,623$.

5.7 Rows of equal distance

Inspection tells there are many pairs $\{n, n+1\}$ which end at the cycle c_1 after the same amount of steps. The first pair is the trivial pair $(1, 2)$ which both have distance 0. The next pair is $(12, 13)$. Although the orbits are different, $12, 6, 3, 5, 8, 4, \dots$ and $13, 20, 10, 5, 8, 4, \dots$, the distance is 6 in both cases. In general pairs of the type $(8k+12, 8k+13)$ have the same distance since $8k+12 \rightarrow 4k+6 \rightarrow 2k+3 \rightarrow 3k+5$ and $8k+13 \rightarrow 12k+20 \rightarrow 6k+10 \rightarrow 3k+5$. The second pair is $(14, 15)$. Despite the different orbits, $7, 11, 17, 26, 13, 20, \dots$ and $15, 23, 35, 53, 80, 40, 20, \dots$, the distance is 11 in both cases. In general pairs of the type $(64k+14, 64k+15)$ have the same distance since

$$64k+14 \rightarrow 32k+7 \rightarrow 48k+11 \rightarrow 72k+17 \rightarrow 108k+26 \rightarrow 54k+13 \rightarrow 81k+20 \text{ and } 64k+15 \rightarrow 96k+23 \rightarrow 144k+35 \rightarrow 216k+53 \rightarrow 324k+80 \rightarrow 162k+40 \rightarrow 81k+20.$$

The next pair is $(18, 19)$ which has distance 13. Thereafter follows the pairs $(20, 21)$ with distance 5 and $(22, 23)$ with distance 10. Then we meet a triple $(28, 29, 30)$ for which all three members have distance 12. The part $(28, 29)$ is a pair of the type $(8k+12, 8k+13)$ and $(28, 30)$ is the double of the pair $(14, 15)$. The next triple is $(36, 37, 38)$ with distance 14. The first row with 4 members is $(314, 315, 316, 317)$ with distance 25. For equal distance rows $(r_1, r_2, \dots, r_\lambda)$ with row length λ , the first element r_1 and the distance D are tabulated below for $r_1 \leq 10^7$.

λ	r_1	D	λ	r_1	D	λ	r_1	D	λ	r_1	D	λ	r_1	D
1	1	0	10	4722	40	19	159 116	53	28	530 052	69	37	8 151 894	149
2	12	6	11	6576	88	20	79 592	52	29	331 778	62	38	3 705 089	78
3	28	12	12	11696	92	21	57 857	107	30	524 289	69	39	2 754 368	130
4	314	25	13	3982	35	22	212 160	55	31	1 088 129	135	40	596 310	66
5	98	17	14	2987	33	23	352 258	70	32	913 319	130	41	2 886 352	138
6	386	76	15	17 548	91	24	221 185	63	33	2 065 786	128	42	4 896 680	134
7	943	25	16	36 208	30	25	57 346	53	34	1 541 308	126	43	3 350 448	78
8	1494	32	17	7083	39	26	294 913	65	35	1 032 875	127	44	3 848 468	140
9	1680	29	18	59 692	50	27	252 548	117	36	1 264 924	86	45		

For $n_0 \leq 10^7$ we have tabulated below the number rows with row length λ whose members have the same distance.

λ	1	2	3	4	5	6	7	8	9	10
# rows	2 787 389	1 098 440	576 687	210 458	138 891	107 824	47 172	25 150	9850	9276

λ	11	12	13	14	15	16	17	18	19	20	21	22	23	24	25
# rows	7764	4619	3143	2529	3772	1430	1255	360	475	499	299	271	266	179	173

λ	26	27	28	29	30	31	32	33	34	35	36	37	38	39	40	41	42	43	44	45
# rows	179	75	57	46	87	53	29	12	17	18	8	2	5	11	7	4	3	5	4	0

For row lengths $\lambda = 1$ through 44, the cumulative number of rows with length λ are plotted against n_0 for $n_0 \leq 10^7$, see next figure.

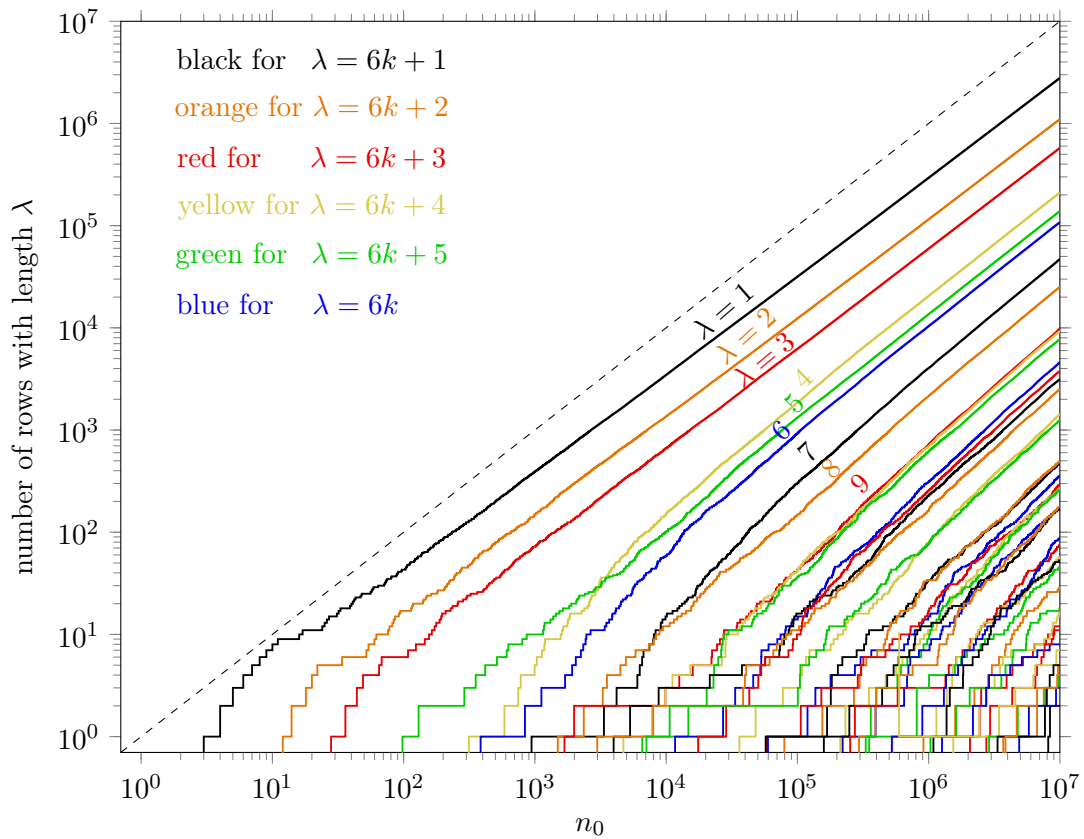

Figure 5.8: The number of same distance rows with length λ against n_0 for the Collatz iteration. The diagonal (dashed line) is drawn for comparison.

5.8 Question

For the Collatz iteration it is still an open question if every orbit ends in the $(1, 2)$ cycle.

Chapter 6

Negative Collatz

6.1 Introduction

The Collatz iteration or $3n + 1$ iteration for negative n is identical to an iteration based on $3n - 1$ for positive n . In this chapter we will consider sequences of integers generated by the discrete iteration

$$n_{k+1} = \begin{cases} \frac{3n_k - 1}{2} & \text{if } n_k \equiv 1 \pmod{2} \\ \frac{n_k}{2} & \text{if } n_k \equiv 0 \pmod{2} \end{cases} \quad (6.1)$$

where n_k is a positive integer. For the negative Collatz iteration we have

one fixed point: (1),

one period 3 cycle: (5, 7, 10) and

one period 11 cycle: (17, 25, 37, 55, 82, 41, 61, 91, 136, 68, 34).

It is not known whether another cycle does exist. It also is not known whether sequences always end in a cycle for every starting number.

6.2 Statistics of cycle arrivals

For starting numbers $n_0 \leq 10^7$ the fractions of numbers of which the sequences end in c_1 , c_2 and c_3 are plotted in the next figure.

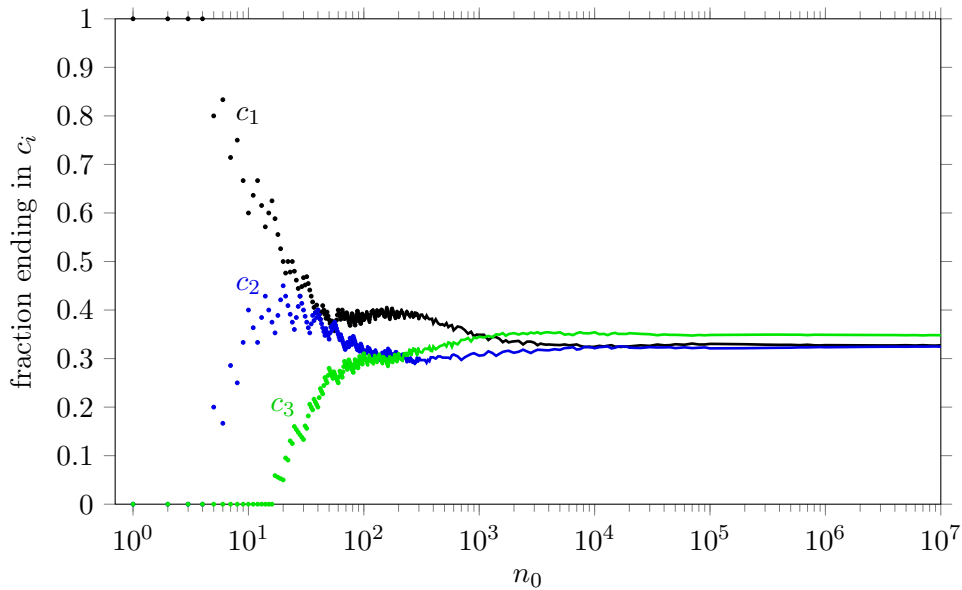

Figure 6.1: The fractions of numbers of which the sequences end in c_1 (black), c_2 (blue) and c_3 (green).

For $n_0 \leq 10^8$ the fractions of numbers for which the orbit arrives in c_1 , c_2 and c_3 are approximately 0.327, 0.324 and 0.348 respectively.

For $n_0 \leq 10^7$ the fraction of numbers for which the orbit arrives in c_1 at (1), in c_2 at (5), in c_2 at (7), in c_2 at (10), in c_3 at (17), in c_3 at (25), in c_3 at (37), in c_3 at (55), in c_3 at (82), in c_3 at (41), in c_3 at (61), in c_3 at (91), in c_3 at (136), in c_3 at (68) and in c_3 at (34) are approximately 0.327, 0, 0.268, 0.056, 0, 0.055, 0.035, 0.0055, 0.0031, 0, 0.196, 0.0057, 0.0021, 0 and 0.0457 respectively.

6.3 Statistics of untouchables

For each number n we will keep track of the smallest starting number t_n for which a number is no longer untouchable. If we start with numbers smaller than or equal to 100, the first 100 elements of the list of t_n is as follows:

1, 3, 6, 3, 5, 12, 5, 11, 18, 5, 15, 24, 9, 9, 30, 11, 17, 36, 9, 27, 42, 15, 21, 48, 17, 35, 54, 9, 39, 60, 21, 29, 66, 17, 47, 72, 17, 51, 78, 27, 17, 84, 29, 53, 90, 21, 63, 96, 33, 45, ?, 35, 57, ?, 17, 75, ?, 39, 53, ?, 17, 83, ?, 29, 87, ?, 45, 17, ?, 47, 57, ?, 33, 99, ?, 51, 69, ?, 53, ?, ?, 17, ?, ?, 57, 65, ?, 53, ?, ?, 17, ?, ?, 63, 57, ?, 65, ?, ?, 45.

We see, for instance, that $t_6 = 12$. It means that 6 is untouchable if we restrict to starting numbers smaller than 12. The 22 question marks show the numbers which are untouchable if we start with numbers smaller than or equal to 100. They become touchable if we start with numbers smaller than or equal to 200. Then there are 44 untouchables in the first 200

elements of the list of t_n . To be specific, the 44 untouchables are all in the last 100 elements of the list t_1 through t_{200} . They become touchable if we start with numbers smaller than or equal to 400. Then new untouchables will show up in the last 200 elements of the list of t_1 through t_{400} , and so on.

As before we let u_n be the number of untouchables if we start with positive integers smaller than n . For $n = 100$ we have $u_{100} = 22$ and the ratio of untouchables and starting numbers is 0.22. For $n = 200$ we have $u_{200} = 44$ and the ratio of untouchables and starting numbers is 0.22. For $n = 1000$ we have $u_{1000} = 214$ and the ratio of untouchables and starting numbers is 0.214. For numbers up to 10^5 the ratio u_n/n is plotted against n in the next figure.

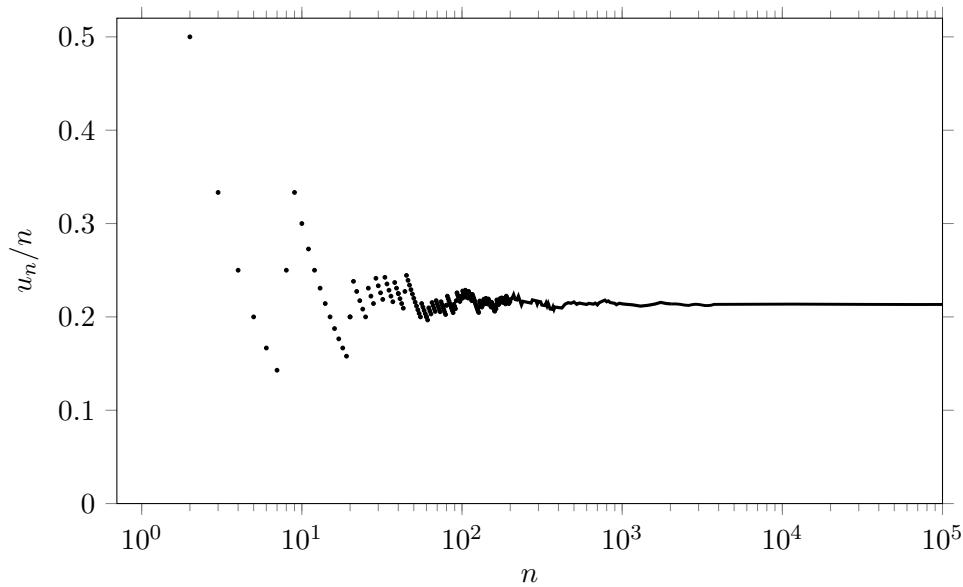

Figure 6.2: The ratio u_n/n against starting value n .

The curve strongly suggest a limit value for the ratio u_n/n . We obtained

$$\lim_{n \rightarrow \infty} \frac{u(n)}{n} \approx 0.213. \quad (6.2)$$

It seems to be the same value as for the positive Collatz iteration.

6.4 Statistics of distances

As before, the number of steps required for a starting number n to arrive at a periodic cycle is the distance $D(n)$. Thus $D(1) = 0$, $D(2) = 1$, $D(3) = 3$ and so on. For $n \leq 10^8$ the largest distance is 472. It occurs for $n_0 = 80\,545\,041$: $D(80545041) = 472$. The distribution of distances is shown in the next figure.

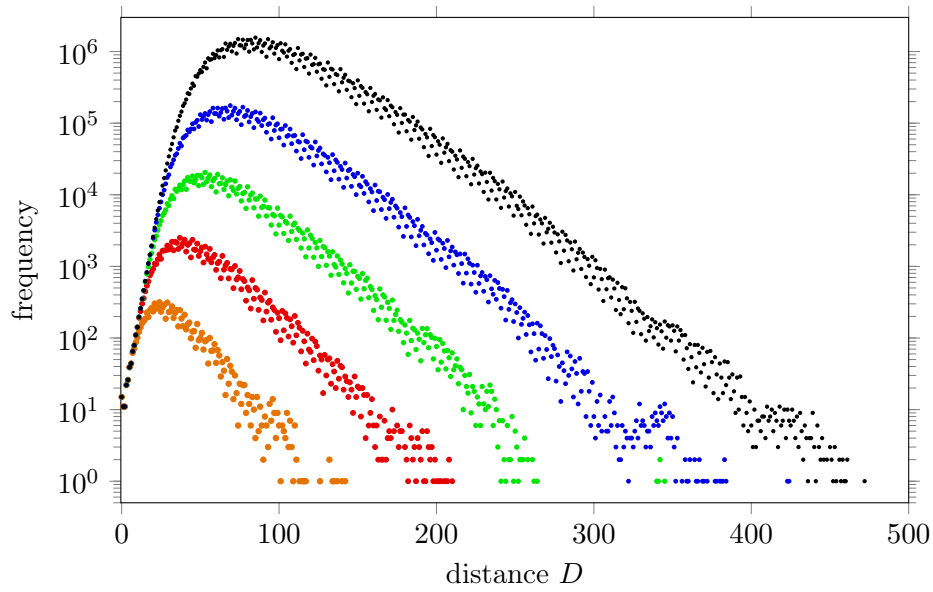

Figure 6.3: Distribution of distances for starting numbers smaller than or equal to: 10^4 (orange), 10^5 (red), 10^6 (green), 10^7 (blue), 10^8 (black).

The distribution of distances for numbers smaller than or equal to 10^8 is shown on a linear scale in the next figure.

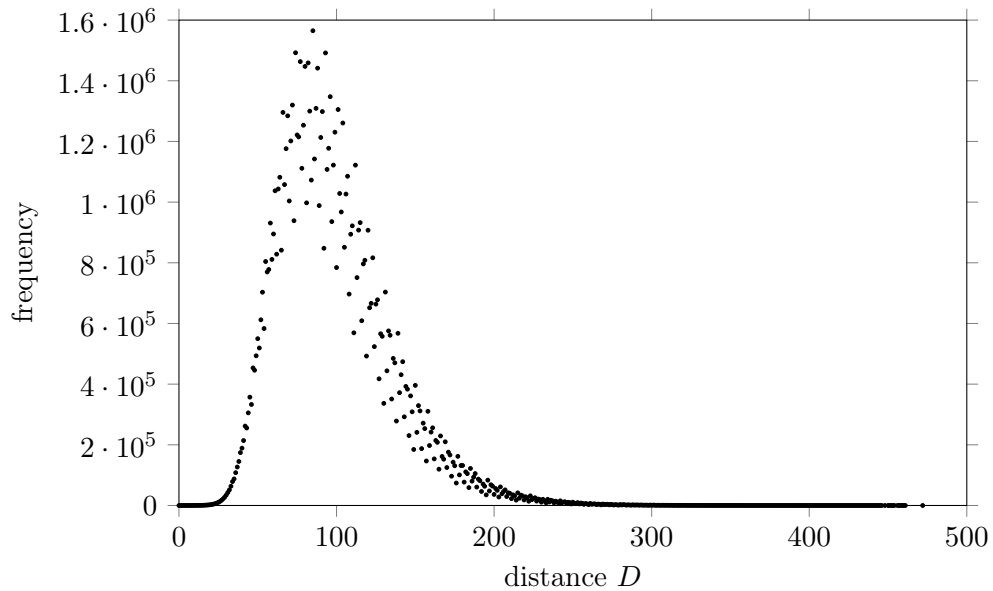

Figure 6.4: Distribution of distances for numbers smaller than or equal to 10^8 .

6.5 Even and odd orbit numbers

When an odd number of an orbit iterates to an even number $2^a b$ with b odd, there will be a successive even numbers in a row. Rows with successive odd numbers do also occur. We will start considering rows of even numbers.

For starting number 11 the orbit 11, 16, 8, 4, 2, 1, ... contains a row with four successive even numbers. Moreover, 11 is the smallest starting number for which a row with 4 successive orbit numbers appears. The smallest starting numbers for which the orbit contains a row with at least k successive even numbers are tabulated below for $n_0 \leq 10^8$.

n_0	1	2	3	8	11	29	29	128	171	512	683	1812	1812	7193	10923	32768	38837
k	0	1	2	3	4	5	6	7	8	9	10	11	12	13	14	15	16

n_0	77673	77673	524288	699051	2097152	2796203	5891589	5891589	33554432	44739243
k	17	18	19	20	21	22	23	24	25	26

For $k = 0, 1, 3, 7, 9, 15, 19, 21$ and 25 there holds precisely $n_0 = 2^k$. The next figure shows a plot of the length records of even rows.

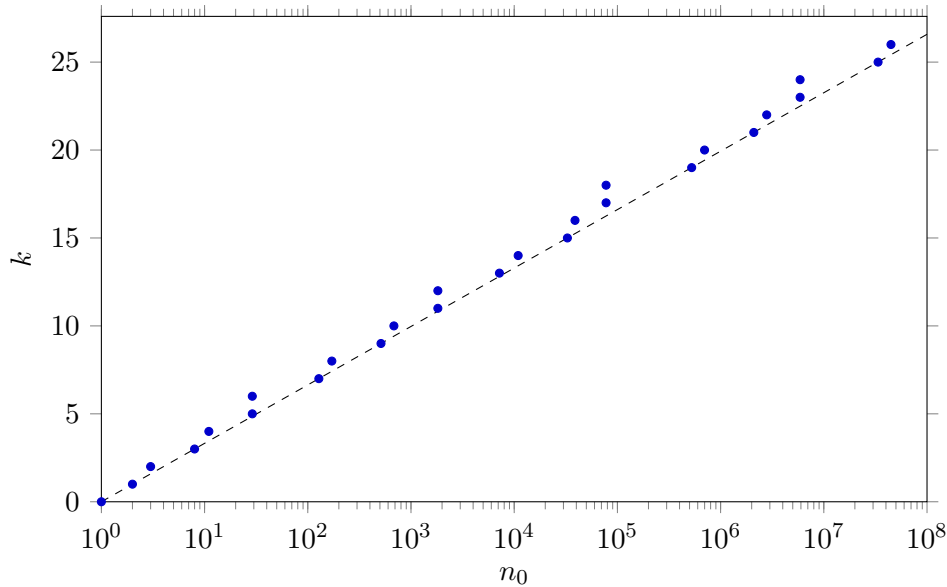

Figure 6.5: Records of length k of even rows against starting value n_0 of an orbit. The dashed curve is the function $n_0 = 2^k$.

The smallest starting number which leads to a row with 26 successive even orbit numbers is 44 739 243. The orbit is 44 739 243, $67\,108\,864 = 2^{26}$, 33 554 432, 16 777 216, 8 388 608, 4 194 304, 2 097 152, 1 048 576, 524 288, 262 144, 131 072, 65 536, 32 768, 16 384, 8192, 4096, 2048, 1024, 512, 256, 128, 64, 32, 16, 8, 4, 2, 1, ... Since $67\,108\,864 = 2^{26}$ the row descends in 26 steps from 2^{26} to 2.

Next we will look for orbits with two or more successive odd orbit numbers in a row. For this we only run through a cycle once. Otherwise everything would be dominated by the orbit 1,1,1,1,... For this situation the smallest starting numbers for which the orbit contains a row with at least k successive odd numbers are tabulated below for $n_0 \leq 10^8$.

n_0	1	9	9	17	33	65	129	153	321	321	2049	4097	8193	14565	32769	65537	131073
k	1	2	3	4	5	6	7	8	9	10	11	12	13	14	15	16	17

n_0	262145	524289	932069	2097153	4194305	8388609	16777217	26512145	26512145
k	18	19	20	21	22	23	24	25	26

The records do satisfy $n_0 = 2^k + 1$, except for $n = 1, 153, 321, 14\,565, 932\,069$ and $26\,512\,145$. The next figure shows a plot of the length records of odd rows.

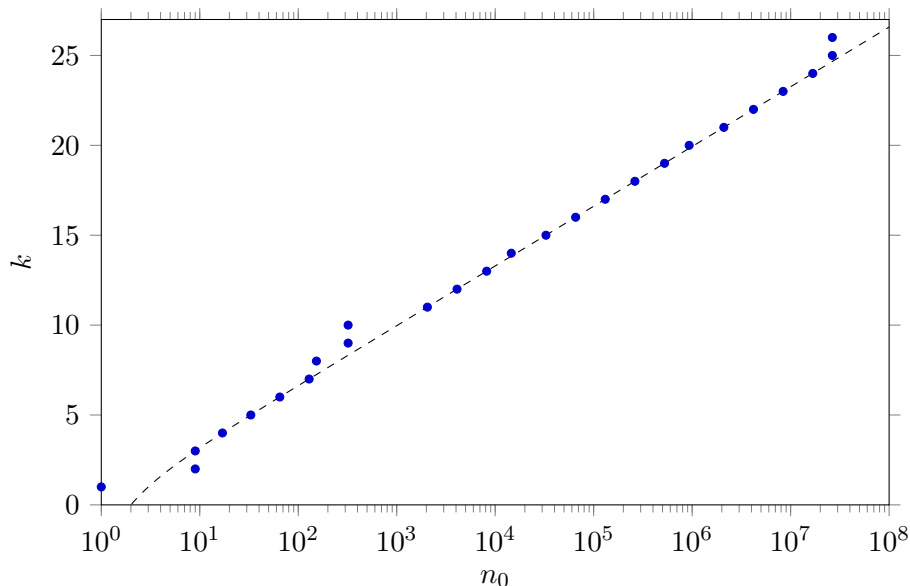

Figure 6.6: Records of length k of odd rows against starting value n_0 of an orbit. The dashed curve is the function $n_0 = 2^k + 1$.

For starting numbers n_0 which do satisfy the relation $n_0 = 2^k + 1$ the next number is $n_1 = (3(2^k + 1) - 1)/2 = (3 \cdot 2^k + 2)/2 = 3 \cdot 2^{k-1} + 1$. After two steps we have $n_2 = 3^2 \cdot 2^{k-2} + 1$. Repetition of the arithmetic leads to $n_m = 3^m \cdot 2^{k-m} + 1$. After k steps we have $n_k = 3^k + 1$, which is even. Hence, starting with $n_0 = 2^k + 1$ we obtain an orbit with a row of k odd numbers.

6.6 Records of maximums

Starting number 3 has orbit $\{3, 4, 2, 1, 1, \dots\}$. The maximum value of the orbit is 4, thus $M(3) = 4$. Starting number 5 has orbit $\{7, 10, 5, 7, \dots\}$. The maximum value of the orbit is 10. Thus $M(5) = 10$ which is a new maximum record. The maximum records $\mu(n)$ are tabulated below for $n_0 \leq 10^8$.

#	n	M record	#	n	M record	#	n	M record
1	1	1	13	1601	131 356	25	149 345	4 837 921 750
2	2	2	14	1889	413 344	26	337 761	4 862 920 456
3	3	4	15	3393	417 718	27	558 341	39 156 432 022
4	5	10	16	4097	957 664	28	839 429	39 246 157 990
5	9	28	17	6929	1 439 776	29	1 022 105	45 360 267 382
6	17	136	18	8193	1 594 324	30	1 467 393	3 293 075 932 912
7	33	244	19	10 497	2 908 468	31	7 932 689	7 033 004 986 294
8	65	820	20	11 025	40 219 750	32	8 612 097	15 270 716 514 700
9	129	2188	21	18 273	44 442 028	33	23 911 397	39 704 218 231 240
10	153	16 606	22	28 161	195 046 228	34	58 882 625	127 143 512 668 792
11	321	66 430	23	74 585	477 250 624	35	75 567 105	1 101 396 273 700 744
12	1425	83 188	24	85 265	510 919 012			

For $n_0 \leq 10^8$ a simultaneous odd row length record and orbit maximum record occurs for $n = 1, 9, 17, 33, 65, 129, 153, 321, 4097$ and 8193 . The records of orbit maximums have been plotted against starting value $n_0 \leq 10^8$ in the next figure.

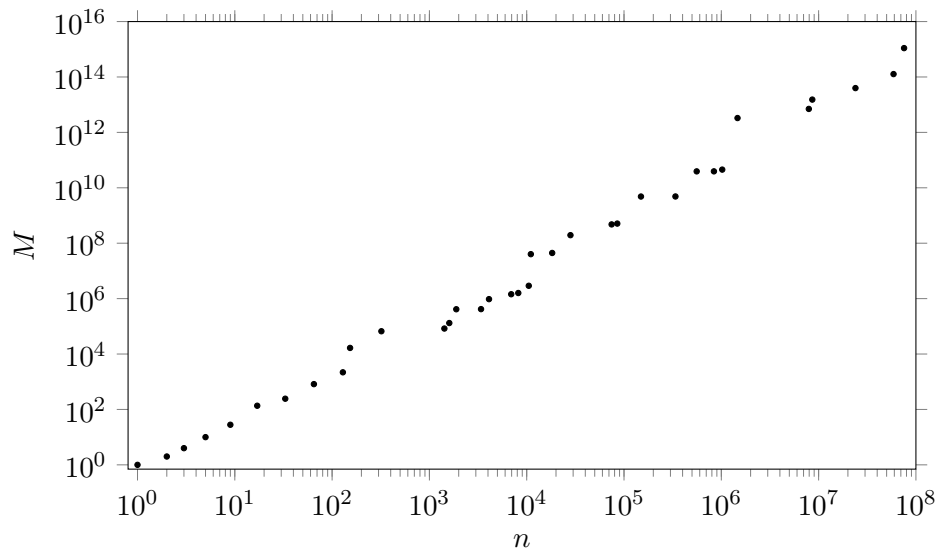

Figure 6.7: The records of orbit maximums M against starting value n_0 .

6.7 Records of distances

For the first few starting numbers the distances are $D(2) = 1$, $D(3) = 3$, $D(4) = 2$, $D(5) = 3$, $D(6) = 4$ and so on. We see the distance $D(6)$ does supersede $D(3)$. That is, $D(6)$ is a distance record. The next time a new distance record occurs is for starting number 9. The distance records are tabulated below for $n_0 \leq 10^8$.

#	n_0	D record	#	n_0	D record	#	n_0	D record	#	n_0	D record
1	2	1	9	57	20	17	903	72	25	6929	132
2	3	3	10	65	25	18	1209	74	26	7301	140
3	6	4	11	87	27	19	1425	98	27	9735	142
4	9	5	12	153	52	20	1689	103	28	11 025	153
5	15	7	13	305	53	21	2981	107	29	18 273	184
6	29	8	14	321	61	22	3975	109	30	21 657	189
7	39	10	15	641	62	23	5337	111	31	38 501	193
8	53	12	16	677	70	24	5505	117	32	47 897	195

#	n_0	D rec.	#	n_0	D rec.	#	n_0	D rec.	#	n_0	D rec.
33	54 021	201	41	253 959	235	49	3 051 879	350	57	38 748 977	444
34	54 081	203	42	266 469	237	50	3 387 153	366	58	40 821 969	452
35	64 025	206	43	304 901	250	51	3 759 257	382	59	43 005 861	460
36	64 097	208	44	361 365	255	52	5 012 343	384	60	80 545 041	472
37	85 463	210	45	482 817	341	53	6 546 273	424	61	0	0
38	113 951	212	46	858 341	345	54	13 092 545	425	62	0	0
39	126 465	228	47	1 144 455	347	55	16 347 225	438	63	0	0
40	149 889	233	48	2 288 909	348	56	19 374 489	443	64	0	0

The records of distances are plotted against starting number $n_0 \leq 10^8$ in the next figure.

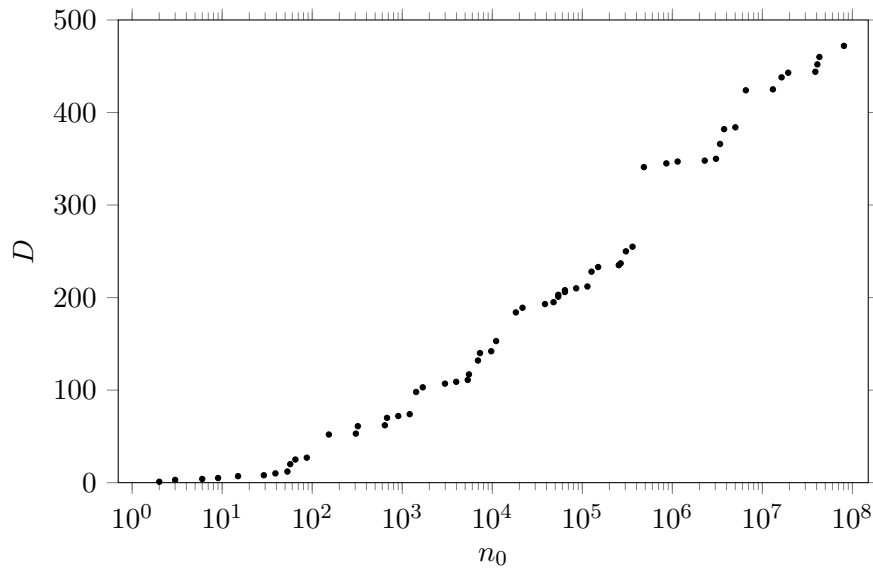

Figure 6.8: The records of distances against starting value n .

For $n_0 \leq 10^8$ a simultaneous orbit maximum record and distance record occurs for $n_0 = 2, 3, 65, 153, 321, 1425, 6929, 11\,025$ and $18\,273$.

6.8 Question

For the Negative Collatz iteration it is still an open question whether or not every orbit ends in one of the three cycles c_1, c_2 and c_3 ?

Chapter 7

Generalised Collatz

7.1 Introduction

We will consider the sequence of positive integers that occurs for the iteration

$$n_{k+1} = \begin{cases} \frac{3n_k + w}{2} & \text{if } n_k \equiv 1 \pmod{2} \\ \frac{n_k}{2} & \text{if } n_k \equiv 0 \pmod{2} \end{cases} \quad (7.1)$$

where n_i is a positive integer and where w is an odd integer. Suppose we are interested in the value of w for which a period 7 cycle occurs such that four members of the cycle are odd and three members of the cycle are even. An example of such an odd even ratio is a cycle which goes as (odd, odd, odd, even, odd, even, even). To such a cycle corresponds a *parity* cycle which contains a 1 if a cycle element is odd and a 0 if a cycle element is even. Thus to a (odd, odd, odd, even, odd, even, even) cycle corresponds the parity cycle (1, 1, 1, 0, 1, 0, 0). Let us look at the orbit for this parity cycle. Starting with number n_0 we successively obtain

$$\begin{aligned} n_1 &= \frac{3n_0 + w}{2}, \\ n_2 &= \frac{3n_1 + w}{2} = \dots = \frac{3^2 n_0 + (3^1 + 2^1) w}{2^2}, \\ n_3 &= \frac{3n_2 + w}{2} = \dots = \frac{3^3 n_0 + (3^2 + 3^1 \cdot 2^1 + 2^2) w}{2^3}, \\ n_4 &= \frac{n_3}{2} = \frac{3^3 n_0 + (3^2 + 3^1 \cdot 2^1 + 2^2) w}{2^4}, \\ n_5 &= \frac{3n_4 + w}{2} = \dots = \frac{3^4 n_0 + (3^3 + 3^2 \cdot 2^1 + 3 \cdot 2^2 + 2^4) w}{2^5}, \\ n_6 &= \frac{n_5}{2} = \frac{3^4 n_0 + (3^3 + 3^2 \cdot 2^1 + 3 \cdot 2^2 + 2^4) w}{2^6}, \\ n_7 &= \frac{n_6}{2} = \frac{3^4 n_0 + (3^3 + 3^2 \cdot 2^1 + 3 \cdot 2^2 + 2^4) w}{2^7}. \end{aligned}$$

For a period 7 cycle the condition $n_7 = n_0$ leads to

$$n_0 = \frac{(3^3 2^0 + 3^2 2^1 + 3^1 2^2 + 3^0 2^4) w}{2^7 - 3^4} = \frac{73w}{47}. \quad (7.2)$$

The starting number n_0 is an odd integer only if $w = 47$ or an odd multiple of 47. For $w = 47$ we have $n_0 = 73$. The corresponding cycle is $(73, 133, 223, 358, 179, 292, 146)$. For w an odd multiple of 47, $w = 47u$ say, we have $n_0 = 73u$ and the corresponding cycle, $(73u, 133u, 223u, 358u, 179u, 292u, 146u)$, is just a multiple of the cycle $(73, 133, 223, 358, 179, 292, 146)$. In the sequel we confine to the smallest value of w for which n_0 is integer.

In equation (7.2) the powers of 2 in the four terms between brackets are 1 smaller than the position of 1's in the parity cycle. In general, if the parity cycle of period p is denoted as $(k_1, k_2, k_3, \dots, k_p)$ and if the parity cycle includes odd numbers exactly q times at positions $r_1 < \dots < r_q$, then the unique solution which generates a cycle of period p in iteration scheme (7.1) is given by

$$n_0 = \frac{(3^{q-1}2^{r_1-1} + 3^{q-2}2^{r_2-1} + \dots + 3^02^{r_q-1})w}{2^p - 3^q}. \quad (7.3)$$

For example, parity cycle $(1, 1, 1, 1, 0, 0, 0)$ we obtain

$$n_0 = \frac{(3^32^0 + 3^22^1 + 3^12^2 + 3^02^3)w}{2^7 - 3^4} = \frac{65w}{47}. \quad (7.4)$$

Then, by taking $w = 47$ we obtain $n_0 = 65$ and cycle is $(65, 121, 205, 331, 520, 260, 130)$. Since there are $\binom{7}{4} = 35$ ways to position four 1's among 7 places, there are 35 different parity cycles. Furthermore, since $(0, 1, 1, 1, 1, 0, 0)$, $(0, 0, 1, 1, 1, 1, 0)$, $(0, 0, 0, 1, 1, 1, 1)$, $(1, 0, 0, 0, 1, 1, 1)$, etc. are just 7 periodic shifts of a unique parity cycle, there will be $\frac{35}{7} = 5$ unique cycles of length 7. To construct unique parity cycles in a systematic way as much as possible, we notice that for four 1's among 7 places there must at least exist a row of two or more adjacent 1's. We therefore can require $k_1 = 1$, $k_2 = 1$ and $k_7 = 0$. Since there are $\binom{4}{2} = 6$ ways to position two 1's among 4 places, we obtain six possibilities for unique parity cycles. The six possibilities are $(1, 1, 1, 1, 0, 0, 0)$, $(1, 1, 1, 0, 1, 0, 0)$, $(1, 1, 0, 1, 1, 0, 0)$, $(1, 1, 1, 0, 0, 1, 0)$, $(1, 1, 0, 1, 0, 1, 0)$ and $(1, 1, 0, 0, 1, 1, 0)$. Next we observe that possibility $(1, 1, 0, 0, 1, 1, 0)$ is just a shift of possibility $(1, 1, 0, 1, 1, 0, 0)$. So, we arrive at five unique parity cycles. The parity cycles and the corresponding orbit cycles are:

$$\begin{aligned} (1, 1, 1, 1, 0, 0, 0) &\rightarrow (65, 121, 205, 331, 520, 260, 130), \\ (1, 1, 1, 0, 1, 0, 0) &\rightarrow (73, 133, 223, 358, 179, 292, 146), \\ (1, 1, 0, 1, 1, 0, 0) &\rightarrow (85, 151, 250, 125, 211, 340, 170), \\ (1, 1, 1, 0, 0, 1, 0) &\rightarrow (89, 157, 259, 412, 206, 103, 178), \\ (1, 1, 0, 1, 0, 1, 0) &\rightarrow (101, 175, 286, 143, 238, 119, 202). \end{aligned}$$

Now we can proceed in two ways. The first way is to fix $w = 47$ and look for all periods p of the corresponding cycles. The second way is too look for all w values which deliver period 7 cycles.

7.2 Cycles for $(3n + 47)/2$ iteration

Here we will consider the orbits of positive integers which occur for the iteration

$$n_{k+1} = \begin{cases} \frac{3n_k + 47}{2} & \text{if } n_i \equiv 1 \pmod{2} \\ \frac{n_k}{2} & \text{if } n_i \equiv 0 \pmod{2}. \end{cases} \quad (7.5)$$

For this iteration the starting numbers of period p cycles with q odds, are given by

$$n_0 = \frac{(3^{q-1}2^{r_1-1} + 3^{q-2}2^{r_2-1} + \dots + 3^0 2^{r_q-1}) 47}{2^p - 3^q}. \quad (7.6)$$

Again $r_1 < \dots < r_q$ are the positions of the q odds in the parity cycle.

Let \mathcal{G} be the greatest common divisor of $(3^{q-1}2^{r_1-1} + 3^{q-2}2^{r_2-1} + \dots + 3^0 2^{r_q-1})$ and $2^p - 3^q$.

If $\mathcal{G} = 1$ the value of n_0 is only a positive integer if $2^p - 3^q = 47$ or if $2^p - 3^q = 1$. The condition $2^p - 3^q = 1$ is satisfied if $p = 2$ and $q = 1$. For period 2 parity cycle $(1, 0)$ we obtain $n_0 = 3^0 2^0 \cdot 47 = 47$. The corresponding period 2 cycle is $(47, 94)$. The condition $2^p - 3^q = 47$ is satisfied probably only for $p = 7$ and $q = 4$. This leads to the five period 7 cycles as derived in the previous section.

For $\mathcal{G} \neq 1$ the value of n_0 is only an integer if $2^p - 3^q = 47\mathcal{G}$. Such a situation occurs for the period 18 parity cycle $(1, 1, 0, 1, 0, 0, 1, 0, 0, 1, 1, 0, 0, 0, 1, 0, 0, 0)$. That is, $p = 18$ and $q = 7$ and

$$n_0 = \frac{(3^6 2^0 + 3^5 2^1 + 3^4 2^3 + 3^3 2^6 + 3^2 2^9 + 3^1 2^{10} + 3^0 2^{14}) 47}{2^{18} - 3^7} = \frac{27655 \cdot 47}{259957} = \frac{5 \cdot 5531 \cdot 47}{47 \cdot 5531} = 5.$$

The corresponding period 18 cycle is

$(5, 31, 70, 35, 76, 38, 19, 52, 26, 13, 43, 88, 44, 22, 11, 40, 20, 10)$.

Another situation with $\mathcal{G} \neq 1$ occurs for the period 28 parity cycle $(1, 1, 1, 0, 0, 1, 1, 1, 1, 1, 0, 1, 1, 0, 1, 1, 0, 0, 1, 0, 0, 0, 0)$. Now $p = 28$ and $q = 16$ and

$$n_0 = \frac{119887625 \cdot 47}{225388735} = \frac{5^3 \cdot 11 \cdot 13 \cdot 19 \cdot 353 \cdot 47}{5 \cdot 11 \cdot 13 \cdot 19 \cdot 47 \cdot 353} = 5^2.$$

The corresponding period 28 cycle is $(25, 61, 115, 196, 98, 49, 97, 169, 277, 439, 682, 341, 535, 826, 413, 643, 988, 494, 247, 394, 197, 319, 502, 251, 400, 200, 100, 50)$.

For $n_0 \leq 10^5$ and $w = 47$ there is no cycle with a period larger than 28.

7.3 Period records

Period 28 for $w = 47$ is not a period record. Already for $w = 23$ a period 43 cycle occurs. That record was preceded by a period 31 cycle for $w = 17$. For $w > 47$ we obtain the records $p = 66$ for $w = 61$, $p = 100$ for $w = 85$ and so on, where p denotes the cycle period. Given a cycle which contains a period record, we will denote its smallest element as c min, and the smallest starting number for which the orbit ends in such a cycle as n_0 min. For positive odd $w < 2000$ the records for p , c min and n_0 min are tabulated below.

w	p	c min	n_0 min	w	p	c min	n_0 min	w	p	c min	n_0 min
1	2	1	1	107	106	1	1	371	222	25	1
5	27	187	123	125	118	899	387	509	262	5	3
17	31	23	9	139	136	11	1	563	426	19	1
23	43	41	1	143	140	7	1	1135	476	13	1
29	65	3811	2531	197	141	5	1	1163	526	13	1
61	66	235	175	253	162	13	3	1307	636	1	1
85	100	7	1	313	200	35	1	1699	737	23	1

The data for w and p records are plotted in the next figure.

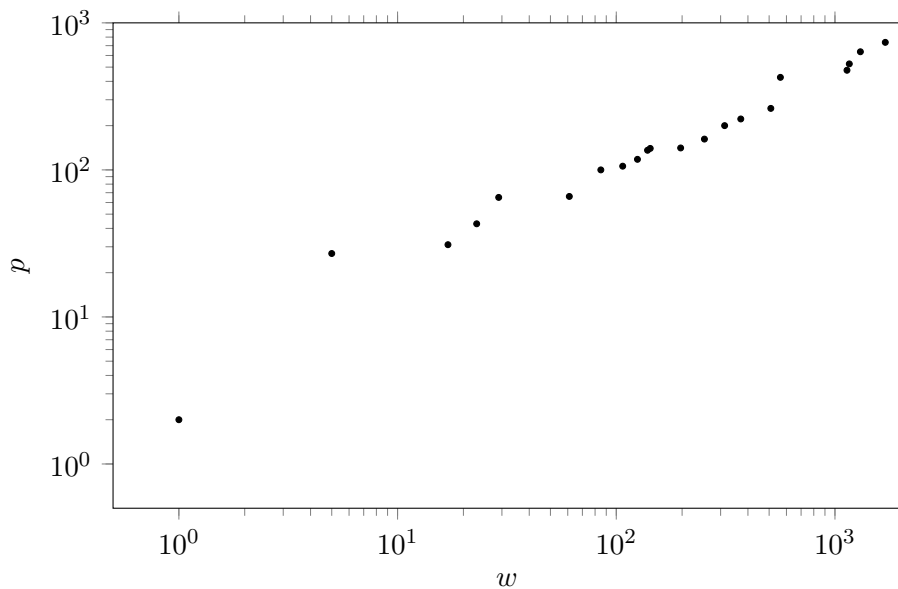

Figure 7.1: A plot for the records of cycle periods against w for $n_0 \leq 10^5$.

7.4 Values of w for period 7 cycles

In the first section of this chapter we explained why five different period 7 cycles with 4 odd elements do occur for $w = 47$. In this section we will systematically derive the value for w for which period 7 cycles occur with other than 4 odd elements.

We start with a period 7 cycle without odd elements. The parity cycle is $(0, 0, 0, 0, 0, 0, 0)$. That is, $n_7 = \frac{n_0}{2^7}$. The condition $n_7 = n_0$ has the trivial solution $n_0 = 0$. Actually, $n_0 = 0$ is a period 1 cycle or fixed point. We will confine to period 7 cycles which are not a multiple of smaller cycles and count $n_0 = 0$ to the trivial period 1 cycle (0) .

Next we consider a period 7 cycle with 1 odd element. The only unique possibility for the parity cycle is $(1, 0, 0, 0, 0, 0, 0)$ since other possibilities like $(0, 1, 0, 0, 0, 0, 0)$, $(0, 0, 1, 0, 0, 0, 0)$, etc. are just periodic shifts of $(1, 0, 0, 0, 0, 0, 0)$. According to equation 7.3 the parity cycle $(1, 0, 0, 0, 0, 0, 0)$ corresponds to $n_0 = \frac{3^0 2^0 w}{2^7 - 3^1} = \frac{w}{125}$. The smallest value of w for which n_0 is integer is $w = 125$. Then $n_0 = 1$ and the cycle is $(1, 64, 32, 16, 8, 4, 2)$. The shifted parity cycles $(0, 1, 0, 0, 0, 0, 0)$, $(0, 0, 1, 0, 0, 0, 0)$, etc. just correspond to cycles starting with the elements 64, 32, etc.

Next we consider a period 7 cycle with 2 odd elements. The unique possibilities are $(1, 1, 0, 0, 0, 0, 0)$, $(1, 0, 1, 0, 0, 0, 0)$ and $(1, 0, 0, 1, 0, 0, 0)$. To $(1, 1, 0, 0, 0, 0, 0)$ corresponds $n_0 = \frac{(3^1 2^0 + 3^0 2^1)w}{2^7 - 3^2} = \frac{5w}{119}$. The smallest value of w for which n_0 is integer is $w = 119$. Then $n_0 = 5$ and the cycle is $(5, 67, 160, 80, 40, 20, 10)$. To $(1, 0, 1, 0, 0, 0, 0)$ corresponds $n_0 = \frac{(3^1 2^0 + 3^0 2^2)w}{2^7 - 3^2} = \frac{7w}{119} = \frac{w}{17}$. The smallest value of w for which n_0 is integer is $w = 17$. Then $n_0 = 1$ and the cycle is $(1, 10, 5, 16, 8, 4, 2)$. To $(1, 0, 0, 1, 0, 0, 0)$ corresponds $n_0 = \frac{(3^1 2^0 + 3^0 2^3)w}{2^7 - 3^2} = \frac{11w}{119}$. The smallest value of w for which n_0 is integer is $w = 119$. Then $n_0 = 11$ and the cycle is $(11, 76, 38, 19, 88, 44, 22)$.

For period 7 cycle with 3 odd elements the unique possibilities are $(1, 1, 1, 0, 0, 0, 0)$, $(1, 1, 0, 1, 0, 0, 0)$, $(1, 1, 0, 0, 1, 0, 0)$, $(1, 1, 0, 0, 0, 1, 0)$ and $(1, 0, 1, 0, 1, 0, 0)$. These five parity cycles correspond with the cycles $(19, 79, 169, 304, 152, 76, 38)$, $(23, 85, 178, 89, 184, 92, 46)$, $(31, 97, 196, 98, 49, 124, 62)$, $(47, 121, 232, 116, 58, 29, 94)$ and $(37, 106, 53, 130, 65, 148, 74)$ respectively all for $w = 101$.

For period 7 cycles with 5 odd elements the unique possibilities are $(1, 1, 1, 1, 1, 0, 0)$, $(1, 1, 1, 1, 0, 1, 0)$ and $(1, 1, 1, 0, 1, 1, 0)$. These three parity cycles correspond with the cycles $(211, 259, 331, 439, 601, 844, 422)$, $(227, 283, 367, 493, 682, 341, 454)$ and $(251, 319, 421, 574, 287, 373, 502)$ respectively all for $w = -115$.

For period 7 cycles with 6 odd elements there is only one unique possibility: $(1, 1, 1, 1, 1, 1, 0)$. It corresponds with the cycle $(665, 697, 745, 817, 925, 1087, 1330)$ for $w = -601$.

Finally, for a period 7 cycle with 7 odd elements the parity cycle is $(1, 1, 1, 1, 1, 1, 1)$. It corresponds with the period 7 cycle $(1, 1, 1, 1, 1, 1, 1)$ for $w = -1$. It is a multiple of the fixed point (1) and will be discarded for period 7 cycles. The results for period 7 cycles are tabulated below.

w	parity cycle	cycle
125	(1, 0, 0, 0, 0, 0, 0)	(1, 64, 32, 16, 8, 4, 2)
119	(1, 1, 0, 0, 0, 0, 0)	(5, 67, 160, 80, 40, 20, 10)
17	(1, 0, 1, 0, 0, 0, 0)	(1, 10, 5, 16, 8, 4, 2)
119	(1, 0, 0, 1, 0, 0, 0)	(11, 76, 38, 19, 88, 44, 22)
101	(1, 1, 1, 0, 0, 0, 0)	(19, 79, 169, 304, 152, 76, 38)
101	(1, 1, 0, 1, 0, 0, 0)	(23, 85, 178, 89, 184, 92, 46)
101	(1, 1, 0, 0, 1, 0, 0)	(31, 97, 196, 98, 49, 124, 62)
101	(1, 1, 0, 0, 0, 1, 0)	(47, 121, 232, 116, 58, 29, 94)
101	(1, 0, 1, 0, 1, 0, 0)	(37, 106, 53, 130, 65, 148, 74)
47	(1, 1, 1, 1, 0, 0, 0)	(65, 121, 205, 331, 520, 260, 130)
47	(1, 1, 1, 0, 1, 0, 0)	(73, 133, 223, 358, 179, 292, 146)
47	(1, 1, 0, 1, 1, 0, 0)	(85, 151, 250, 125, 211, 340, 170)
47	(1, 1, 1, 0, 0, 1, 0)	(89, 157, 259, 412, 206, 103, 178)
47	(1, 1, 0, 1, 0, 1, 0)	(101, 175, 286, 143, 238, 119, 202)
-115	(1, 1, 1, 1, 1, 0, 0)	(211, 259, 331, 439, 601, 844, 422)
-115	(1, 1, 1, 1, 0, 1, 0)	(227, 283, 367, 493, 682, 341, 454)
-115	(1, 1, 1, 0, 1, 1, 0)	(251, 319, 421, 574, 287, 373, 502)
-601	(1, 1, 1, 1, 1, 1, 0)	(665, 697, 745, 817, 925, 1087, 1330)

There are 1, 3, 5, 5, 3, 1 period 7 cycles with 1, 2, 3, 4, 5, 6 odd elements respectively. The w values which lead to periodic 7 cycles are -601, -115, 17, 47, 101, 119 and 125.

The following observation for cycle elements might be of interest: If we add the even elements of a cycle and subtract the odd elements, then the result is w times the number of odd elements. Examples are:

$$64 + 32 + 16 + 8 + 4 + 2 - 1 = 125 = w$$

$$160 + 80 + 40 + 20 + 10 - 5 - 67 = 238 = 2 \cdot 119 = 2w$$

$$10 + 16 + 8 + 4 + 2 - 1 - 5 = 34 = 2 \cdot 17 = 2w$$

$$304 + 152 + 76 + 38 - 19 - 79 - 169 = 303 = 3 \cdot 101 = 3w$$

$$1330 - 665 - 697 - 745 - 817 - 925 - 1087 = -3606 = 6 \cdot -601 = 6w$$

Let us denote the sum of the even elements minus the sum of the odd elements of a cycle as h and the number of odd elements of a cycle as q . Then we observe the following relation between h and w and q :

$$h = wq. \quad (7.7)$$

7.5 Cycles with a given period

In this section we consider cycles occurring in the iteration (7.1). The smallest cycles are period 1 cycles or fixed points. To the parity cycle (0) corresponds the fixed point (0) for any value of w . For this case $h = wq$ is satisfied for every w since $h = 0$ and $q = 0$. To the parity cycle (1) corresponds the fixed point (1) for $w = -1$. The table is

w	q	parity cycle	cycle	Σ even	Σ odd	h
\times	0	(0)	(0)	0	0	0
-1	1	(1)	(1)	0	1	-1

There is one unique period 2 parity cycle which is not a multiple of a fixed point: (1, 0). The corresponding cycle is (1, 2) for $w = 1$. The table is

w	q	parity cycle	cycle	Σ even	Σ odd	h
1	1	(1, 0)	(1, 2)	2	1	1

There are two unique period 3 parity cycles which is not a multiple of a fixed point: (1, 0, 0) and (1, 1, 0). The corresponding cycles are (1, 4, 2) for $w = 5$ and (5, 7, 10) for $w = -1$. The table is

w	q	parity cycle	cycle	Σ even	Σ odd	h
5	1	(1, 0, 0)	(1, 4, 2)	6	1	5
-1	2	(1, 1, 0)	(5, 7, 10)	10	12	-2

For unique parity cycles with period 4, 5 and 6 the tables are

w	q	parity cycle	cycle	Σ even	Σ odd	h
13	1	(1, 0, 0, 0)	(1, 8, 4, 2)	14	1	13
7	2	(1, 1, 0, 0)	(5, 11, 20, 10)	30	16	14
-11	3	(1, 1, 1, 0)	(19, 23, 29, 38)	38	71	-33

w	q	parity cycle	cycle	Σ even	Σ odd	h
29	1	(1, 0, 0, 0, 0)	(1, 16, 8, 4, 2)	30	1	29
23	2	(1, 1, 0, 0, 0)	(5, 19, 40, 20, 10)	70	24	46
23	2	(1, 0, 1, 0, 0)	(7, 22, 11, 28, 14)	64	18	46
5	3	(1, 1, 1, 0, 0)	(19, 31, 49, 76, 38)	114	99	15
5	3	(1, 1, 0, 1, 0)	(23, 37, 58, 29, 46)	104	89	15
-49	4	(1, 1, 1, 1, 0)	(65, 73, 85, 103, 130)	130	326	-196

w	q	parity cycle	cycle	Σ even	Σ odd	h
61	1	(1, 0, 0, 0, 0, 0)	(1, 32, 16, 8, 4, 2)	62	1	61
11	2	(1, 1, 0, 0, 0, 0)	(1, 7, 16, 8, 4, 2)	30	8	22
55	2	(1, 0, 1, 0, 0, 0)	(7, 38, 19, 56, 28, 14)	136	26	110
37	3	(1, 1, 1, 0, 0, 0)	(19, 47, 89, 152, 76, 38)	266	155	111
37	3	(1, 1, 0, 1, 0, 0)	(23, 53, 98, 49, 92, 46)	236	125	111
37	3	(1, 1, 0, 0, 1, 0)	(31, 65, 116, 58, 29, 62)	236	125	111
-17	4	(1, 1, 1, 1, 0, 0)	(65, 89, 125, 179, 260, 130)	390	458	-68
-17	4	(1, 1, 1, 0, 1, 0)	(73, 101, 143, 206, 103, 146)	352	420	-68
-179	5	(1, 1, 1, 1, 1, 0)	(211, 227, 251, 287, 341, 422)	422	1317	-895

The table for unique period 7 cycles has already been shown in the previous section. If $a(p)$ is the number of unique cycles with period p then the sequence $a(p)$ for $p = 1, 2, 3, 4, 5, \dots$ goes as 2, 1, 2, 3, 6, 9, 18, The latter sequence is known as sequence A001037 of the OEIS [2].

7.6 Cycles with $|w| = 1$

Let the numerator and denominator of equation 7.3 be Nw and D respectively. That is

$$N = 3^{q-1}2^{r_1-1} + 3^{q-2}2^{r_2-1} + \dots + 3^02^{r_q-1} \quad (7.8)$$

and

$$D = 2^p - 3^q, \quad (7.9)$$

where p is the cycle period, q is the number of odd elements in the cycle and the r_i , $i = 1, 2, \dots, q$, are the positions of the odd elements in the cycle. For an alternative way to describe N we write a period p parity cycle as (c_1, c_2, \dots, c_p) , where c_k is either 0 or 1. Of course, $c_1 + c_2 + \dots + c_p = q$. Let C_k be given by

$$C_k = \sum_{m=k+1}^p c_m. \quad (7.10)$$

Then N is also given by

$$N = \sum_k^p c_k 3^{C_k} 2^{k-1}. \quad (7.11)$$

To obtain a cycle with $w = -1$ the denominator D should be negative and $|D|$ should be a divisor of N . For this situation we already met two cases: (1) and (5, 7, 10). For the fixed point (1) we have $N = 3^02^0 = 1$ and $D = 2^1 - 3^1 = -1$. For the period 3 cycle (5, 7, 10) we have $N = 3^12^0 + 3^02^1 = 5$ and $D = 2^3 - 3^2 = -1$. The reason for these cycles is clear: $|D| = 1$ always is a divisor of N . There happens to be a case with $|D| > 1$: (17, 25, 37, 55, 82, 41, 61, 91, 136, 68, 34) with parity cycle (1, 1, 1, 1, 0, 1, 1, 1, 0, 0, 0). For this case we have $N = 3^62^0 + 3^52^1 + 3^42^2 + 3^32^3 + 3^22^5 + 3^12^6 + 3^02^7 = 2363 = 17 \cdot 139$ and $D = 2^{11} - 3^7 = -139$. This case occurs because 139 happens to be a divisor of 2363.

To obtain a cycle with $w = 1$ the denominator D should be positive and a divisor of N . For this situation we already met one case: (1, 2). For the trivial cycle (1, 2) we have $N = 3^02^0 = 1$ and $D = 2^2 - 3^1 = 1$. Since $D = 1$ it always is a divisor of N . To day, cases with $D > 1$ have not been found.

The closer $|D|$ to 1 the larger the probability for $|D|$ to be a divisor of N . In general, a relatively small denominator occurs if $2^p \approx 3^q$. However, for increasing period the value of $2^p \approx 3^q$ is almost of the same order as 2^p . The larger the period, the smaller the probability for a cycle to exist.

7.7 Further generalization

Throughout this chapter we considered the iteration (7.1), where the 1 in $(3n + 1)/2$ is generalized to w . A further generalization is obtained by considering the iteration

$$n_{k+1} = \begin{cases} \frac{vn_k + w}{2} & \text{if } n_k \equiv 1 \pmod{2} \\ \frac{n_k}{2} & \text{if } n_k \equiv 0 \pmod{2} \end{cases}, \quad (7.12)$$

where v and w are odd integers. However, for an odd v larger than 3 there is a large probability for orbits to run to infinity. For instance, for the iteration

$$n_{k+1} = \begin{cases} \frac{5n_k + 1}{2} & \text{if } n_k \equiv 1 \pmod{2} \\ \frac{n_k}{2} & \text{if } n_k \equiv 0 \pmod{2} \end{cases} \quad (7.13)$$

the orbit starting with 7 goes as 7, 18, 9, 23, 58, 29, 73, 183, 458, 229, 573, 1433, 8958, 4479, 11198, ... It is the sequence A185455 of the OEIS [2]. The orbit runs to large values: for $k = 199$ the element n_k of the orbit exceeds 10^{15} , for $k = 2176$ the orbit exceeds 10^{100} , for $k = 21572$ the orbit exceeds 10^{1000} and for $k = 207216$ the orbit exceeds 10^{10000} . No wonder it is conjectured that the orbit goes to infinity, although it still is an open question.

For the $(5n + w)/2$ iteration we found by inspection for several w the smallest positive n_0 for which the orbit seems to run to infinity, see the next table.

w	-29	-27	-25	-23	-21	-19	-17	-15	-13	-11	-9	-7	-5	-3	-1
n_0	1	1	43	19	95	1	11	37	7	25	17	33	19	17	9

w	1	3	5	7	9	11	13	15	17	19	21	23	25	27	29
n_0	7	5	13	19	15	5	5	7	5	1	11	3	21	5	1

Chapter 8

\mathcal{M} and \mathcal{W} function

8.1 Introduction

Inspired by the Collatz function we create the following iteration:

$$n_{k+1} = \begin{cases} p_{n_k} - n_k & \text{if } n_k \text{ is odd,} \\ \frac{n_k}{2} & \text{if } n_k \text{ is even,} \end{cases} \quad (8.1)$$

where p_n is the n -th prime. For brevity we will denote the iteration as

$$n_{k+1} = \mathcal{M}(n_k), \quad (8.2)$$

where the \mathcal{M} function is defined as

$$\mathcal{M}(n) = \begin{cases} p_n - n & \text{if } n \text{ is odd,} \\ \frac{n}{2} & \text{if } n \text{ is even.} \end{cases} \quad (8.3)$$

For instance, for $n_0 = 7$ we have $n_1 = p_7 - 7 = 17 - 7 = 10$, $n_2 = 10/2 = 5$, $n_3 = p_5 - 5 = 11 - 5 = 6$, and so on. The orbit is 7, 10, 5, 6, 3, 2, 1, 1, 1, ...

8.2 Cycles of the \mathcal{M} function

For starting values $n_0 \leq 10^8$ the iteration $n_{k+1} = \mathcal{M}(n_k)$ contains one fixed point: $c_1 = 1$, and

one period 7 cycle: $c_2 = (211, 1086, 543, 3376, 1688, 844, 422)$.

Not all orbits end in c_1 or c_2 . Instead, some orbit seems to grow to infinity. The growth is more or less irregular. The smallest n_0 which seems to exhibit a growth to infinity is 35. The orbit goes as 35, 114, 57, 212, 106, 53, 188, 94, 47, 164, 82, 41, 138, 69, 278, 139, 658,

329, 1878, 939, 6454, 3227, 26 534, 13 267, 129 786, ... After 89 steps the orbit is arrived at $n_{89} = 1\,299\,179\,087\,596\,844\,773$. The next n_0 which seems to exhibit a growth to infinity and which is not already in the orbit of 35, is 55. The orbit goes as: 55, 202, 101, 446, 223, 1186, 593, 3746, 1873, 14218, 7109, 64 728, ... After 57 steps the orbit is arrived at $n_{57} = 334\,499\,083\,750\,963\,285$.

8.3 Statistics of cycle arrivals

For $n_0 \leq 10^8$ the fractions of starting numbers for which the orbit arrives in c_1 , c_2 or grows to infinity are plotted in the next figure.

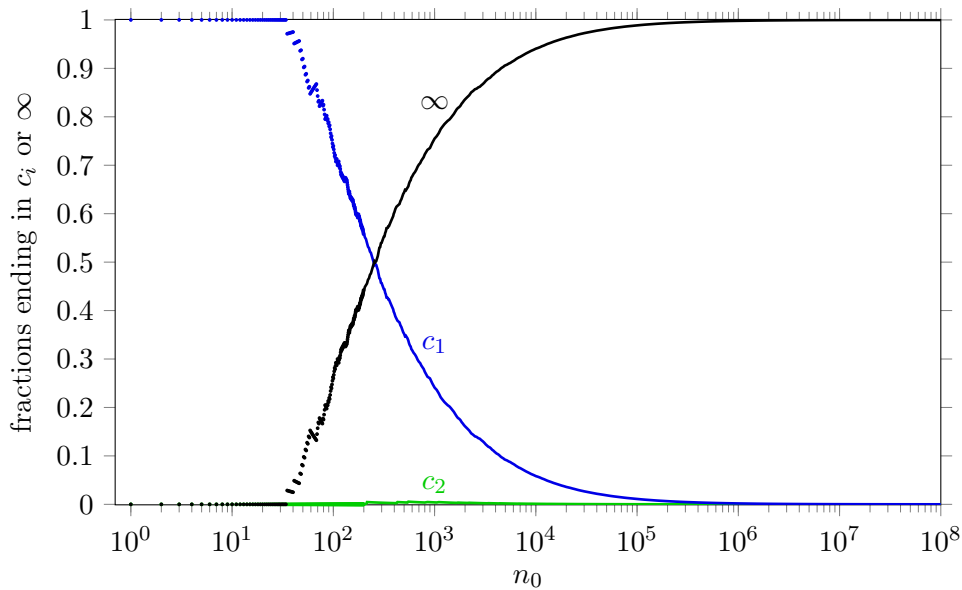

Figure 8.1: The fractions of starting numbers of which the orbit arrives in c_1 (blue), c_2 (green) or grows to ∞ (black).

Each fraction approaches a limit value for $n_0 \rightarrow \infty$. The limit values of the fractions for which the orbit ends in c_1 , c_2 and ∞ are 0, 0 and 1 respectively.

The fraction of c_2 is for all n_0 negligible. For small n_0 most orbits arrive at c_1 . For large n_0 most orbits grow to infinity. The tipping point is near $n_0 = 255$. Even if p_{n_0}/n_0 would be a constant, a larger n_0 would lead to a larger probability for an orbit to grow to infinity. This behavior is enhanced by the fact that p_n/n_0 grows as $\ln n_0$. A theoretical approximation of the ratio p_n/n is [4]

$$\nu_n = \ln n + \ln \ln n - 1 + \frac{\ln \ln n - 2}{\ln n} - \frac{(\ln \ln n)^2 - 6 \ln \ln n + 11}{2(\ln n)^2}. \quad (8.4)$$

A more practical approximation of the ratio p_n/n is

$$\mu_n = 0.71 + 1.058 \ln n. \quad (8.5)$$

8.4 Approximation for the n -th prime

Let us denote the ratio p_n/n as ρ_n :

$$\rho_n = \frac{p_n}{n}. \quad (8.6)$$

In the next figure we have plotted the ρ_n and the approximations ν_n and μ_n .

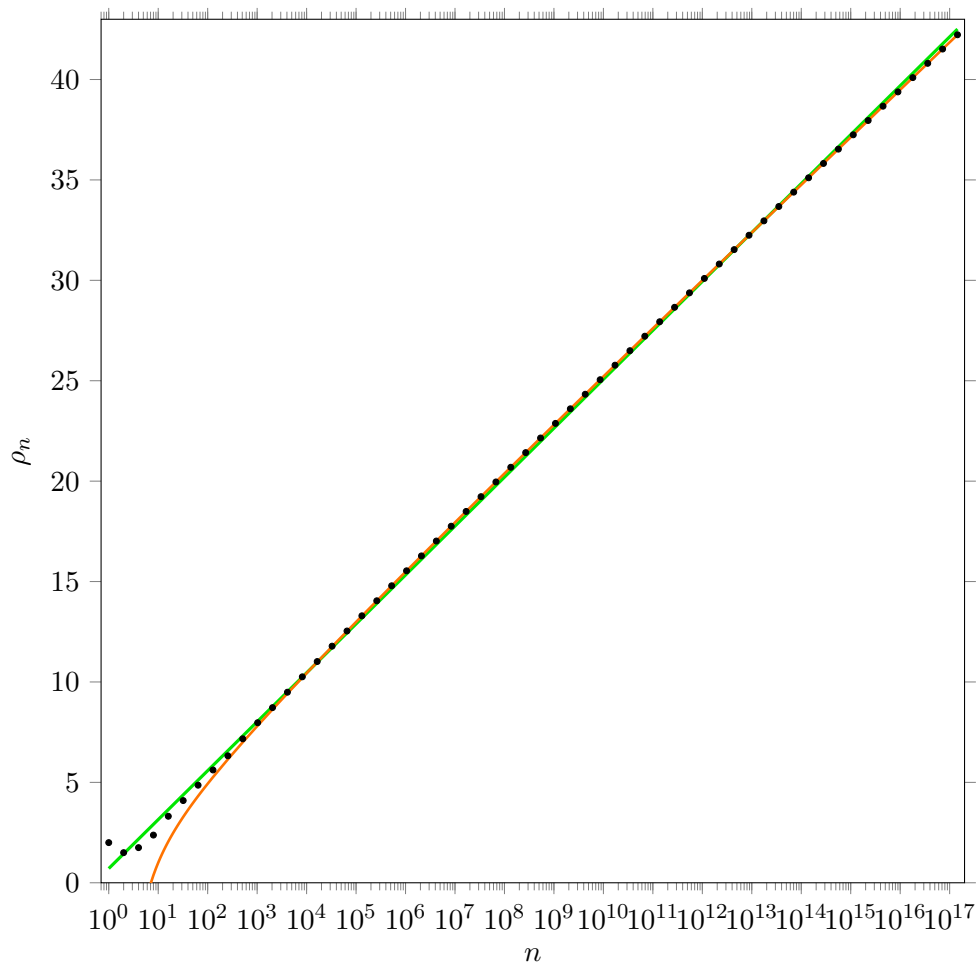

Figure 8.2: The value of ρ_n for $n = 2^k$, with $0 \leq k \leq 57$ an integer (black dots), the approximation ν_n (orange) and the approximation μ_n (green).

To get a more detailed impression of the accuracy of the approximations, the values of ρ , ν/ρ and μ/ρ are shown for various n in the next table.

n	ρ	ν/ρ	μ/ρ
1	2.000000000	–	0.3550
2	1.500000000	-11.97559627	0.9622
3	1.666666667	-3.52143336	1.1234
4	1.750000000	-1.64223131	1.2438
5	2.200000000	-0.67160691	1.0967
6	2.166666667	-0.29397721	1.2026
7	2.42857143	-0.02372752	1.1401
8	2.375000000	0.15823572	1.2253
9	2.555555556	0.28103411	1.1875
10	2.900000000	0.34455333	1.0849
15	3.133333333	0.61388557	1.1410
20	3.550000000	0.69814204	1.0928
30	3.766666667	0.84277500	1.1438
40	4.325000000	0.83858348	1.0666
50	4.580000000	0.86478913	1.0587
100	5.410000000	0.91153109	1.0318
150	5.753333333	0.95013674	1.0448
200	6.115000000	0.95432174	1.0328
500	7.142000000	0.97590997	1.0200
10^3	7.919000000	0.98468935	1.0126
10^4	10.47290000	0.99678386	0.9982
10^5	12.99709000	0.99916230	0.9918
10^6	15.48586300	0.99968550	0.9897
10^7	17.94246730	1.00000099	0.9900
10^8	20.38074743	1.00000190	0.9911
10^9	22.80176349	1.00000846	0.9927
10^{10}	25.20978006	1.00000585	0.9945
10^{11}	27.60727303	1.00000464	0.9964
10^{12}	29.99622428	1.00000312	0.9982
10^{13}	32.37805089	1.00000211	1.0001
10^{14}	34.75385759	1.00000145	1.0018
10^{15}	37.12450805	1.00000101	1.0034
10^{16}	39.49069139	1.00000071	1.0050
10^{17}	41.85296581	1.00000051	1.0065

For $n > 1166$ the approximation ν is more accurate than the approximation μ . Anyway, the important conclusion is that p_n is much larger than n for large n . For instance, $p_n/n \approx 20$ for odd $n \approx 10^8$. So, for odd $n_i \approx 10^8$ the next iterate is $n_{i+1} = p_{n_i} - n_i$ and the next to next iterate n_{i+2} is smaller than n_i only if $p_{n_i} - n_i$ is divisible by 2^5 or a higher power of 2. The probability for $p_{n_i} - n_i$ to be divisible by 2^5 is small. Even if n_{i+2} happens to be smaller than n_i , than n_{i+2} is most probably still large enough to be followed by a growth. For this reason a cycle with elements larger than 10^8 is not very likely. Although very unlikely, it is not impossible. We are therefore left with the question whether or not (1) and (211, 1086, 543, 3376, 1688, 844, 422) are the only cycles of the \mathcal{M} function.

8.5 The \mathcal{W} function

A variation of the \mathcal{M} function can be created by changing the minus sign into a plus sign.

$$n_{k+1} = \begin{cases} p_{n_k} + n_k & \text{if } n_k \text{ is odd,} \\ \frac{n_k}{2} & \text{if } n_k \text{ is even,} \end{cases} \quad (8.7)$$

where p_n is the n -th prime. To distinguish it from the \mathcal{M} function we will call it the \mathcal{W} function:

$$n_{k+1} = \mathcal{W}(n_k), \quad (8.8)$$

where

$$\mathcal{W}(n) = \begin{cases} p_n + n & \text{if } n \text{ is odd,} \\ \frac{n}{2} & \text{if } n \text{ is even.} \end{cases} \quad (8.9)$$

For instance, for $n_0 = 7$ we have $n_1 = p_7 + 7 = 17 + 7 = 24$, $n_2 = 24/2 = 12$, $n_3 = 12/2 = 6$, $n_4 = 6/2 = 3$, $n_5 = p_3 + 3 = 5 + 3 = 8$, and so on. The orbit is 7, 24, 12, 6, 3, 8, 4, 2, , 1, 3, 8,

8.6 Cycles of the \mathcal{W} function

For starting values $n_0 \leq 10^8$ the iteration $n_{k+1} = \mathcal{W}(n_k)$ contains

one period 5 cycle: $c_1 = (1, 3, 8, 4, 2)$,

one period 8 cycle: $c_2 = (235, 1718, 859, 7520, 3760, 1880, 940, 470)$,

one period 10 cycle: $c_3 = (15, 62, 31, 158, 79, 480, 240, 120, 60, 30)$,

two period 18 cycles:

$$c_4 = (21, 94, 47, 258, 129, 856, 428, 214, 107, 694, 347, 2688, 1344, 672, 336, 168, 84, 42),$$

$$c_5 = (51, 284, 142, 71, 424, 212, 106, 53, 294, 147, 1000, 500, 250, 125, 816, 408, 204, 102).$$

Also here not all orbits end in periodic cycles. Instead, some orbit seems to grow to infinity.

The growth is more or less irregular. The smallest n_0 which seems to exhibit a growth to infinity is 13. The orbit goes as 13, 54, 27, 130, 65, 378, 189, 1318, 659, 5592, 2796, 1398, 699, 5972, 2986, 1493, 13996, ... After 80 steps the orbit is arrived at $n_{80} = 1977693361846020549$. The next n_0 which seems to exhibit a growth to infinity is 17. The orbit goes as: 17, 76, 38, 19, 86, 43, 234, 117, 760, 380, 190, 95, 594, 297, 2248, ... After 83 steps the orbit is arrived at $n_{83} = 445705128169301879$.

8.7 Statistics of cycle arrivals

For $n_0 \leq 10^8$ the fractions of starting numbers for which the orbit arrives in one of the cycles or grows to infinity are plotted in the next figure.

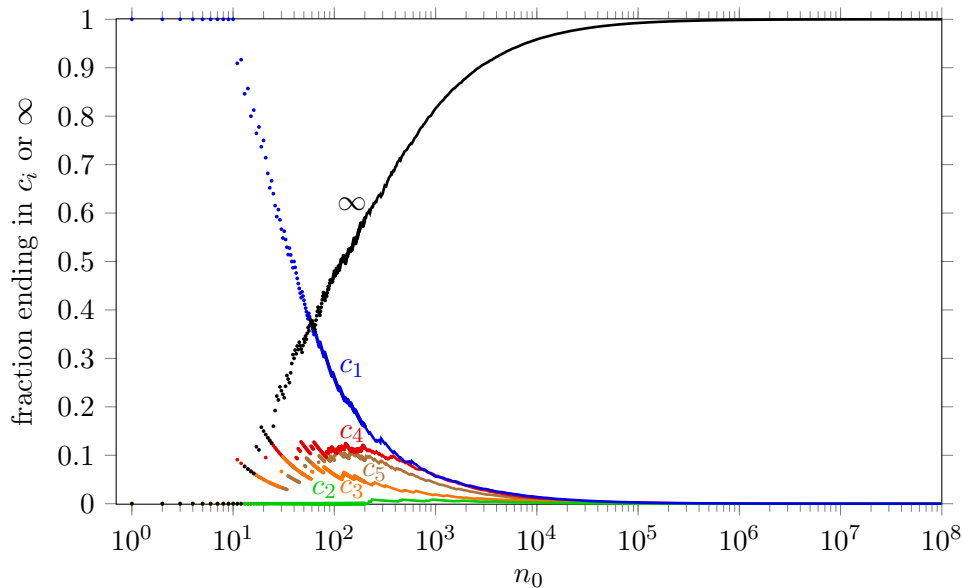

Figure 8.3: The fractions of starting numbers of which the orbit arrives in c_1 (blue), c_2 (green), c_3 (orange), c_4 (red), c_5 (brown) or grows to ∞ (black).

Each fraction approaches a limit value for $n_0 \rightarrow \infty$. The limit values of the fractions of starting numbers for which the orbit ends in c_1 , c_2 , c_3 , c_4 , c_5 and ∞ are 0, 0, 0, 0, 0 and 1 respectively.

The question arises whether or not c_1 , c_2 , c_3 , c_4 and c_5 are the only cycles of the \mathcal{W} function.

Chapter 9

Reversal of digits

9.1 Introduction

From an arbitrary number we can create a second number by reversing the order of digits. Subtraction of the smallest from the largest of the two numbers leads to a new number. We give some examples:

From 962 we obtain $962 - 269 = 693$.

From 8374 we obtain $8374 - 4738 = 3636$.

In this chapter we will consider the iteration

$$n_{k+1} = \max(n_k, r_k) - \min(n_k, r_k), \quad (9.1)$$

where r_k is the digit reversal of n_k . We will call it the digit reversal iteration. If we work for instance with 4-digit numbers, than numbers smaller than 1000 are preceded by zero's to make them 4-digit numbers: $123 \rightarrow 0123$, $64 \rightarrow 0064$, $7 \rightarrow 0007$, etc.

For instance, for the 4-digit number $n_0 = 3447$ we obtain $r_0 = 7443$ and

$n_1 = 7443 - 3447 = 3996$. Repeating the iteration we obtain

$$n_2 = 6993 - 3996 = 2997, \quad n_3 = 7992 - 2997 = 4995, \quad n_4 = 5994 - 4995 = 0999,$$

$$n_5 = 9990 - 0999 = 8991, \quad n_6 = 8991 - 1998 = 6993, \quad n_7 = 6993 - 3996 = 2997.$$

That is, $n_7 = n_2 = 2997$. So, $(0999, 8991, 6993, 2997, 4995)$ is a period 5 cycle. It can also be written as $999 \cdot (1, 9, 7, 3, 5)$.

When the iteration is applied to $n_0 = 4086$ we successively obtain

$$n_1 = 6804 - 4086 = 2718, \quad n_2 = 8172 - 2718 = 5454, \quad n_3 = 5454 - 4545 = 0909,$$

$$n_4 = 9090 - 0909 = 8181, \quad n_5 = 8181 - 1818 = 6363, \quad n_6 = 6363 - 3636 = 2727,$$

$$n_7 = 7272 - 2727 = 4545, \quad n_8 = 5454 - 4545 = 0909.$$

That is, $n_8 = n_3 = 0909$. So, $(0909, 8181, 6363, 2727, 4545)$ is a period 5 cycle. It can also be written as $909 \cdot (1, 9, 7, 3, 5)$.

When the iteration is applied to $n_0 = 0025$ we successively obtain

$$\begin{aligned} n_1 &= 5200 - 0025 = 5175, & n_2 &= 5715 - 5175 = 0540, & n_3 &= 0540 - 0450 = 0090, \\ n_4 &= 0900 - 0090 = 0810, & n_5 &= 0810 - 0180 = 0630, & n_6 &= 0630 - 0360 = 0270, \\ n_7 &= 0720 - 0270 = 0450, & n_8 &= 0540 - 0450 = 0090. \end{aligned}$$

We see $(0090, 0810, 0630, 0270, 0450) = 90 \cdot (1, 9, 7, 3, 5)$ is a period 5 cycle.

When the iteration is applied to $n_0 = 0176$ we successively obtain

$$n_1 = 6710 - 0176 = 6534, \quad n_2 = 6534 - 4356 = 2178, \quad n_3 = 8712 - 2178 = 6534.$$

That is, $n_3 = n_1$. So, $(2178, 6534)$ is a period 2 cycle. It can also be written as $2 \cdot 3^2 \cdot 11^2 \cdot (1, 3)$.

It turns out that the orbit for almost all 4-digit numbers ends at one of the four foregoing periodic cycles. The only exceptions are the 100 palindrome numbers 0000, 0110, 0220, ..., 0990, 1001, 1111, 1221, ..., 1991, 2002, 2112, 2222,, 9889, 9999. These 100 numbers are mapped on the trivial fixed point (0000).

As before we let the distance be the number of steps required to reach a periodic cycle. For 4-digit numbers it is the number of steps required to arrive at either one of the cycles (0000), (0999, 8991, 6993, 2997, 4995), (0909, 8181, 6363, 2727, 4545), (0090, 0810, 0630, 0270, 0450) or (2178, 6534). For the numbers 0 through 9999 the frequency of distances is shown in the table below.

distance	0	1	2	3	4	5	6	7	8	9	10	11	12
# n_0	18	1572	1170	1416	1376	724	728	604	656	704	564	172	296

There are two ways to generalize the iteration. The first way is by considering numbers with other than 4 digits. The second way is by considering numbers in other bases. We start with considering numbers with m digits in base 10.

9.2 Reversal of digits for m -digit numbers

For $m = 1$ there is one fixed point: (0). The numbers 1, 2, ..., 9 are mapped on the fixed point.

For $m = 2$ there is one fixed point: (00), and one period 5 cycle: (09, 81, 63, 27, 45).

The numbers 11, 22, ..., 99 are mapped to the fixed point (00). For all other 2-digit numbers the orbit arrives at the cycle (09, 81, 63, 27, 45). To see this we let d_1 and d_0 be the digits of a 2-digit number $n_0 = 10d_1 + d_0$. If $d_1 = d_0$ then $n_1 = 00$. If $d_1 \neq d_0$ then $n_1 = 10|d_1 - d_0| + |d_0 - d_1| = 9|d_1 - d_0|$. The latter is either an even multiple of 9 or a member of the cycle (09, 81, 63, 27, 45). The even multiples of 9 arrive after one step at the cycle

(09, 81, 63, 27, 45) since 18, 36, 54, 72 and 90 are mapped on 63, 27, 09, 45 and 81 respectively. The distance frequencies for 2-digit numbers can be explained as follows. The fixed point 00 and the cycle elements 09, 81, 63, 27, 45 are 6 cases with distance 0. From $n_1 = 9|d_1 - d_0|$ we see that for the 9 cases where $d_1 = d_0 \neq 0$, that is for $n_0 \in \{11, 22, 33, 44, 55, 66, 77, 88, 99\}$, we have $n_1 = 00$. That are 9 cases with distance 1. For the 45 cases where $|d_1 - d_0|$ is odd and $n_0 \notin (09, 81, 63, 27, 45)$ the successor n_1 is a member of the cycle (09, 81, 63, 27, 45). That are 45 cases with distance 1. In total we have $45 + 9 = 54$ cases with distance 1. For the 40 cases where $|d_1 - d_0|$ is even and $d_1 \neq d_0$, the successor n_1 is an even multiple of 9 and n_2 is a member of the cycle (09, 81, 63, 27, 45). That are 40 cases with distance 2. Presented in a distance table:

distance	0	1	2	3	4	5	6	7	8	9
# n_0	6	54	40	0	0	0	0	0	0	0

For $m = 3$ there is one fixed point: (000), and one period 5 cycle: (099, 891, 693, 297, 495). The palindrome numbers for which the last digit equals the first digit, are mapped to the fixed point (000). For all other 3-digit numbers the orbit arrives at the period 5 cycle (099, 891, 693, 297, 495). To see this we let d_2, d_1 and d_0 be the digits of a number $n_0 = 100d_2 + 10d_1 + d_0$. If $d_2 = d_0$ then $n_1 = 000$ else $n_1 = 100|d_2 - d_0| + 10(d_1 - d_1) + |d_0 - d_2| = 99|d_2 - d_0|$. The latter is either an even multiple of 99 or a member of the cycle (099, 891, 693, 297, 495). The even multiples of 99 arrive after one step at the cycle (099, 891, 693, 297, 495) since 198, 396, 594, 792 and 990 are mapped on 693, 297, 099, 495 and 891 respectively.

The distance frequencies for 3-digit numbers can be explained as follows. The fixed point 000 and the cycle elements 099, 891, 693, 297, 495 are 6 cases with distance 0. From $n_1 = 99|d_2 - d_0|$ we see that for the 99 cases where $d_2 = d_0$ and $n_0 \neq 000$ we have $n_1 = 000$. That are 99 cases with distance 1. For the 495 cases where $|d_2 - d_0|$ is odd and $n_0 \notin (099, 891, 693, 297, 495)$ the successor n_1 is a member of the cycle (099, 891, 693, 297, 495). That are 495 cases with distance 1. In total we have $495 + 99 = 594$ cases with distance 1. For the 400 cases where $|d_2 - d_0|$ is even and $d_2 \neq d_0$ the successor n_1 is an even multiple of 99 and n_2 is a member of the cycle (099, 891, 693, 297, 495). That are 400 cases with distance 2. For 3-digit numbers the distance table is:

distance	0	1	2	3	4	5	6	7	8	9
# n_0	6	594	400	0	0	0	0	0	0	0

The distance frequencies for 3-digit numbers are related to the distance frequencies for 2-digit

numbers. Since the digit d_1 is not present in the equation $n_1 = 99|d_2 - d_0|$ for 3-digit numbers the arithmetic is determined by the first and the last digit comparable with the situation for 2-digit numbers. For the 40 2-digit numbers with distance 2 we can plug in an arbitrary digit between d_1 and d_0 to obtain the 400 3-digit numbers with distance 2. We cannot simply plug in an arbitrary digit between d_1 and d_0 of a 2-digit member of a cycle in order to create a 3-digit cycle member. For example, if we take the 2-digit cycle member 81 and plug in the 0 through 9 in between the 8 and the 1, we obtain 801, 811, 821, ..., 891. They are all mapped on 693 which is part of the cycle (099, 891, 693, 297, 495). That is, the number of cycle members for 3-digit numbers is the same as for 2-digit numbers. The number 891 in the example has distance 0, while the numbers 801, 801, 811, 821, ..., 881 have distance 1. Therefore the frequency of 3-digit numbers with distance 1 is 10 times the frequency of 2-digit numbers with distance 1 added with 9 times the frequency of 2-digit numbers with distance 0.

Let us denote the frequency of m -digit numbers with distance D as $f_m(D)$ then the relation can be summarized as $f_3(2) = 10f_2(2)$, $f_3(1) = 10f_2(1) + 9f_2(0)$ and $f_3(0) = f_2(0)$.

For $m = 4$ there are

one fixed point: (0000),

one period 2 cycle: (2178, 6534), and

three period 5 cycles:

(0090, 0810, 0630, 0270, 0450),

(0999, 8991, 6993, 2997, 4995) and

(0909, 8181, 6363, 2727, 4545).

A general 4-digit starting number is given by $n_0 = 1000d_3 + 100d_2 + 10d_1 + d_0$, where d_0 through d_3 are the four digits. In the palindrome case $d_0 = d_3$ and $d_1 = d_2$ the n_0 is mapped to the fixed point (0000). In case $d_3 = d_0$ and $d_2 \neq d_1$ the first and last digit of n_1 is zero. The two digits in between behave as $m = 2$ numbers. So, in case $d_3 = d_0$ and $d_2 \neq d_1$, the orbit arrives at (0090, 0810, 0630, 0270, 0450). For 4-digit numbers the distance table is:

distance	0	1	2	3	4	5	6	7	8	9
# n_0	18	1572	117	1416	1376	724	728	604	656	704
distance	10	11	12	13	14	15	16	17	18	19
# n_0	564	172	296	0	0	0	0	0	0	0

For $m = 5$ there are

one fixed point: (00000),

one period 2 cycle: (21978, 65934), and

three period 5 cycles:

(09999, 89991, 69993, 29997, 49995),
 (00990, 08910, 06930, 02970, 04950) and
 (09009, 81081, 63063, 27027, 45045).

For 5-digit numbers the distance table is:

distance	0	1	2	3	4	5	6	7	8	9
# n_0	18	15882	1170	14160	13760	7240	7280	6040	6560	7040
distance	10	11	12	13	14	15	16	17	18	19
# n_0	5640	1720	2960	0	0	0	0	0	0	0

As for 3-digit and 2-digit numbers the distance frequencies for 5-digit and 4-digit numbers are related. The relation is $f_5(0) = f_4(0)$, $f_5(1) = 10f_4(1) + 9f_4(0)$ and $f_5(D) = 10f_4(D)$ for $D \geq 2$.

For $m = 6$ there are

one fixed point: (000000),

two period 2 cycles:

(219978, 659934) and

(021780, 065340),

seven period 5 cycles:

(099999, 899991, 699993, 299997, 499995),

(009990, 089910, 069930, 029970, 049950),

(090009, 810081, 630063, 270027, 450045),

(000900, 008100, 006300, 002700, 004500),

(009090, 081810, 063630, 027270, 045450),

(099099, 891891, 693693, 297297, 495495) and

(090909, 818181, 636363, 272727, 454545),

one period 9 cycle: (010989, 978021, 057142, 615384, 131868, 736263, 373626, 252747, 494505),

and one period 18 cycle: (043659, 912681, 726462, 461835, 076329, 847341, 703593, 308286, 374517, 340956, 318087, 462726, 164538, 670923, 341847, 406296, 286308, 517374).

For 6-digit numbers the distance frequencies are plotted in a diagram, see next figure.

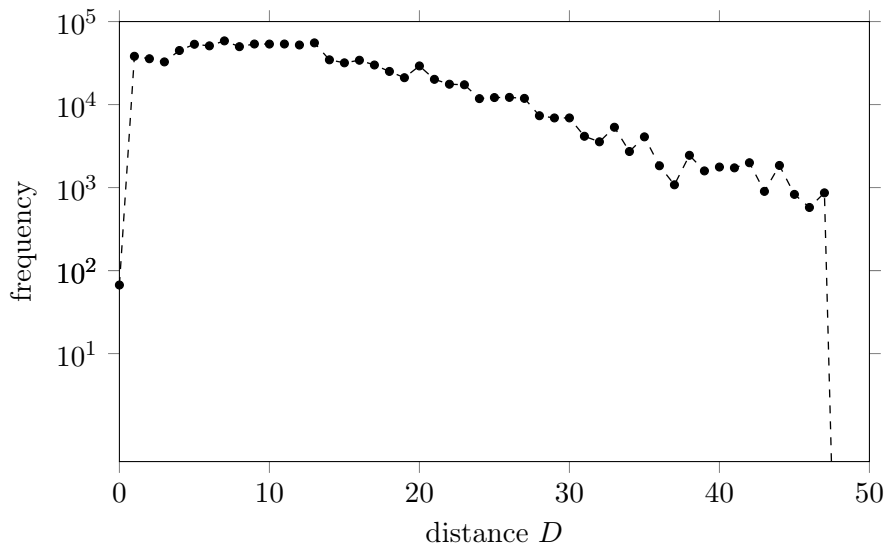

Figure 9.1: Distribution of distances for 6-digit numbers for the digit reversal iteration.

For $m = 7$ there are: one fixed point: (0000000),

two period 2 cycles:

(0219780, 0659340) and

(2199978, 6599934),

seven period 5 cycles:

(0999999, 8999991, 6999993, 2999997, 4999995),

(0099990, 0899910, 0699930, 0299970, 0499950),

(0900009, 8100081, 6300063, 2700027, 4500045),

(0009900, 0089100, 0069300, 0029700, 0049500),

(0090090, 0810810, 0630630, 0270270, 0450450),

(0990099, 8910891, 6930693, 2970297, 4950495),

(0909909, 8189181, 6369363, 2729727, 4549545),

one period 9 cycle: (0109989, 9789021, 8579142, 6159384, 1319868, 7369263, 3739626, 2529747, 4949505) and

one period 18 cycle (0439659, 9129681, 7260462, 4619835, 0769329, 8470341, 7039593, 3080286, 3740517, 3409956, 3189087, 4620726, 1649538, 6709923, 3410847, 4069296, 2860308, 5170374).

For 7-digit numbers the distance frequencies are plotted in the next diagram.

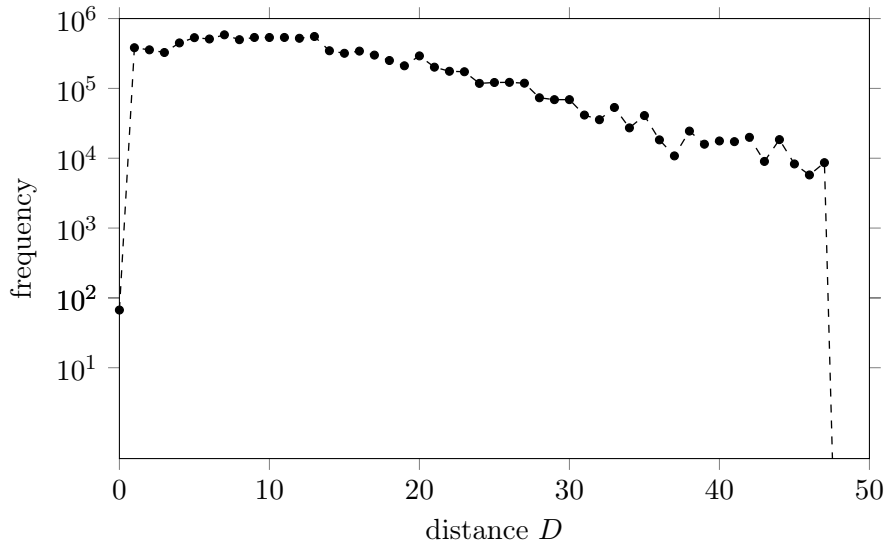

Figure 9.2: Distribution of distances for 7-digit numbers for the digit reversal iteration.

The relation between the distance frequencies of 7-digit numbers and 6-digit numbers is $f_7(0) = f_6(0)$, $f_7(1) = 10f_6(1) + 9f_6(0)$ and $f_7(D) = 10f_6(D)$ for $D \geq 2$.

In summary, in base 10 the relation between distance frequencies of $2k + 1$ digit and $2k$ digit numbers is

$$f_{2k+1}(D) = \begin{cases} f_{2k}(D) & \text{if } D = 0 \\ 10f_{2k}(D) + 9f_{2k}(0) & \text{if } D = 1 \\ 10f_{2k}(D) & \text{if } D \geq 2. \end{cases} \quad (9.2)$$

These equations satisfy the requirement

$$\sum_{D=0}^{\infty} f_{2k+1}(D) = 10 \sum_{D=0}^{\infty} f_{2k}(D). \quad (9.3)$$

For 8-digit numbers we have one fixed point: (00000000),

four period 2 cycles:

(21999978, 65999934),

(02199780, 06599340),

(00217800, 00653400),

(21782178, 65346534),

fifteen period 5 cycles:

(09999999, 89999991, 69999993, 29999997, 49999995),

(00999990, 08999910, 06999930, 02999970, 04999950),

(09000009, 81000081, 63000063, 27000027, 45000045),

(00099900, 00899100, 00699300, 00299700, 00499500),
 (00900090, 08100810, 06300630, 02700270, 04500450),
 (00009000, 00081000, 00063000, 00027000, 00045000),
 (00090900, 00818100, 00636300, 00272700, 00454500),
 (09090909, 81818181, 63636363, 27272727, 45454545),
 (09990999, 89918991, 69936993, 29972997, 49954995),
 (09099909, 81899181, 63699363, 27299727, 45499545),
 (09900099, 89100891, 69300693, 29700297, 49500495),
 (09009009, 81081081, 63063063, 27027027, 45045045),
 (00990990, 08918910, 06936930, 02972970, 04954950),
 (00909090, 08181810, 06363630, 02727270, 04545450),
 (09909099, 89181891, 69363693, 29727297, 49545495),

two period 9 cycles:

(01099989, 97899021, 85799142, 61599384, 13199868, 73699263, ..., 25299747, 49499505),
 (00109890, 09780210, 08571420, 06153840, 01318680, 07362630, ..., 02527470, 04945050),

one period 10 cycle:

(07781229, 84437541, 69864093, 30817197, 48354606, 12290778, ..., 28026918, 53935164),

one period 14 cycle:

(11436678, 76226733, 42464466, 23981958, 61936974, 13973058, ..., 48737106),

and two period 18 cycles:

(04399659, 91299681, 72600462, 46199835, 07699329, ..., 28600308, 51700374), and
 (00436590, 09126810, 07264620, 04618350, 00763290, ..., 02863080, 05173740).

9.3 Digit reversal iteration in base 2

In the previous section we considered 1- through 8-digit numbers in base 10. Here we will consider 1 through 9-digit numbers in base 2.

For 1-digit numbers in base 2 we have two orbits: $0 \rightarrow 0$ and $1 \rightarrow 0$. That is, (0) is the single fixed point.

For 2-digit numbers in base 2 we have four different starting values with orbits: $00 \rightarrow 00$, $01 \rightarrow 01$, $10 \rightarrow 01$ and $11 \rightarrow 00$. That is, (00) and (01) are fixed points. The numbers 10 and 11 both have distance 1. The numbers 10 and 11 in base 2 are written as 2 and 3 in base 10. Sometimes one writes $10_2 = 2_{10}$ and $11_2 = 3_{10}$ or shortly $10 = 2_{10}$ and $11 = 3_{10}$ if the left side base is clear.

For 3-digit numbers in base 2 we have: $000 \rightarrow 000$, $001 \rightarrow 011$, $010 \rightarrow 000$, $011 \rightarrow 011$, $100 \rightarrow 011$, $101 \rightarrow 000$, $110 \rightarrow 011$, $111 \rightarrow 000$. That is, $(000) = (0_{10})$ and $(011) = (3_{10})$ are

two fixed points. The 6 other numbers have distance 1 to these fixed points.

For 4-digit numbers in base 2 we have 4 fixed points: (0000) , $(0010) = (2_{10})$, $(0101) = (5_{10})$ and $(0111) = (7_{10})$. It can be seen as follows: for a fixed point $x = 8d_3 + 4d_2 + 2d_1 + d_0$ with digits d_3, d_2, d_1, d_0 the digit reversal should deliver a twice as large number. That is,

$$8d_0 + 4d_1 + 2d_2 + d_3 = 2(8d_3 + 4d_2 + 2d_1 + d_0) . \quad (9.4)$$

It is reduced to

$$16d_3 + 6d_2 = 6d_0 . \quad (9.5)$$

The solution is $d_3 = 0$, $d_2 = d_0$ and d_1 may be either 0 or 1. Indeed for $d_2 = d_0 = 0$ and $d_1 = 0$ we have $x = 0000$, for $d_2 = d_0 = 0$ and $d_1 = 1$ we have $x = 0010$, for $d_2 = d_0 = 1$ and $d_1 = 0$ we have $x = 0101$ and for $d_2 = d_0 = 1$ and $d_1 = 1$ we have $x = 0111$. Among the 12 other 4-digit numbers there are 10 numbers with distance 1 and 2 numbers with distance 2.

For 5-digit numbers in base 2 we have 4 fixed points: (00000) , $(00110) = (6_{10})$, $(01001) = (9_{10})$ and $(01111) = (15_{10})$. It can be seen as follows: for a fixed point $x = 16d_4 + 8d_3 + 4d_2 + 2d_1 + d_0$ with digits d_4, d_3, d_2, d_1, d_0 the digit reversal should deliver a twice as large number:

$$16d_0 + 8d_1 + 4d_2 + 2d_3 + d_4 = 2(16d_4 + 8d_3 + 4d_2 + 2d_1 + d_0) . \quad (9.6)$$

This condition is reduced to

$$31d_4 + 14d_3 + 4d_2 = 4d_1 + 14d_0 . \quad (9.7)$$

The solution is $d_4 = 0$, $d_3 = d_0$ and $d_2 = d_1$ may be either 0 or 1. Indeed for $d_3 = d_0 = 0$ and $d_2 = d_1 = 0$ we have $x = 00000$, for $d_3 = d_0 = 0$ and $d_2 = d_1 = 1$ we have $x = 00110$, for $d_3 = d_0 = 1$ and $d_2 = d_1 = 0$ we have $x = 01001$ and for $d_3 = d_0 = 1$ and $d_2 = d_1 = 1$ we have $x = 01111$. Among the 28 other 4-digit numbers there are 24 numbers with distance 1 and 4 numbers with distance 2.

For 6-digit numbers in base 2 we have 8 fixed points. In base 10 notation the fixed points are (0_{10}) , (4_{10}) , (10_{10}) , (14_{10}) , (17_{10}) , (21_{10}) , (27_{10}) and (31_{10}) . Among the 56 other numbers there are 38 numbers with distance 1 and 18 numbers with distance 2.

For 7-digit numbers in base 2 we have 8 fixed points: (0_{10}) , (12_{10}) , (18_{10}) , (30_{10}) , (33_{10}) , (45_{10}) , (51_{10}) and (63_{10}) . Among the 120 other numbers there are 84 numbers with distance 1 and 36 numbers with distance 2.

For 8-digit numbers in base 2 we have 16 fixed points: (0_{10}) , (8_{10}) , (20_{10}) , (28_{10}) , (34_{10}) , (42_{10}) , (54_{10}) , (62_{10}) , (65_{10}) , (73_{10}) , (85_{10}) , (93_{10}) , (99_{10}) , (107_{10}) , (119_{10}) and (127_{10}) . Among the

240 other numbers there are 130 numbers with distance 1, 94 numbers with distance 2, 14 numbers with distance 3 and 2 numbers with distance 4.

For 9-digit numbers in base 2 we have 16 fixed points: (0_{10}) , (24_{10}) , (36_{10}) , (60_{10}) , (66_{10}) , (90_{10}) , (102_{10}) , (126_{10}) , (129_{10}) , (153_{10}) , (165_{10}) , (189_{10}) , (195_{10}) , (219_{10}) , (231_{10}) and (255_{10}) . Among the 496 other numbers there are 276 numbers with distance 1, 188 numbers with distance 2, 28 numbers with distance 3 and 4 numbers with distance 4.

Similar to the situation in base 10 we recognize in base 2 a similarity between a $(2k)$ -digit number and a $(2k + 1)$ -digit number. Also in base 2 we denote the frequency of m -digit numbers with distance D as $f_m(D)$. Then the similarity can be expressed as

$$f_{2k+1}(D) = \begin{cases} f_{2k}(D) & \text{if } D = 0 \\ 2f_{2k}(D) + f_{2k}(0) & \text{if } D = 1 \\ 2f_{2k}(D) & \text{if } D \geq 2. \end{cases} \quad (9.8)$$

and

$$\sum_{D=0}^{\infty} f_{2k+1}(D) = 2 \sum_{D=0}^{\infty} f_{2k}(D). \quad (9.9)$$

9.4 Digit reversal iteration in base 3

For 1-digit numbers in base 3 we have 3 orbits $0 \rightarrow 0$, $1 \rightarrow 0$ and $2 \rightarrow 0$. So, (0) is the single fixed point.

For 2-digit numbers in base 3 we have 9 orbits: $00 \rightarrow 00$, $01 \rightarrow 02 \rightarrow 11 \rightarrow 00$, $02 \rightarrow 11 \rightarrow 00$, $10 \rightarrow 02 \rightarrow 11 \rightarrow 00$ and $11 \rightarrow 00$, $12 \rightarrow 02 \rightarrow 11 \rightarrow 00$, $20 \rightarrow 11 \rightarrow 00$, $21 \rightarrow 02 \rightarrow 11 \rightarrow 00$, $22 \rightarrow 00$. Presented in base 10 it reads $0_{10} \rightarrow 0_{10}$, $1_{10} \rightarrow 2_{10} \rightarrow 4_{10} \rightarrow 0_{10}$, $2_{10} \rightarrow 4_{10} \rightarrow 0_{10}$, $3_{10} \rightarrow 2_{10} \rightarrow 4_{10} \rightarrow 0_{10}$ and $4_{10} \rightarrow 0_{10}$, $5_{10} \rightarrow 2_{10} \rightarrow 4_{10} \rightarrow 0_{10}$, $6_{10} \rightarrow 4_{10} \rightarrow 0_{10}$, $7_{10} \rightarrow 2_{10} \rightarrow 4_{10} \rightarrow 0_{10}$, $8_{10} \rightarrow 0_{10}$. So, (0_{10}) is a single fixed point.

For 2-digit numbers in base 3 the distance table is

distance	0	1	2	3	4	5	6	7	8	9
# n_0	1	2	2	4	0	0	0	0	0	0

Hereafter we will solely present the cycles and the distances. The distances will be presented in a distance table.

For 3-digit numbers in base 3 we have 1 fixed point: (0_{10}) . The distance table is

distance	0	1	2	3	4	5	6	7	8	9
# n_0	1	8	6	12	0	0	0	0	0	0

For 4-digit numbers in base 3 we have 2 fixed points: (0_{10}) and (32_{10}) . The distance table is

distance	0	1	2	3	4	5	6	7	8	9
# n_0	2	15	16	40	8	0	0	0	0	0

For 5-digit numbers in base 3 we have 2 fixed points: (0_{10}) and (104_{10}) . The distance table is

distance	0	1	2	3	4	5	6	7	8	9
# n_0	2	49	48	120	24	0	0	0	0	0

For 6-digit numbers in base 3 we have 3 fixed points: (0_{10}) , (96_{10}) , (320_{10}) , and 1 period 2 cycle: $(104_{10}, 520_{10})$. The distance table is

distance	0	1	2	3	4	5	6	7	8	9
# n_0	5	84	114	354	116	24	32	0	0	0

For 7-digit numbers in base 3 we have 3 fixed points: (0_{10}) , (312_{10}) and (968_{10}) , and one period 2 cycle: $(320_{10}, 1600_{10})$. The distance table is

distance	0	1	2	3	4	5	6	7	8	9
# n_0	5	262	342	1062	348	72	96	0	0	0

For 8-digit numbers in base 3 we have

5 fixed points: (0_{10}) , (288_{10}) , (960_{10}) , (2624_{10}) and (2912_{10}) ,

2 period 2 cycles: $(312_{10}, 1560_{10})$ and $(968_{10}, 4840_{10})$, and

1 period 4 cycle: $(320_{10}, 5440_{10}, 2240_{10}, 4160_{10})$.

The distance table is

distance	0	1	2	3	4	5	6	7	8	9
# n_0	13	496	760	2824	1176	476	488	128	88	16
distance	10	11	12	13	14	15	16	17	18	19
# n_0	16	80	0	0	0	0	0	0	0	0

For 9-digit numbers in base 3 we have

5 fixed points: (0_{10}) , (936_{10}) , (2904_{10}) , (7808_{10}) and (8744_{10}) ,

2 period 2 cycles: $(960_{10}, 4800_{10})$ and $(2912_{10}, 14560_{10})$, and

1 period 4 cycle: $(968_{10}, 16456_{10}, 6776_{10}, 12584_{10})$.

The distance table is

distance	0	1	2	3	4	5	6	7	8	9
# n_0	13	1514	2280	8472	3528	1428	1464	384	264	48
distance	10	11	12	13	14	15	16	17	18	19
# n_0	48	240	0	0	0	0	0	0	0	0

In base 3 the relation between distance frequencies of $2k + 1$ digit and $2k$ digit numbers is

$$f_{2k+1}(D) = \begin{cases} f_{2k}(D) & \text{if } D = 0 \\ 3f_{2k}(D) + 2f_{2k}(0) & \text{if } D = 1 \\ 3f_{2k}(D) & \text{if } D \geq 2 \end{cases} \quad (9.10)$$

and

$$\sum_{D=0}^{\infty} f_{2k+1}(D) = 3 \sum_{D=0}^{\infty} f_{2k}(D). \quad (9.11)$$

9.5 Digit reversal iteration in base b

In any base b the relation between distance frequencies of $2k + 1$ digit and $2k$ digit numbers is

$$f_{2k+1}(D) = \begin{cases} f_{2k}(D) & \text{if } D = 0 \\ bf_{2k}(D) + (b-1)f_{2k}(0) & \text{if } D = 1 \\ bf_{2k}(D) & \text{if } D \geq 2 \end{cases} \quad (9.12)$$

and

$$\sum_{D=0}^{\infty} f_{2k+1}(D) = b \sum_{D=0}^{\infty} f_{2k}(D). \quad (9.13)$$

For the remainder of the chapter we confine to the cycles.

9.6 Digit reversal iteration in base 4 through 9

For 1-digit numbers in base 4 we have a single fixed point: (0) .

For 2-digit numbers in base 4 we have

1 fixed point: (0) and

1 period 2 cycle: $(3_{10}, 9_{10})$.

For 3-digit numbers in base 4 we have

1 fixed point: (0) and

1 period 2 cycle: $(15_{10}, 45_{10})$.

For 4-digit numbers in base 4 we have

1 fixed point: (0) and

3 period 2 cycles: $(12_{10}, 36_{10})$, $(51_{10}, 153_{10})$ and $(63_{10}, 189_{10})$.

For 5-digit numbers in base 4 we have

1 fixed point: (0) and

3 period 2 cycles: $(60_{10}, 180_{10})$, $(195_{10}, 585_{10})$ and $(255_{10}, 765_{10})$.

For 6-digit numbers in base 4 we have

1 fixed point: (0) ,

7 period 2 cycles: $(48_{10}, 144_{10})$, $(204_{10}, 612_{10})$, $(252_{10}, 756_{10})$, $(771_{10}, 2313_{10})$,
 $(819_{10}, 2457_{10})$, $(975_{10}, 2925_{10})$ and $(1023_{10}, 3069_{10})$,

1 period 3 cycle: $(315_{10}, 3465_{10}, 1890_{10})$ and

1 period 6 cycle: $(615_{10}, 2865_{10}, 1635_{10}, 1590_{10}, 915_{10}, 2265_{10})$.

For 7-digit numbers in base 4 we have

1 fixed point: (0) ,

7 period 2 cycles: $(240_{10}, 720_{10})$, $(780_{10}, 2340_{10})$, $(1020_{10}, 3060_{10})$, $(3075_{10}, 9225_{10})$,
 $(3315_{10}, 9945_{10})$, $(3855_{10}, 11565_{10})$ and $(4095_{10}, 12285_{10})$,

1 period 3 cycle: $(1275_{10}, 14025_{10}, 7650_{10})$ and

1 period 6 cycle: $(2535_{10}, 11505_{10}, 6435_{10}, 6390_{10}, 3795_{10}, 8985_{10})$.

For 8-digit numbers in base 4 we have

1 fixed point: (0) ,

15 period 2 cycles: $(192_{10}, 576_{10})$, $(816_{10}, 2448_{10})$, $(1008_{10}, 3024_{10})$, $(3084_{10}, 9252_{10})$,
 $(3276_{10}, 9828_{10})$, $(3900_{10}, 11700_{10})$, $(4092_{10}, 12276_{10})$, $(12483_{10}, 37449_{10})$,
 $(13299_{10}, 39897_{10})$, $(15375_{10}, 46125_{10})$, $(16383_{10}, 49149_{10})$, $(12291_{10}, 36873_{10})$,
 $(13107_{10}, 39321_{10})$, $(15567_{10}, 46701_{10})$ and $(16191_{10}, 48573_{10})$,

2 period 3 cycles: $(1260_{10}, 13860_{10}, 7560_{10})$ and $(5115_{10}, 56265_{10}, 30690_{10})$,

1 period 5 cycle: $(6375_{10}, 49725_{10}, 17850_{10}, 26775_{10}, 28050_{10})$,

2 period 6 cycles: $(2460_{10}, 11460_{10}, 6540_{10}, 6360_{10}, 3660_{10}, 9060_{10})$ and

$(10215_{10}, 46065_{10}, 25635_{10}, 25590_{10}, 15315_{10}, 35865_{10})$.

For 9-digit numbers in base 4 we have

1 fixed point: (0) ,

15 period 2 cycles: $(960_{10}, 2880_{10})$, $(3120_{10}, 9360_{10})$, $(4080_{10}, 12240_{10})$,

$(12300_{10}, 36900_{10})$, $(13260_{10}, 39780_{10})$, $(15420_{10}, 46260_{10})$, $(16380_{10}, 49140_{10})$,

$(49155_{10}, 147465_{10})$, $(50115_{10}, 150345_{10})$, $(52275_{10}, 156825_{10})$, $(53235_{10}, 159705_{10})$,

$(61455_{10}, 184365_{10})$, $(62415_{10}, 187245_{10})$, $(64575_{10}, 193725_{10})$ and $(65535_{10}, 196605_{10})$,

2 period 3 cycles: $(5100_{10}, 56100_{10}, 30600_{10})$ and $(20475_{10}, 225225_{10}, 122850_{10})$,

1 period 5 cycle: $(25575_{10}, 199485_{10}, 71610_{10}, 107415_{10}, 112530_{10})$,

2 period 6 cycles: $(10140_{10}, 46020_{10}, 25740_{10}, 25560_{10}, 15180_{10}, 35940_{10})$ and

$(40935_{10}, 184305_{10}, 102435_{10}, 102390_{10}, 61395_{10}, 143385_{10})$.

For 1-digit numbers in base 5 we have 1 fixed point: (0) .

For 2-digit numbers in base 5 we have 2 fixed points: (0) and (8_{10}) .

For 3-digit numbers in base 5 we have 2 fixed points: (0) and (48_{10}) .

For 4-digit numbers in base 5 we have

4 fixed points: (0) , (40_{10}) , (208_{10}) and (248_{10}) , and

1 period 2 cycle: $(144, 432)$.

For 5-digit numbers in base 5 we have

4 fixed points: (0) , (240_{10}) , (1008_{10}) , (1248_{10}) , and

1 period 2 cycle: $(744, 2232)$.

For 6-digit numbers in base 5 we have

8 fixed points: (0) , (200_{10}) , (1040_{10}) , (1240_{10}) , (5008_{10}) , (5208_{10}) , (6048_{10}) and (6248_{10}) ,

2 period 2 cycles: $(720_{10}, 2160_{10})$ and $(3744_{10}, 11232_{10})$, and

1 period 3 cycle: $(744_{10}, 14136_{10}, 9672_{10})$.

For 7-digit numbers in base 5 we have

8 fixed points: (0) , (1200_{10}) , (5040_{10}) , (6240_{10}) , (25008_{10}) , (26208_{10}) , (30048_{10}) and (31248_{10}) , and

2 period 2 cycles: $(3720_{10}, 11160_{10})$ and $(18744_{10}, 56232_{10})$, and

1 period 3 cycle: $(3744_{10}, 7136_{10}, 48672_{10})$.

For 8-digit numbers in base 5 we have

16 fixed points: (0) , (1000_{10}) , (5200_{10}) , (6200_{10}) , (25040_{10}) , (26040_{10}) , (30240_{10}) ,

(31240_{10}) , (125008_{10}) , (126008_{10}) , (130208_{10}) , (131208_{10}) , (150048_{10}) , (151048_{10}) ,

(155248_{10}) and (156248_{10}) , and

4 period 2 cycles: $(3600_{10}, 10800_{10})$, $(18720_{10}, 56160_{10})$, $(90144_{10}, 270432_{10})$ and

$(93744_{10}, 281232_{10})$, and

3 period 3 cycles: $(3720_{10}, 70680_{10}, 48360_{10})$, $(41184_{10}, 295776_{10}, 213408_{10})$ and

$(18744_{10}, 356136_{10}, 243672_{10})$.

For 9-digit numbers in base 5 we have

16 fixed points: (0) , (6000_{10}) , (25200_{10}) , (31200_{10}) , (125040_{10}) , (131040_{10}) ,
 (150240_{10}) , (156240_{10}) , (625008_{10}) , (631008_{10}) , (650208_{10}) , (656208_{10}) ,
 (750048_{10}) , (756048_{10}) , (775248_{10}) and (781248_{10}) , and

4 period 2 cycles: $(18600_{10}, 55800_{10})$, $(93720_{10}, 281160_{10})$, $(450144_{10}, 1350432_{10})$ and
 $(468744_{10}, 1406232_{10})$, and

3 period 3 cycles: $(18720_{10}, 355680_{10}, 243360_{10})$, $(206184_{10}, 1480776_{10}, 1068408_{10})$ and
 $(93744_{10}, 1781136_{10}, 1218672_{10})$.

For both 10-digit and 11-digit numbers in base 5 we have 32 fixed points, 7 period 2 cycles, 5 period 3 cycles and 1 period 11 cycle.

For 1-digit numbers in base 6 we have 1 fixed point: (0) .

For 2-digit numbers in base 6 we have 1 fixed point: (0) and 1 period 3 cycle: $(5_{10}, 25_{10}, 15_{10})$.

For 3-digit numbers in base 6 we have

1 fixed point: (0) and 1 period 3 cycle: $(35_{10}, 175_{10}, 105_{10})$.

For 4-digit numbers in base 6 we have

2 fixed points: (0) and (490_{10}) , and

3 period 3 cycles: $(30_{10}, 150_{10}, 90_{10})$, $(215_{10}, 1075_{10}, 645_{10})$ and $(185_{10}, 925_{10}, 555_{10})$.

For 5-digit numbers in base 6 we have

2 fixed points: (0) and (3010_{10}) , and

3 period 3 cycles: $(210_{10}, 1050_{10}, 630_{10})$, $(1295_{10}, 6475_{10}, 3885_{10})$, $(1085_{10}, 5425_{10}, 3255_{10})$.

For 6-digit and 7-digit numbers in base 6 we have 3 fixed points, 7 period 3 cycles,

1 period 5 cycle and 1 period 12 cycle.

For 8-digit and 9-digit numbers in base 6 we have 5 fixed points, 15 period 3 cycles,

2 period 5 cycles, 1 period 6 cycle and 2 period 12 cycles.

For 1-digit numbers in base 7 we have 1 fixed point: (0) .

For 2-digit numbers in base 7 we have 1 fixed point: (0) .

For 3-digit numbers in base 7 we have 1 fixed point: (0) .

For 4-digit numbers in base 7 we have

1 fixed point: (0) and

1 period 3 cycle: $(384_{10}, 1920_{10}, 1152_{10})$.

For 5-digit numbers in base 7 we have

1 fixed point: (0) and

1 period 3 cycle: $(2736_{10}, 13680_{10}, 8208_{10})$.

For 6-digit numbers in base 7 we have

1 fixed point: (0) and

2 period 3 cycles: $(2688_{10}, 13440_{10}, 8064_{10})$ and $(19200_{10}, 96000_{10}, 57600_{10})$ and

1 period 6 cycle: $(2736_{10}, 112176_{10}, 90288_{10}, 46512_{10}, 24624_{10}, 68400_{10})$.

For 7-digit numbers in base 7 we have

1 fixed point: (0) and

2 period 3 cycles: $(19152_{10}, 95760_{10}, 57456_{10})$ and $(134448_{10}, 672240_{10}, 403344_{10})$ and

1 period 6 cycle: $(19200_{10}, 787200_{10}, 633600_{10}, 326400_{10}, 172800_{10}, 480000_{10})$.

For 8-digit and 9-digit numbers in base 7 we have 1 fixed point, 4 period 3 cycles and 2 period 6 cycles.

For 1-digit numbers in base 8 we have 1 fixed point: (0) .

For 2-digit numbers in base 8 we have

2 fixed points: (0) and (21_{10}) , and

1 period 3 cycle: $(7_{10}, 49_{10}, 35_{10})$.

For 3-digit numbers in base 8 we have

2 fixed points: (0) and (189_{10}) , and

1 period 3 cycle: $(63_{10}, 441_{10}, 315_{10})$.

For 4-digit numbers in base 8 we have

4 fixed points: (0) , (168_{10}) , (1365_{10}) and (1533_{10}) and

3 period 3 cycles: $(56_{10}, 392_{10}, 280_{10})$, $(455_{10}, 3185_{10}, 2275_{10})$ and $(511_{10}, 3577_{10}, 2555_{10})$.

For 5-digit numbers in base 8 we have

4 fixed points: (0) , (1512_{10}) , (10773_{10}) , (12285_{10}) and

3 period 3 cycles: $(4095_{10}, 28665_{10}, 20475_{10})$, $(504_{10}, 3528_{10}, 2520_{10})$ and $(3591_{10}, 25137_{10}, 17955_{10})$.

For 6-digit and 7-digit numbers in base 8 we have 8 fixed points, 1 period 2 cycle,

7 period 3 cycles, 1 period 4 cycle and 7 period 8 cycles.

For 8-digit and 9-digit numbers in base 8 we have 16 fixed points, 2 period 2 cycle,

15 period 3 cycles, 2 period 4 cycles, 5 period 7 cycles, 14 period 8 cycles and 2 period 14 cycles.

For 1-digit numbers in base 9 we have 1 fixed point: (0) .

For 2-digit numbers in base 9 we have

1 fixed point: (0) , and

1 period 2 cycle: $(16_{10}, 48_{10})$.

For 3-digit numbers in base 9 we have

1 fixed point: (0) , and

1 period 2 cycle: $(160_{10}, 480_{10})$.

For 4-digit numbers in base 9 we have

2 fixed points: (0) and (2400_{10}) , and

3 period 2 cycles: $(144_{10}, 432_{10})$, $(1312, 3936_{10})$ and $(1456_{10}, 4368_{10})$, and

1 period 3 cycle: $(800_{10}, 5600_{10}, 4000_{10})$, and

1 period 4 cycle: $(224_{10}, 6112_{10}, 5024_{10}, 3488_{10})$.

For 5-digit numbers in base 9 we have

2 fixed points: (0) and (21840_{10}) , and

3 period 2 cycles: $(1440_{10}, 4320_{10})$, $(11680_{10}, 35040_{10})$ and $(13120_{10}, 39360_{10})$, and

1 period 3 cycle: $(7280_{10}, 50960_{10}, 36400_{10})$, and

1 period 4 cycle: $(1520_{10}, 55360_{10}, 45200_{10}, 32000_{10})$.

For 6-digit and 7-digit numbers in base 9 we have 3 fixed points, 7 period 2 cycle,

2 period 3 cycles, 4 period 4 cycle and 2 period 8 cycles.

For 8-digit and 9-digit numbers in base 9 we have 5 fixed points, 15 period 2 cycle,

5 period 3 cycles, 8 period 4 cycle, 4 period 6 cycles and 4 period 8 cycles.

9.7 Periodic cycles

For instance for 9-digit numbers in base 3 we found 5 fixed points and 2 period 2 cycle and 1 period 4 cycle. It will be denote briefly as $1_5, 2_2, 4$. With this notation the fixed points and period cycles for 1- through 10-digit numbers in base 2 through 10 are tabulated below.

base \ digits	2	3	4	5	6	7
1	1	1	1	1	1	1
2	1_2	1	1, 2	1_2	1, 3	1
3	1_2	1	1, 2	1_2	1, 3	1
4	1_4	1_2	1, 2_3	$1_4, 2$	$1_2, 3_3$	1, 3
5	1_4	1_2	1, 2_3	$1_4, 2$	$1_2, 3_3$	1, 3
6	1_8	$1_3, 2$	1, $2_7, 3, 6$	$1_8, 2_2, 3$	$1_3, 3_7, 5, 12$	1, $3_2, 6$
7	1_8	$1_3, 2$	1, $2_7, 3, 6$	$1_8, 2_2, 3$	$1_3, 3_7, 5, 12$	1, $3_2, 6$
8	1_{16}	$1_5, 2_2, 4$	1, $2_{15}, 3_2, 5, 6_2$	$1_{16}, 2_4, 3_3$	$1_5, 3_{15}, 5_2, 12_2$	1, $3_4, 6_2$
9	1_{16}	$1_5, 2_2, 4$	1, $2_{15}, 3_2, 5, 6_2$	$1_{16}, 2_4, 3_3$	$1_5, 3_{15}, 5_2, 12_2$	1, $3_4, 6_2$

base \ digits	8	9	10
1	1	1	1
2	1 ₂ , 3	1, 2	1, 5
3	1 ₂ , 3	1, 2	1, 5
4	1 ₄ , 3 ₃	1 ₂ , 2 ₃ , 3, 4	1, 2, 5 ₃
5	1 ₄ , 3 ₃	1 ₂ , 2 ₃ , 3, 4	1, 2, 5 ₃
6	1 ₈ , 3 ₇ , 4, 8 ₇	1 ₃ , 2 ₇ , 3 ₂ , 4 ₄ , 8 ₂	1, 2 ₂ , 5 ₇ , 9, 18
7	1 ₈ , 3 ₇ , 4, 8 ₇	1 ₃ , 2 ₇ , 3 ₂ , 4 ₄ , 8 ₂	1, 2 ₂ , 5 ₇ , 9, 18
8	1 ₁₆ , 2 ₂ , 3 ₁₅ , 4 ₂ , 7 ₅ , 8 ₁₄ , 14 ₂	1 ₅ , 2 ₁₅ , 3 ₅ , 4 ₈ , 6 ₄ , 8 ₄	1, 2 ₄ , 5 ₁₅ , 9 ₂ , 14, 18 ₂
9	1 ₁₆ , 2 ₂ , 3 ₁₅ , 4 ₂ , 7 ₅ , 8 ₁₄ , 14 ₂	1 ₅ , 2 ₁₅ , 3 ₅ , 4 ₈ , 6 ₄ , 8 ₄	1, 2 ₄ , 5 ₁₅ , 9 ₂ , 14, 18 ₂

Chapter 10

Kaprekar

10.1 Kaprekar's constant

For 4-digit numbers we consider the following iteration:

$$n_{k+1} = \delta(n_k) - \alpha(n_k), \quad (10.1)$$

where $\delta(n_k)$ is created by sorting the 4 digits of n_k in descending order and $\alpha(n_k)$ is created by sorting the 4 digits of n_k in ascending order. For the algorithm numbers smaller than 1000 are preceded by zero's to make them 4-digit numbers: $123 \rightarrow 0123$, $64 \rightarrow 0064$, $7 \rightarrow 0007$, etc.

For the 4-digit number $n_0 = 9271$ we obtain $\delta(9271) = 9721$, $\alpha(9271) = 1279$ and

$n_1 = 9721 - 1279 = 8442$. Repeating the iteration we obtain

$$n_2 = 8442 - 2448 = 5994,$$

$$n_3 = 9954 - 4599 = 5355,$$

$$n_4 = 5553 - 3555 = 1998,$$

$$n_5 = 9981 - 1899 = 8082,$$

$$n_6 = 8820 - 0288 = 8532,$$

$$n_7 = 8532 - 2358 = 6174,$$

$$n_8 = 7641 - 1467 = 6174.$$

That is, 6174 is a fixed point.

When applied to $n_0 = 0123$ we successively obtain

$$n_1 = 3210 - 0123 = 3087,$$

$$n_2 = 8730 - 0378 = 8352,$$

$$n_3 = 8532 - 2358 = 6174$$

$$n_4 = 7641 - 1467 = 6174.$$

It turns out that the orbit for almost all 4-digit numbers ends in the fixed point (6174). The only exceptions are the 10 numbers 0000, 1111, 2222, ..., 9999 which are mapped to the fixed point (0000).

The number 6174 is known as *Kaprekar's constant*.

As before we let the distance be the number of steps required to reach a period cycle. For 4-digit numbers the distance is the number of steps required to arrive at one of the fixed points (0000) and (6174). The distance table is

distance	0	1	2	3	4	5	6	7	8	9
# n_0	2	392	576	2400	1272	1518	1656	2184	0	0

Since we did not recognize a relation between distance tables, the distance tables will be left in the remainder of this chapter.

There are two ways to generalize the iteration. The first way is by considering numbers with other than 4 digits. The second way is by considering numbers in other bases. We start with considering numbers with m digits in base 10.

10.2 Kaprekar for m -digit numbers

For m -digit numbers the Kaprekar iteration is given by

$$n_{k+1} = \delta(n_k) - \alpha(n_k), \quad (10.2)$$

where $\delta(n_k)$ is created by sorting the m digits of n_k in descending order and $\alpha(n_k)$ is created by sorting the m digits of n_k in ascending order. Numbers smaller than 10^m are preceded by zero's to make them m -digit numbers.

For 1-digit numbers and 2-digit numbers the Kaprekar iteration is identical to the digit reversal iteration.

The 3-digit numbers 000, 111, 222, ..., 999 are mapped to the fixed point (000). For all other 3-digit numbers the orbit arrives at the fixed point (495). In order to see this we let $d_2 \geq d_1 \geq d_0$ be the digits of a descending ordered number n_0 . That is, $\delta(n_0) = 100d_2 + 10d_1 + d_0$. If $d_2 = d_0$ then $n_1 = 000$ else $n_1 = 100(d_2 - d_0) + 10(d_1 - d_1) + (d_0 - d_2) = 99(d_2 - d_0)$. In the latter case the nine possibilities for the successive orbits are

$$\begin{aligned} 99 \cdot 1 &= 099 \rightarrow 891 \rightarrow 792 \rightarrow 693 \rightarrow 594 \rightarrow 495 \quad , \\ 99 \cdot 2 &= 198 \rightarrow 792 \rightarrow 693 \rightarrow 594 \rightarrow 495 \quad , \\ 99 \cdot 3 &= 297 \rightarrow 693 \rightarrow 594 \rightarrow 495 \quad , \\ 99 \cdot 4 &= 396 \rightarrow 594 \rightarrow 495 \quad , \end{aligned}$$

$$99 \cdot 5 = 495 \rightarrow 495 \quad ,$$

$$99 \cdot 6 = 594 \rightarrow 495 \quad ,$$

$$99 \cdot 7 = 693 \rightarrow 594 \rightarrow 495 \quad ,$$

$$99 \cdot 8 = 792 \rightarrow 693 \rightarrow 594 \rightarrow 495 \quad ,$$

$99 \cdot 9 = 891 \rightarrow 792 \rightarrow 693 \rightarrow 594 \rightarrow 495$. That is, for 3-digit numbers the orbit arrives at the fixed point (000) or the fixed point (495) in 5 or less steps.

For $m = 4$ there are two fixed points: (0000) and (6174). For 4-digit numbers the orbit arrives at the fixed point (0000) or the fixed point (6174) in 7 or less steps.

For $m = 5$ we have

one fixed point: (00000),

one period 2 cycle: (53955, 59994), and

two period 4 cycles: (61974, 82962, 75933, 63954) and (62964, 71973, 83952, 74943).

For $m = 6$ we have

three fixed points: (000000), (549945), (631764), and

one period 7 cycle: (420876, 851742, 750843, 840852, 860832, 862632, 642654).

For $m = 7$ we have

one fixed point: (0000000), and

one period 8 cycle: (7509843, 9529641, 8719722, 8649432, 7519743, 8429652, 7619733, 8439552).

For $m = 8$ we have

three fixed points: (00000000), (63317664), (97508421),

one period 3 cycle: (64308654, 83208762, 86526432), and

one period 7 cycle: (43208766, 85317642, 75308643, 84308652, 86308632, 86326632, 64326654).

For $m = 9$ we have

three fixed points: (000000000), (554999445), (864197532), and

one period 14 cycle: (753098643, 954197541, 883098612, 976494321, 874197522, 865296432, 763197633, 844296552, 762098733, 964395531, 863098632, 965296431, 873197622, 865395432).

For $m = 10$ we have

four fixed points: (0000000000), (6333176664), (9753086421), (9975084201),

four period 3 cycles:

(6431088654, 8732087622, 8655264432),
 (6433086654, 8332087662, 8653266432),
 (6543086544, 8321088762, 8765264322),
 (9751088421, 9775084221, 9755084421), and
 one period 7 cycle: (4332087666, 8533176642, 7533086643, 8433086652, 8633086632,
 8633266632, 6433266654).

For $m = 11$ we have

two fixed points: (0000000000), (86431976532),
 one period 5 cycle: (86420987532, 96641975331, 88431976512, 87641975322,
 86541975432), and
 one period 8 cycle: (76320987633, 96442965531, 87320987622, 96653954331,
 86330986632, 96532966431, 87331976622, 86542965432).

For $m = 12$ we have

eight fixed points: (000000000000), (555499994445), (633331766664),
 (975330866421), (977750842221), (997530864201), (997750842201), (999750842001),
 eight period 3 cycles:
 (643110888654, 877320876222, 865552644432),
 (643310886654, 873320876622, 865532664432),
 (643330866654, 833320876662, 865332666432),
 (654310886544, 873210887622, 876552644322),
 (654330866544, 833210887662, 876532664322),
 (655430865444, 832110888762, 877652643222),
 (975310886421, 977530864221, 975530864421)
 (975510884421, 977510884221, 977550844221), and
 one period 7 cycle: (433320876666, 853331766642, 753330866643,
 843330866652, 863330866632, 863332666632, 643332666654).

10.3 Kaprekar in base 2

For 1-digit numbers in base 2 we have two orbits: $0 \rightarrow 0$ and $1 \rightarrow 0$. That is, (0) is the single fixed point.

For 2-digit numbers in base 2 we have four different starting values with orbits: $00 \rightarrow 00$, $01 \rightarrow 01$, $10 \rightarrow 01$ and $11 \rightarrow 00$. That is, (00) and (01) are fixed points. The numbers 10 and 11 both have distance 1.

For 3-digit numbers in base 2 we have: $000 \rightarrow 000$, $001 \rightarrow 011$, $010 \rightarrow 000$, $011 \rightarrow 011$,

$100 \rightarrow 011$, $101 \rightarrow 000$, $110 \rightarrow 011$, $111 \rightarrow 000$. That is, (000) and $(011) = (3_{10})$ are fixed points. The 6 other numbers have distance 1.

For 4-digit numbers in base 2 we have 3 fixed points: (0000) , $(0111) = (7_{10})$ and $(1001) = (9_{10})$. The 13 other numbers have distance 1.

For 5-digit numbers in base 2 we have 3 fixed points: (00000) , $(01111) = (15_{10})$ and $(10101) = (21_{10})$. The 29 other numbers have distance 1.

For 6-digit numbers in base 2 we have 4 fixed points: (000000) , $(011111) = (31_{10})$, $(101101) = (45_{10})$ and $(110001) = (49_{10})$. The 60 other numbers have distance 1.

For 7-digit numbers in base 2 we have 4 fixed points: (0000000) , $(0111111) = (63_{10})$, $(1011101) = (93_{10})$ and $(1101001) = (105_{10})$. The 124 other numbers have distance 1.

For 8-digit numbers in base 2 we have 5 fixed points: (00000000) , $(01111111) = (127_{10})$, $(10111101) = (189_{10})$, $(11011001) = (217_{10})$ and $(11100001) = (225_{10})$. The 251 other numbers have distance 1.

For 9-digit numbers in base 2 we have 5 fixed points: (000000000) , $(011111111) = (255_{10})$, $(101111101) = (381_{10})$, $(110111001) = (441_{10})$ and $(111010001) = (465_{10})$. The 507 other numbers have distance 1.

For 10-digit numbers in base 2 we have 6 fixed points: (0000000000) , $(0111111111) = (511_{10})$, $(1011111101) = (765_{10})$, $(1101111001) = (889_{10})$, $(1110110001) = (945_{10})$ and $(1111000001) = (961_{10})$. The 1018 other numbers have distance 1.

For 11-digit numbers in base 2 we have 6 fixed points: (00000000000) , $(01111111111) = (1023_{10})$, $(10111111101) = (1533_{10})$, $(11011111001) = (1785_{10})$, $(11101110001) = (1905_{10})$ and $(11110100001) = (1953_{10})$. The 2042 other numbers have distance 1.

For 12-digit numbers in base 2 we have 7 fixed points: (000000000000) , $(011111111111) = (2047_{10})$, $(101111111101) = (3069_{10})$, $(110111111001) = (3577_{10})$, $(111011110001) = (3825_{10})$, $(111101100001) = (3937_{10})$ and $(111110000001) = (3969_{10})$. The 4089 other numbers have distance 1.

We recognize a pattern: for m -digit numbers the values of the fixed points are $2^m - 2^{m-k} - 2^k + 1$ where k is an integer, $0 \leq k \leq \lfloor m/2 \rfloor$. This can be understood as follows. Let a m -digit number n_0 in base 2 have k digits equal to 0 and $m-k$ digits equal to 1. Therefore, $\delta(n_0) = 2^m - 2^k$

is in base 2 a number with $m - k$ one's to the left and k zero's to the right. Explicitly,

$$\begin{array}{|c|c|c|c|c|c|c|c|c|c|c|} \hline 1 & 1 & \dots & 1 & 1 & 0 & 0 & \dots & 0 & 0 & 0 \\ \hline m-1 & m-2 & \dots & k+1 & k & k-1 & k-2 & \dots & 2 & 1 & 0 \\ \hline \end{array}$$

Subtraction of $\alpha(n_0) = 2^{m-k} - 1$ from $\delta(n_0)$ gives $n_1 = \delta(n_0) - \alpha(n_0) = 2^m - 2^k - 2^{m-k} + 1$. For $0 \leq k \leq \lfloor m/2 \rfloor$ the subtraction of 2^{m-k} from $2^m - 2^k$ just changes a 1 into a 0, while the addition by 1 changes the last digit from 0 to 1. As a net result, $n_1 = 2^m - 2^k - 2^{m-k} + 1$ will have as many one's as $2^m - 2^k$ and thus as n_0 . As a consequence, $n_2 = n_1$ and thus is n_1 a fixed point.

10.4 Kaprekar in base 3 through 9

For 1-digit numbers in base 3 we have three orbits $0 \rightarrow 0$, $1 \rightarrow 0$ and $2 \rightarrow 0$. So, (0) is the single fixed point.

For 2-digit numbers in base 3 we have nine orbits: $00 \rightarrow 00$, $01 \rightarrow 02 \rightarrow 11 \rightarrow 00$, $02 \rightarrow 11 \rightarrow 00$, $10 \rightarrow 02 \rightarrow 11 \rightarrow 00$ and $11 \rightarrow 00$, $12 \rightarrow 02 \rightarrow 11 \rightarrow 00$, $20 \rightarrow 11 \rightarrow 00$, $21 \rightarrow 02 \rightarrow 11 \rightarrow 00$, $22 \rightarrow 00$. That is, (00) is the single fixed point.

For 3-digit numbers in base 3 we have

one fixed point: (000) and

one period 2 cycle: $(022, 121) = (8_{10}, 16_{10})$.

For 4-digit numbers in base 3 we have

one fixed point: (0_{10}) and

one period 2 cycle: $(32_{10}, 52_{10})$.

For 5-digit numbers in base 3 we have two fixed points: (0_{10}) , (184_{10}) .

For 6-digit numbers in base 3 we have

one fixed point: (0_{10}) and

one period 3 cycle: $(320_{10}, 580_{10}, 484_{10})$.

For 7-digit numbers in base 3 we have

two fixed points: (0_{10}) , (2008_{10}) and

one period 2 cycle: $(1696_{10}, 1768_{10})$.

For 8-digit numbers in base 3 we have two fixed points: (0_{10}) and (5332_{10}) .

For 9-digit numbers in base 3 we have

two fixed points: (0_{10}) , (19144_{10}) ,

one period 2 cycle: $(18208_{10}, 18424_{10})$ and

one period 3 cycle: $(15304_{10}, 16024_{10}, 16240_{10})$.

For 10-digit numbers in base 3 we have

two fixed points: (0_{10}) , (55360_{10}) and

one period 4 cycle: $(26240_{10}, 48100_{10}, 48964_{10}, 39364_{10})$.

For 11-digit numbers in base 3 we have

three fixed points: (0_{10}) , (146488_{10}) , (175528_{10}) ,
 one period 2 cycle: $(172720_{10}, 173368_{10})$, and
 two period 3 cycles: $(137776_{10}, 144328_{10}, 147136_{10})$, $(164008_{10}, 166168_{10}, 166816_{10})$.

For 12-digit numbers in base 3 we have

two fixed points: (0_{10}) , (520372_{10}) and
 one period 2 cycle: $(433012_{10}, 441652_{10})$.

For base 4 through 9 we will not give the values of the cycle members, except for the fixed points.

For 1-digit numbers in base 4 we have 1 fixed point: (0_{10}) .

For 2-digit numbers in base 4 we have 1 fixed point: (0_{10}) , and 1 period 2 cycle.

For 3-digit numbers in base 4 we have 2 fixed points: (0_{10}) and (30_{10}) .

For 4-digit numbers in base 4 we have 2 fixed points: (0_{10}) and (201_{10}) , and 1 period 2 cycle.

For 5-digit numbers in base 4 we have 1 fixed point: (0_{10}) , and 1 period 2 cycle.

For 6-digit numbers in base 4 we have 4 fixed points: (0_{10}) , (2550_{10}) , (3369_{10}) and (3873_{10}) .

For 7-digit numbers in base 4 we have 2 fixed points: (0_{10}) and (14565_{10}) .

For 8-digit numbers in base 4 we have 4 fixed points: (0_{10}) , (54441_{10}) , (62625_{10}) and (64641_{10}) ,
 and 1 period 3 cycle.

For 9-digit numbers in base 4 we have 4 fixed points: (0_{10}) , (234405_{10}) , (171990_{10}) and
 (254865_{10}) .

For 10-digit numbers in base 4 we have 6 fixed points: (0_{10}) , (873129_{10}) , (954261_{10}) ,
 (1004193_{10}) , (1036929_{10}) and (1044993_{10}) , and 1 period 2 cycle.

For 11-digit numbers in base 4 we have 4 fixed points: (0_{10}) , (3755685_{10}) , (4083345_{10}) and
 (4165185_{10}) , and 1 period 3 cycle.

For 12-digit numbers in base 4 we have 9 fixed points: (0_{10}) , (11140950_{10}) , (13978281_{10}) ,
 (15285909_{10}) , (16075425_{10}) , (16399953_{10}) , (16599681_{10}) , (16730625_{10}) , (16762881_{10}) .

For 1-digit numbers in base 5 we have 1 fixed point: (0_{10}) .

For 2-digit numbers in base 5 we have 2 fixed points: (0_{10}) and (8_{10}) .

For 3-digit numbers in base 5 we have 1 fixed point: (0_{10}) , and 1 period 2 cycle.

For 4-digit numbers in base 5 we have 2 fixed points: (0_{10}) and (392_{10}) .

For 5-digit numbers in base 5 we have 1 fixed point: (0_{10}) , and 1 period 4 cycle.

For 6-digit numbers in base 5 we have 1 fixed point: (0_{10}) , and 1 period 5 cycle.

For 7-digit numbers in base 5 we have 1 fixed point: (0_{10}) , and 1 period 4 cycle.

For 8-digit numbers in base 5 we have 1 fixed point: (0_{10}) , and 1 period 6 cycle.

For 9-digit numbers in base 5 we have 2 fixed points: (0_{10}) and (1831056_{10}) .

For 10-digit numbers in base 5 we have 1 fixed point: (0_{10}) , and 1 period 4 cycle.

For 11-digit numbers in base 5 we have 2 fixed points: (0_{10}) and (48217776_{10}) , and 1 period

3 cycle.

For 12-digit numbers in base 5 we have 1 fixed point: (0_{10}) , and 1 period 8 cycle.

For 1-digit numbers in base 6 we have 1 fixed point: (0_{10}) .

For 2-digit numbers in base 6 we have 1 fixed point: (0_{10}) , and 1 period 3 cycle.

For 3-digit numbers in base 6 we have 2 fixed points: (0_{10}) and (105_{10}) .

For 4-digit numbers in base 6 we have 1 fixed point: (0_{10}) , and 1 period 6 cycle.

For 5-digit numbers in base 6 we have 2 fixed points: (0_{10}) and (5600_{10}) , and 1 period 2 cycle.

For 6-digit numbers in base 6 we have 4 fixed points: (0_{10}) , (27195_{10}) , (33860_{10}) and (42925_{10}) , and 1 period 3 cycle.

For 7-digit numbers in base 6 we have 1 fixed point: (0_{10}) , and 1 period 2 cycle.

For 8-digit numbers in base 6 we have 3 fixed points: (0_{10}) , (1275170_{10}) and (1657225_{10}) , and 2 period 2 cycles and 1 period 7 cycle.

For 9-digit numbers in base 6 we have 2 fixed points: (0_{10}) and (6018495_{10}) , and 1 period 2 cycle.

For 10-digit numbers in base 6 we have 5 fixed points: (0_{10}) , (45962330_{10}) , (47681900_{10}) , (56319925_{10}) and (60331825) , and 3 period 2 cycles.

For 11-digit numbers in base 6 we have 3 fixed points: (0_{10}) , (277695950_{10}) and (348285175_{10}) , and 1 period 2 cycle.

For 12-digit numbers in base 6 we have 4 fixed points: (0_{10}) , (1305060855_{10}) , (2151904825_{10}) and (2175976225_{10}) , and 6 period 2 cycles.

For 1-digit numbers in base 7 we have 1 fixed point: (0_{10}) .

For 2-digit numbers in base 7 we have 1 fixed point: (0_{10}) .

For 3-digit numbers in base 7 we have 1 fixed point: (0_{10}) , and 1 period 2 cycle.

For 4-digit numbers in base 7 we have 1 fixed point: (0_{10}) , and 1 period 3 cycle.

For 5-digit numbers in base 7 we have 1 fixed point: (0_{10}) , and 1 period 5 cycle.

For 6-digit numbers in base 7 we have 1 fixed point: (0_{10}) , and 1 period 6 cycle.

For 7-digit numbers in base 7 we have 1 fixed point: (0_{10}) , and 1 period 6 cycle.

For 8-digit numbers in base 7 we have 1 fixed point: (0_{10}) , and 1 period 6 cycle.

For 9-digit numbers in base 7 we have 1 fixed point: (0_{10}) , and 1 period 11 cycle.

For 10-digit numbers in base 7 we have 1 fixed point: (0_{10}) , and 3 period 2 cycles.

For 11-digit numbers in base 7 we have 2 fixed points: (0_{10}) and (1922263344_{10}) .

For 12-digit numbers in base 7 we have 2 fixed points: (0_{10}) and (11150766552_{10}) , and 1 period 5 cycle.

For 1-digit numbers in base 8 we have 1 fixed point: (0_{10}) .

For 2-digit numbers in base 8 we have 2 fixed points: (0_{10}) and (21_{10}) , and 1 period 3 cycle.

For 3-digit numbers in base 8 we have 2 fixed points: (0_{10}) and (252_{10}) .

For 4-digit numbers in base 8 we have 1 fixed point: (0_{10}) , and 1 period 3 cycle and 1 period 5 cycle.

For 5-digit numbers in base 8 we have 1 fixed point: (0_{10}) , and 1 period 2 cycle and 1 period 4 cycle.

For 6-digit numbers in base 8 we have 3 fixed points: (0_{10}) , (147420_{10}) and (213402_{10}) , and 1 period 3 cycle.

For 7-digit numbers in base 8 we have 2 fixed points: (0_{10}) and (1711962_{10}) , and 1 period 4 cycle and 1 period 7 cycle.

For 8-digit numbers in base 8 we have 2 fixed points: (0_{10}) and (16092433_{10}) , and 2 period 3 cycles.

For 9-digit numbers in base 8 we have 2 fixed points: (0_{10}) and (76545756_{10}) , 1 period 4 cycle, and 2 period 5 cycles.

For 10-digit numbers in base 8 we have 2 fixed points: (0_{10}) and (1068263553_{10}) , and 4 period 3 cycles.

For 11-digit numbers in base 8 we have 1 fixed point: (0_{10}) , and 1 period 2 cycle, 1 period 4 cycle and 1 period 6 cycle.

For 12-digit numbers in base 8 we have 5 fixed points: (0_{10}) , (39258683100_{10}) , (57497839826_{10}) , (58573445322_{10}) and (68675650561_{10}) , and 1 period 2 cycle, 7 period 3 cycles and 1 period 4 cycle.

For 1-digit numbers in base 9 we have 1 fixed point: (0_{10}) .

For 2-digit numbers in base 9 we have 1 fixed point: (0_{10}) , and 1 period 2 cycle.

For 3-digit numbers in base 9 we have 1 fixed point: (0_{10}) , and 1 period 2 cycle.

For 4-digit numbers in base 9 we have 1 fixed point: (0_{10}) , and 2 period 3 cycles.

For 5-digit numbers in base 9 we have 2 fixed points: (0_{10}) , (41520_{10}) , and 1 period 5 cycle.

For 6-digit numbers in base 9 we have 1 fixed point: (0_{10}) , and 1 period 14 cycle.

For 7-digit numbers in base 9 we have 1 fixed point: (0_{10}) , and 1 period 2 cycle: $(3496800, 3916640)$.

For 8-digit numbers in base 9 we have 2 fixed points: (0_{10}) and (31531872_{10}) , and 1 period 4 cycle.

For 9-digit numbers in base 9 we have 2 fixed points: (0_{10}) and (326952560_{10}) , and 1 period 12 cycle.

For 10-digit numbers in base 9 we have 2 fixed points: (0_{10}) and (2598744000_{10}) , 1 period 4 cycle and 1 period 5 cycle.

For 11-digit numbers in base 9 we have 2 fixed points: (0_{10}) and (23087388720_{10}) , and 1 period 6 cycle.

For 12-digit numbers in base 9 we have 1 fixed point: (0_{10}) , and 2 period 2 cycles and 1 period 6 cycle.

10.5 Periodic cycles

For instance for 11-digit numbers in base 3 we found 3 fixed points and 1 period 2 cycle and 2 period 3 cycles. It will be denote briefly as $1_3, 2, 3_2$. The fixed points and period cycles for 1- through 12-digit numbers in base 2 through 10 are tabulated below.

base \ digits	2	3	4	5	6	7	8	9	10
1	1	1	1	1	1	1	1	1	1
2	1_2	1	$1, 2$	1_2	$1, 3$	1	$1_2, 3$	$1, 2$	$1, 5$
3	1_2	$1, 2$	1_2	$1, 2$	1_2	$1, 2$	1_2	$1, 2$	1_2
4	1_3	$1, 2$	$1_2, 2$	1_2	$1, 6$	$1, 3$	$1, 3, 5$	$1, 3_2$	1_2
5	1_3	1_2	$1, 2$	$1, 4$	$1_2, 2$	$1, 5$	$1, 2, 4$	$1_2, 5$	$1, 2, 4_2$
6	1_4	$1, 3$	1_4	$1, 5$	$1_4, 3$	$1, 6$	$1_3, 3$	$1, 14$	$1_3, 7$
7	1_4	$1_2, 2$	1_2	$1, 4$	$1, 2$	$1, 6$	$1_2, 4, 7$	$1, 2$	$1, 8$
8	1_5	1_2	$1_4, 3$	$1, 6$	$1_3, 2_2, 7$	$1, 6$	$1_2, 3_2$	$1_2, 4$	$1_3, 3, 7$
9	1_5	$1_2, 2, 3$	1_4	1_2	$1_2, 2$	$1, 11$	$1_2, 4, 5_2$	$1_2, 12$	$1_3, 14$
10	1_6	$1_2, 4$	$1_6, 2$	$1, 4$	$1_5, 2_3$	$1, 2_3$	$1_2, 3_4$	$1_2, 4, 5$	$1_4, 3_4, 7$
11	1_6	$1_3, 2, 3_2$	$1_4, 3$	$1_2, 3$	$1_3, 2$	1_2	$1, 2, 4, 6$	$1_2, 6$	$1_2, 5, 8$
12	1_7	$1_2, 2$	1_9	$1, 8$	$1_4, 2_6$	$1_2, 5$	$1_5, 2, 3_7, 4$	$1, 2_2, 6$	$1_8, 3_8, 7$

Chapter 11

Squared digit sum

11.1 Introduction

Well known is the iteration of an integer number to the sum of the squares of its digits. That is, if d_j are the digits of a positive integer number,

$$n_k = \sum_{j=0}^{\infty} d_j 10^j, \quad (11.1)$$

then

$$n_{k+1} = \sum_{j=0}^{\infty} d_j^2. \quad (11.2)$$

For $n_0 = 1$ the successor is $n_1 = 1^2 = 1$. That is, 1 is a fixed point. For $n_0 = 2$ the repeated iteration leads to the following orbit:

$$\begin{aligned} n_1 &= 2^2 = 4, & n_2 &= 4^2 = 16, & n_3 &= 1^2 + 6^2 = 37, \\ n_4 &= 3^2 + 7^2 = 58, & n_5 &= 5^2 + 8^2 = 89, & n_6 &= 8^2 + 9^2 = 145, \\ n_7 &= 1^2 + 4^2 + 5^2 = 42, & n_8 &= 4^2 + 2^2 = 20, & n_9 &= 2^2 + 0^2 = 4. \end{aligned}$$

That is, (4, 16, 37, 58, 89, 145, 42, 20) is a period 8 cycle.

It turns out there are no other cycles. This can be seen as follows. By numerical inspection it is quickly found that the orbit of n_0 arrives in either the fixed point 1 or the cycle (4, 16, 37, 58, 89, 145, 42, 20) if $0 < n_0 \leq 99$. If n_0 is a m -digit number then $10^{m-1} \leq n_0 < 10^m$. The largest m -digit number is $10^m - 1$. Its successor is $m \cdot 9^2 = 81m$. For a m -digit number $10^{m-1} \leq n_0 < 10^m$ the successor n_1 is smaller than $81m + 1$. Therefore n_1 is certainly smaller than n_0 if $81m + 1 < 10^{m-1}$. The latter inequality is satisfied if $m \geq 4$. So, numbers larger than or equal to 1000 have a smaller successor.

A 3-digit number is given by $n_0 = 100d_2 + 10d_1 + d_0$ and its successor is $n_1 = d_2^2 + d_1^2 + d_0^2$, where $1 \leq d_2 \leq 9$, $0 \leq d_1 \leq 9$ and $0 \leq d_0 \leq 9$.

If $3 \leq d_2 \leq 9$ and thus $300 \leq n_0 < 1000$ then $n_1 \leq 243 = 9^2 + 9^2 + 9^2$. So, $n_0 > n_1$ if $3 \leq d_2 \leq 9$.

If $d_2 = 2$ and thus $200 \leq n_0 < 300$ then $n_1 \leq 166 = 2^2 + 9^2 + 9^2$. So, $n_0 > n_1$ if $d_2 = 2$.

If $d_2 = 1$ then $n_0 = 100 + 10d_1 + d_0$ and $n_1 = 1 + d_1^2 + d_0^2$. Since $10d_1 > d_1^2$ and $100 + d_0 > 1 + d_0^2$ we have $n_0 > n_1$ if $d_2 = 1$.

We therefore can conclude that 3-digit numbers always have a smaller successor.

In summary, numbers with 3 or more digits will have a smaller successor. As a consequence, the orbit of numbers with 3 or more digits will always arrive below 100.

For numbers smaller than 100 we know from numerical inspection that the orbit will arrive at either 1 or $(4, 16, 37, 58, 89, 145, 42, 20)$. Hence, the orbit of all positive integers arrive at either 1 or $(4, 16, 37, 58, 89, 145, 42, 20)$. In the next diagram the n_1 are plotted against n_0 for $0 < n_0 \leq 250$.

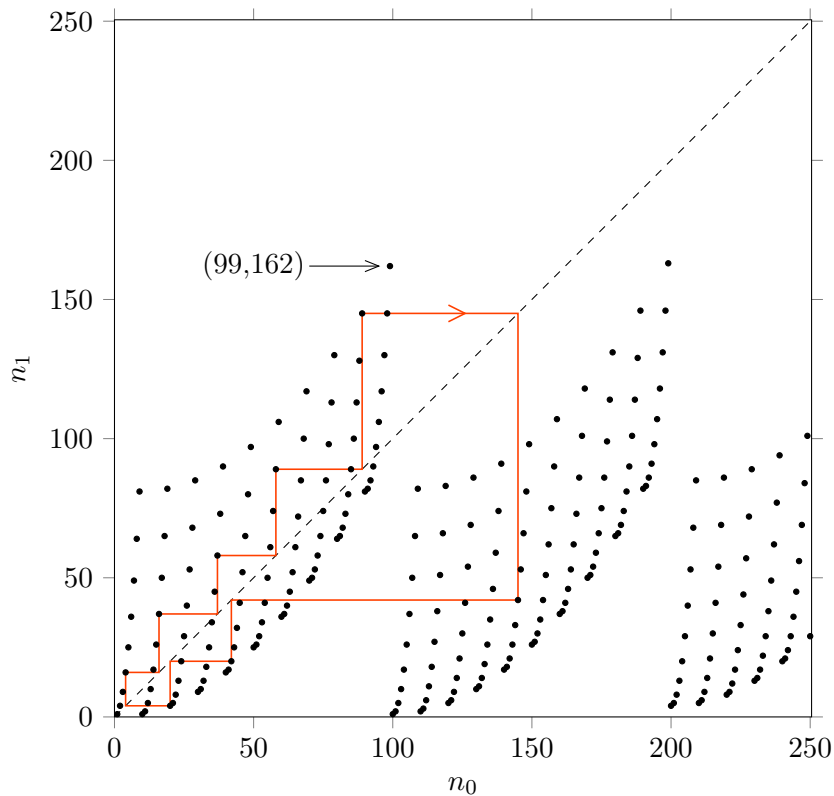

Figure 11.1: The black dots are the n_1 against n_0 for $0 < n_0 \leq 250$. The diagonal $n_1 = n_0$ is shown dashed. The period 8 cycle $(4, 16, 37, 58, 89, 145, 42, 20)$ is orange.

As shown in the diagram $n_0 = 99$ is the largest n_0 for which $n_1 = 162$ is larger than n_0 .

11.2 Statistics of cycle arrivals

We will denote the fixed point as c_1 and the period 8 cycle as c_2 . Thus $c_1 = (1)$ and $c_2 = (4, 16, 37, 58, 89, 145, 42, 20)$. For $n_0 \leq 10^k$ with $k = 1, 2, 3, 4, 5, 6$, the number of starting values for which the orbit ends in c_1 or c_2 are shown in the next table.

cycle	$n_0 \leq 10^1$	$n_0 \leq 10^2$	$n_0 \leq 10^3$	$n_0 \leq 10^4$	$n_0 \leq 10^5$	$n_0 \leq 10^6$
c_1	3	20	143	1442	14377	143071
c_2	7	80	857	8558	85623	856929

The figures in the table suggest the fraction of $n_0 \leq n$ for which the orbit ends in the fixed point 1 converges smoothly to approximately 0.143. This is, however, not the case. The curve of the fraction of $n_0 \leq n$ for which the orbit ends in the fixed point 1 is bumpy, see next figure.

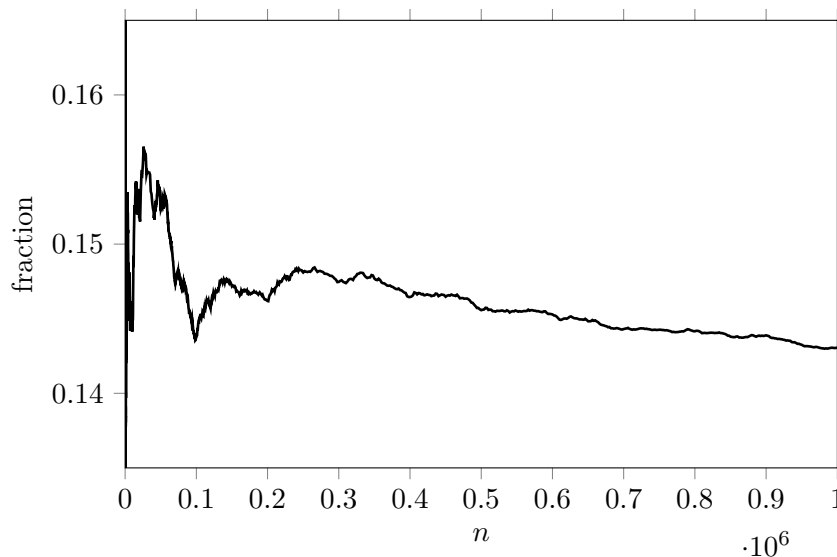

Figure 11.2: The fraction of $n_0 \leq n$ for which the orbits arrives at 1.

11.3 Statistics of untouchables

If we start with $n_0 = 2$, then the orbit is 2, 4, 16, 37, 58, 89, 145, 42, 20, 4, ... So, if we start with numbers smaller than 3, the number 2 is untouchable. Since 2 is $1^2 + 1^2$ we have to wait until starting number $n_0 = 11$ before 2 becomes touchable. As before, we keep track of the smallest starting number t_n for which a number n is no longer untouchable.

If we start with numbers smaller than 10^3 , the first part of the list of t_n is:

n	1	2	3	4	5	6	7	8	9	10	11	12	13	14.	15	16	17	18	19	20	21	22	23	24	25	26
t_n	1	11	111	2	12	112	?	22	3	7	78	222	23	123	?	2	6	33	133	2	124	233	?	224	5	15

The question marks show that for starting numbers smaller than 10^3 the numbers 7, 15, 23, ... are untouchable. Since

$$\sum_{k=1}^n 1^2 = n \tag{11.3}$$

any number consisting of solely n digits 1 will make n touchable. The question mark will therefore sooner or later disappear. For instance, if $n_0 = 1111111$ gives $n_1 = 7$. Of course, $n_0 = 1112$ also gives $n_1 = 7$.

For starting numbers smaller than 10^4 the first part of the list of t_n is as follows:

1, 11, 111, 2, 12, 112, 1112, 22, 3, 7, 78, 222, 23, 123, 1123, 2, 6, 33, 133, 2, 124, 233, 1233, 224, 5, 15, 115, 1115, 5, 125, 1125, 44, 144, 27, 135, 6, 2, 116, 1116, 15, 6, 2, 335, 226, 6, 136, 1136, 444, 7, 6, 69, 8, 27, 127, 1127, 246, 227, 2, 137, 1137, 3, 156, 1156, 8, 3, 118, 337, 19, 88, 356, 1356, 66, 38, 57, 157, 266, 238, 257, 1257, 48, 3, 19, 119, 248, 5, 129, 1129, 466, 2, 39, 139, 1139, 258, 239, 1239, 448, 7, 77, 177, 19, 168, 277, 1277, 268, 458, 59, 159, 666, 368, 259, 1259, 2666, 78, 178, 359, 468, 69, 169, 1169, 2468, 269, 378, 577, 1577, 568, 369, 1369, 88, 188, 7, 179, 288, 469, 279, 1279, 668, 388, 578, 379, 1379, 2388, 569, 1569, 488, 2, 189, 777, 1777, 289, 1289, 2777, 4668, 588, 389, 579, 1579, 2588, 2389, 2579, 4488, 489, 99, 199, 688, 1688, 299, 1299, 2688, 4588, 589, 399, 1399, 3688, 2589, 2399, ?, 788,...

Now the first question mark is for $n = 176$.

For starting numbers smaller than 10^5 the first question mark is for $n = 286$.

For starting numbers smaller than 10^6 the first question mark is for $n = 367$.

If we only start with numbers from the set $\{1,2\}$, then 2 is the only element of the set $\{1,2\}$ which is untouchable. The ratio of the number of untouchables and set length is $1/2$. If we only start with numbers from the set $\{1,2,3,4,5,6,7,8,9,10\}$, then 2, 3, 5, 6, 7 and 8 are the untouchable elements. The ratio of the number of untouchables and set length is $6/10$. As before, we let u_n be the number of elements which are untouchable if we only start with numbers from the set $\{1,2,3,\dots,n\}$. For n up to 10^6 the ratio u_n/n is plotted against n in the next figure.

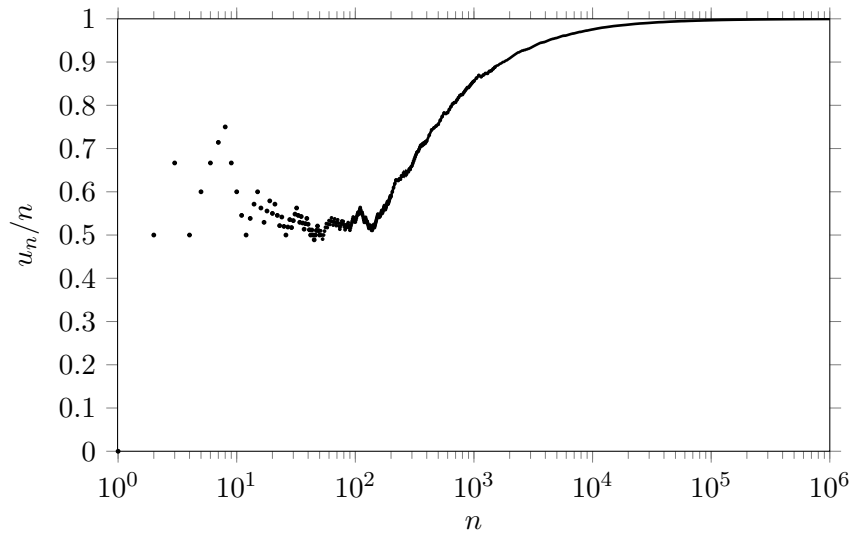

Figure 11.3: The ratio u_n/n for the digits factorial sum.

The latter diagram suggest $\lim_{n \rightarrow \infty} \frac{u_n}{n} = 1$ for the squared digit sum iteration.

11.4 Statistics of distances

Since $n_{k+1} < n_k$ for $n_k \geq 100$ orbits will fast descend to below 100 and arrive at the fixed point c_1 or the period 8 cycle c_2 . Therefore the distances are limited. The distribution of distances for the squared digit sum iteration in base 10 is shown in the next figure.

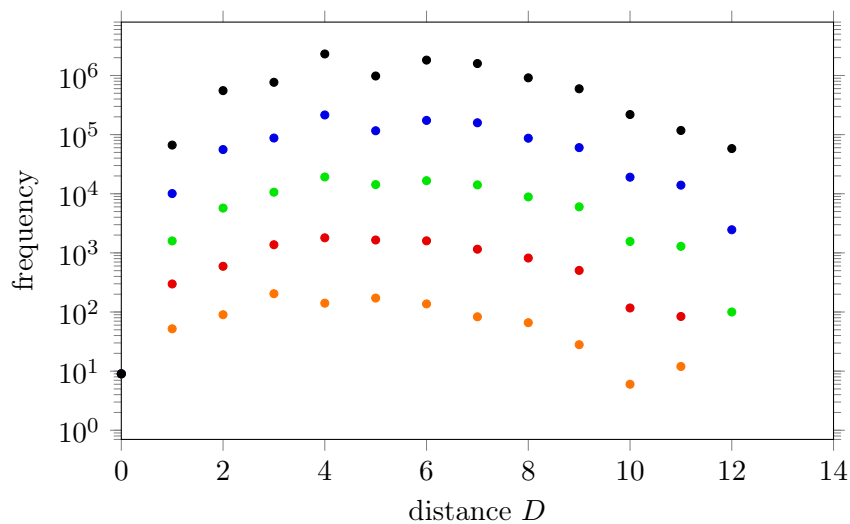

Figure 11.4: Base 10 distribution of distances for starting numbers smaller than or equal to: 10^3 (orange), 10^4 (red), 10^5 (green), 10^6 (blue), 10^7 (black).

11.5 Other bases

The squared digit sum iteration can be generalized to an arbitrary base b . That is, if d_j are the digits of an integer number in base b ,

$$n_k = \sum_{j=0}^{\infty} d_j b^j, \quad (11.4)$$

then

$$n_{k+1} = \sum_{j=0}^{\infty} d_j^2. \quad (11.5)$$

If n_0 is a m -digit number in base b then $b^{m-1} \leq n_0 < b^m$. The largest m -digit number is $b^m - 1$. Its successor is $m \cdot (b-1)^2$. For a m -digit number $b^{m-1} \leq n_0 < b^m$ the successor n_1 is smaller than $m(b-1)^2 + 1$. Therefore n_1 is certainly smaller than n_0 if $m(b-1)^2 + 1 < b^{m-1}$. The latter inequality is satisfied if $m \geq 4$. So, numbers with 4 or more digits have a smaller successor.

Again, for 3-digit numbers we let d_2, d_1 and d_0 be the digits. Then a 3-digit number in base b is given by $n_0 = b^2 d_2 + b d_1 + d_0$ and its successor is $n_1 = d_2^2 + d_1^2 + d_0^2$, where $1 \leq d_2 \leq b-1$, $0 \leq d_1 \leq b-1$ and $0 \leq d_0 \leq b-1$.

If $d_2 = 1$ then $n_0 = b^2 + b d_1 + d_0$ and $n_1 = 1 + d_1^2 + d_0^2$. Since $b^2 + d_0 > 1 + d_0^2$ and $b d_1 > d_1^2$ we have $n_0 > n_1$ if $d_2 = 1$.

If $d_2 = 2$ and thus $b \geq 3$ and $n_0 = 2b^2 + b d_1 + d_0 \geq 2b^2$, then $n_1 = 4 + d_1^2 + d_0^2 \leq 4 + (b-1)^2 + (b-1)^2 < 2b^2$. So, $n_0 > n_1$ if $d_2 = 2$.

If $3 \leq d_2 \leq b-1$ then $n_0 = b^2 d_2 + b d_1 + d_0 \geq 3b^2$ while $n_1 = d_2^2 + d_1^2 + d_0^2 \leq 3(b-1)^2 < 3b^2$. So, $n_0 > n_1$ if $d_2 \geq 3$.

We therefore can conclude that for 3-digit numbers in base b there always holds $n_1 < n_0$.

In summary, in any base b numbers with 3 or more digits will have a smaller successor. As a consequence, in any base b the orbit of numbers with 3 or more digits will always arrive below b^2 .

For numbers smaller than b^2 the cycles are determined by numerical inspection.

For base 9 we found in this way three fixed points: $1_9 = 1_{10}$, $45_9 = 41_{10}$ and $55_9 = 50_{10}$, one period 2 cycle: $(75_9, 82_9) = (68_{10}, 74_{10})$, and one period 3 cycle: $(58_9, 108_9, 72_9) = (53_{10}, 89_{10}, 65_{10})$. In the next diagram the n_1 are plotted against n_0 for $0 \leq n_0 \leq 200$.

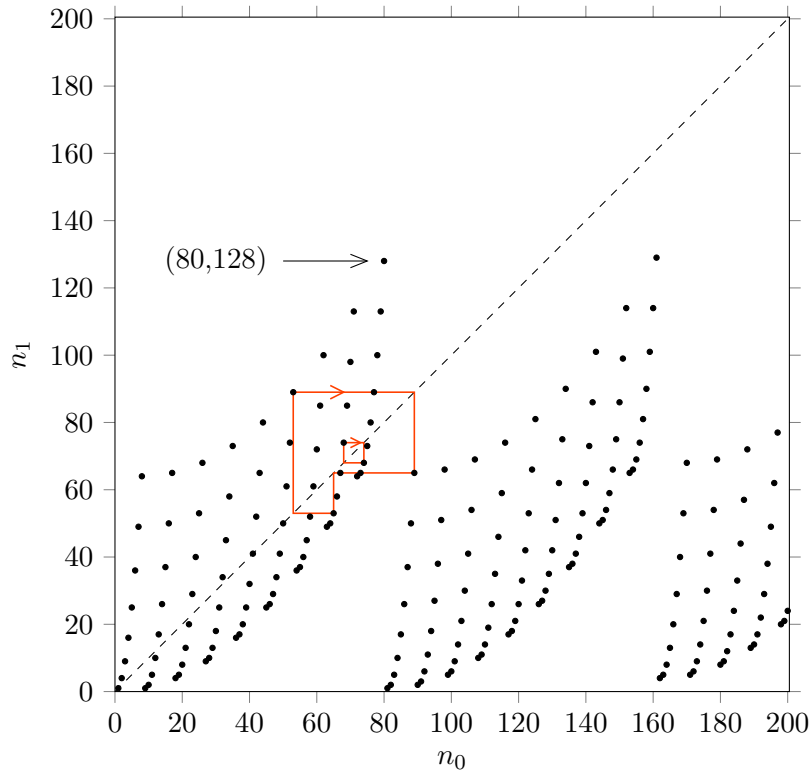

Figure 11.5: The n_1 against n_0 for $0 < n_0 < 200$ for the case where the iteration is performed in base 9. The diagonal $n_1 = n_0$ is dashed. The period 2 and period 3 cycle are orange.

The distribution of distances is shown in the next figure.

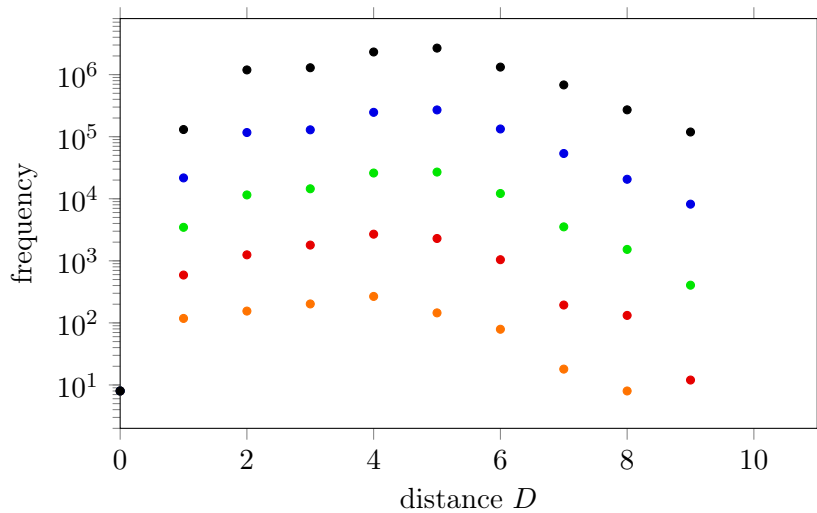

Figure 11.6: Base 9 distribution of distances for starting numbers smaller than or equal to: 10^3 (orange), 10^4 (red), 10^5 (green), 10^6 (blue), 10^7 (black).

In base 8 there are three fixed points: $1_8 = 1_{10}$, $24_8 = 20_{10}$ and $64_8 = 52_{10}$, two period 2 cycles: $(4_8, 20_8) = (4_{10}, 16_{10})$ and $(32_8, 15_8) = (26_{10}, 13_{10})$, and one period 3 cycle: $(5_8, 31_8, 12_8) = (5_{10}, 25_{10}, 10_{10})$. The distribution of distances is

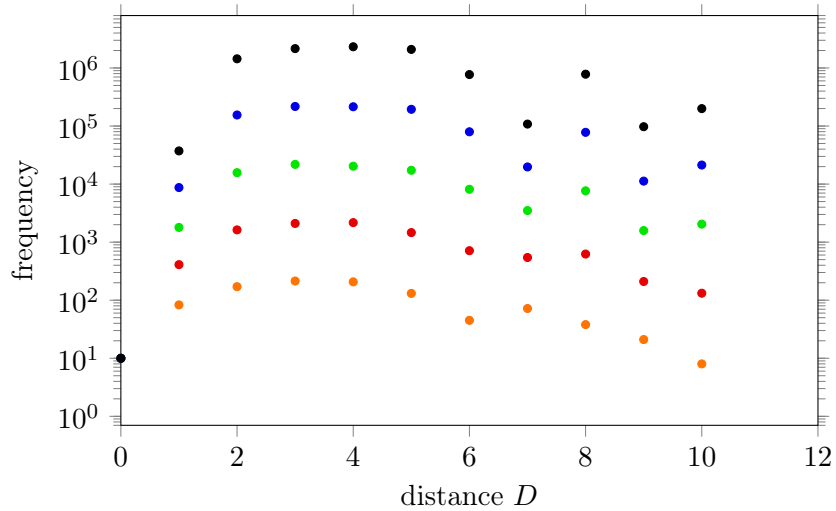

Figure 11.7: Base 8 distribution of distances for starting numbers smaller than or equal to: 10^3 (orange), 10^4 (red), 10^5 (green), 10^6 (blue), 10^7 (black).

In base 7 there exist five fixed points: $1_7 = 1_{10}$, $13_7 = 10_{10}$, $34_7 = 25_{10}$, $44_7 = 32_{10}$ and $63_7 = 45_{10}$, and two period 4 cycles: $(2_7, 4_7, 22_7, 11_7) = (2_{10}, 4_{10}, 16_{10}, 8_{10})$ and $(23_7, 16_7, 52_7, 41_7) = (17_{10}, 13_{10}, 37_{10}, 29_{10})$. The distribution of distances is

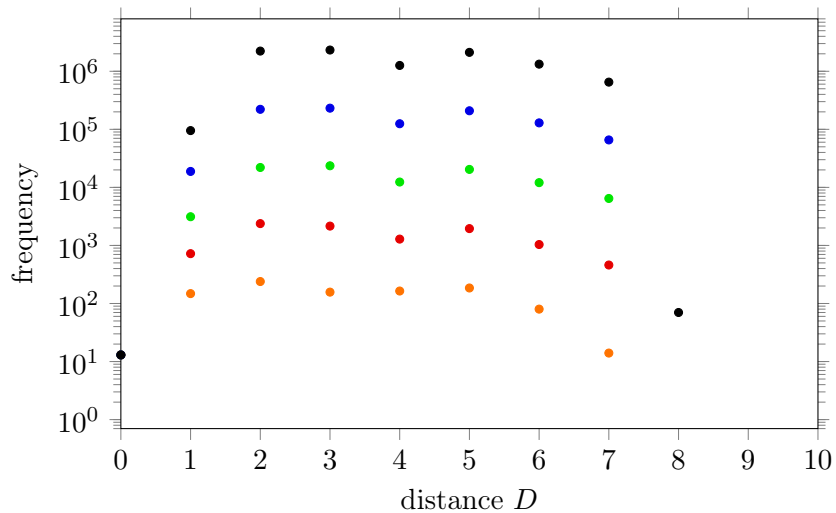

Figure 11.8: Base 7 distribution of distances for starting numbers smaller than or equal to: 10^3 (orange), 10^4 (red), 10^5 (green), 10^6 (blue), 10^7 (black).

In base 6 there exist one fixed point: $1_6 = 1_{10}$, and one period 8 cycle:
 $(32_6, 21_6, 5_6, 41_6, 25_6, 45_6, 105_6, 42_6) = (20_{10}, 13_{10}, 5_{10}, 25_{10}, 17_{10}, 29_{10}, 41_{10}, 26_{10})$.
 The distribution of distances is

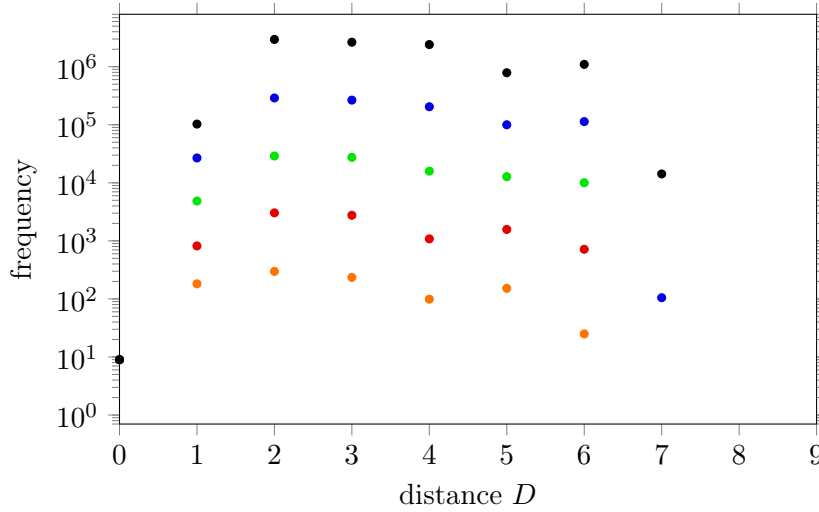

Figure 11.9: Base 6 distribution of distances for starting numbers smaller than or equal to: 10^3 (orange), 10^4 (red), 10^5 (green), 10^6 (blue), 10^7 (black).

In base 5 there exist three fixed points: $1_5 = 1_{10}$, $23_5 = 13_{10}$ and $33_5 = 18_{10}$, and one period 3 cycle: $(4_5, 31_5, 20_5) = (4_{10}, 16_{10}, 10_{10})$. The distribution of distances is

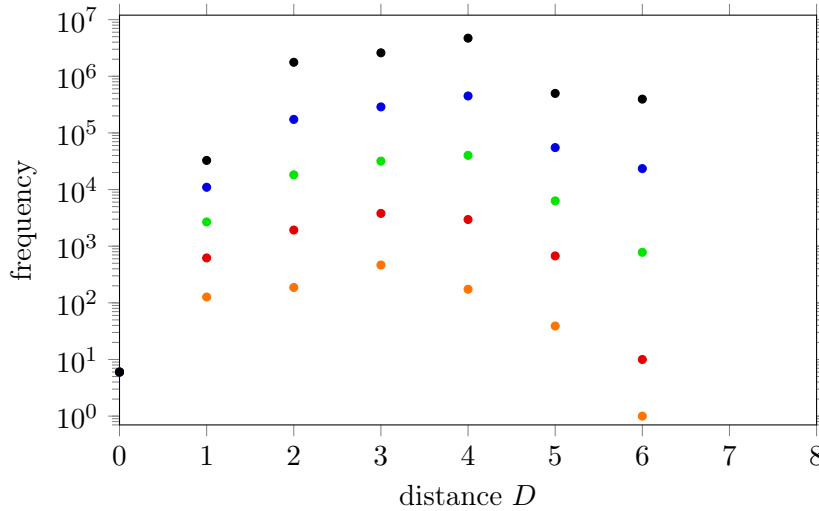

Figure 11.10: Base 5 distribution of distances for starting numbers smaller than or equal to: 10^3 (orange), 10^4 (red), 10^5 (green), 10^6 (blue), 10^7 (black).

In base 4 there exists only one fixed point: $1_4 = 1_{10}$. The distribution of distances is

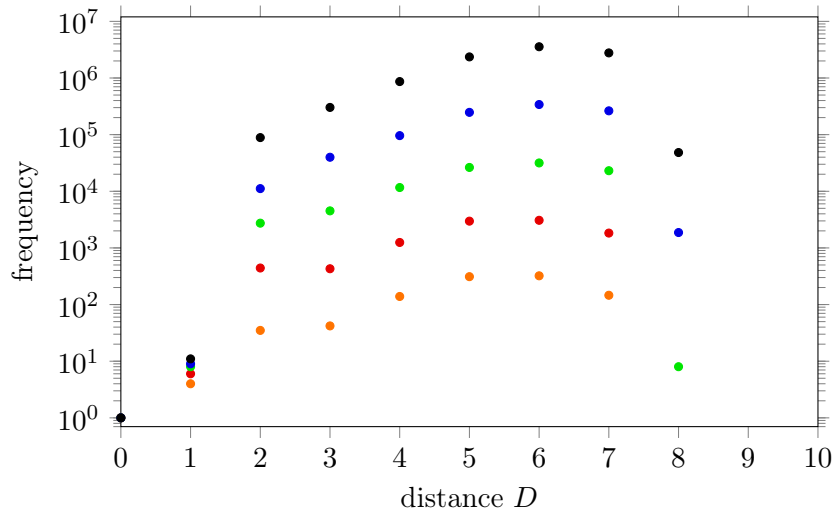

Figure 11.11: Base 4 distribution of distances for starting numbers smaller than or equal to: 10^3 (orange), 10^4 (red), 10^5 (green), 10^6 (blue), 10^7 (black).

In base 3 there exist 3 fixed points: $1_3 = 1_{10}$, $12_3 = 5_{10}$ and $22_3 = 8_{10}$, and one period 2 cycle: $(2_3, 11_3) = (2_{10}, 4_{10})$. The distribution of distances is

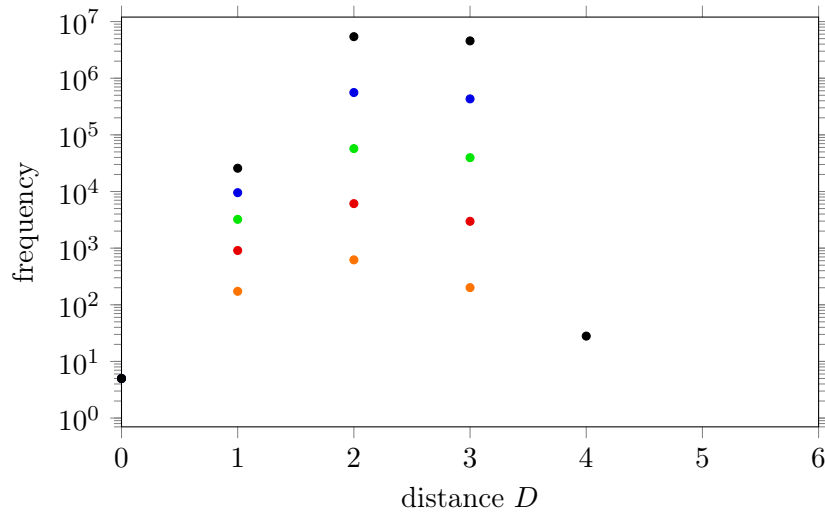

Figure 11.12: Base 3 distribution of distances for starting numbers smaller than or equal to: 10^3 (orange), 10^4 (red), 10^5 (green), 10^6 (blue), 10^7 (black).

In base 2 there exists only one fixed point: $1_2 = 1_{10}$. The distribution of distances is

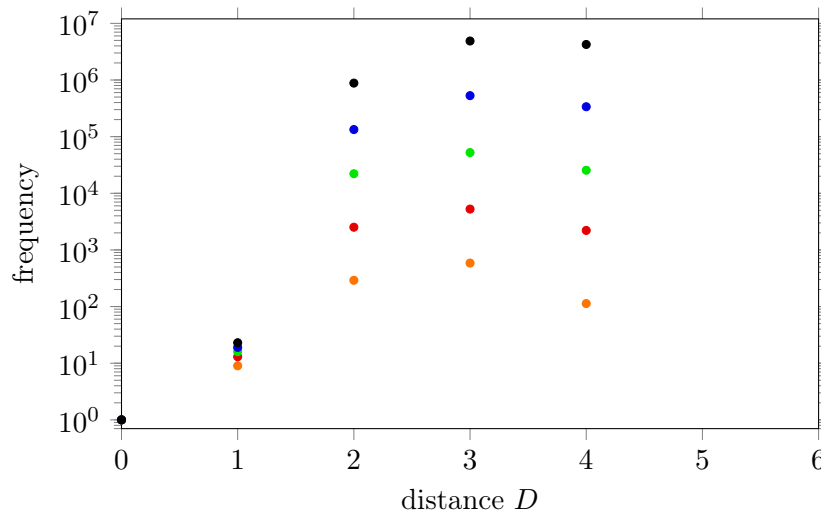

Figure 11.13: Base 2 distribution of distances for starting numbers smaller than or equal to: 10^3 (orange), 10^4 (red), 10^5 (green), 10^6 (blue), 10^7 (black).

For the square digit sum iteration in base 8 we found 3 fixed points and 2 period 2 cycles and 1 period 3 cycle. The cycle periods p will be denote briefly as $1_3, 2_2, 3$. The p for the square digit sum iteration in base 2 through 10 are tabulated below.

base	2	3	4	5	6	7	8	9	10
p	1	$1_3, 2$	1	$1_3, 3$	$1, 8$	$1_5, 4_2$	$1_3, 2_2, 3$	$1_3, 2, 3$	$1, 8$

11.6 Happy numbers

For the squared digit sum iteration in base b a positive integer whose orbit arrives at 1 is called a happy number. In base 10, for example, 7 is a happy number since its orbit goes as 7, 49, 97, 130, 10, 1. In base 10 the first view happy numbers are 1, 7, 10, 13, 19, 23, 28, 31, 32, 44, 49, 68, 70, 79, 82, 86, 91, 94, 97, 100, ... The latter sequence is known as the A007770 sequence of the OEIS [2]. In base 6, as another example, $112_6 = 44_{10}$ is a happy number since its orbit goes as $112_6, 10_6, 1_6$. Presented in base 10 the latter orbit is 44, 6, 1. Presented in base 10 the first view happy numbers in base 6 are 1, 6, 36, 44, 49, 79, 100, 160, 170, 216, 224, 229, 254, 264, 275, 285, 289, 294, 335, 347, 355, 357, 388, ...

In base 2 and base 4 there exists no other periodic cycles than the single fixed point $1_2 = 1_{10}$

and $1_4 = 1_{10}$ respectively. As a consequence, in base 2 all orbits will arrive at 1 and in base 4 all orbits will arrive at 1. That is, in base 2 all numbers are happy and in base 4 all numbers are happy. For this reason base 2 and base 4 are called *happy bases*. The only happy bases less than $5 \cdot 10^8$ are base 2 and base 4. It is still an unsolved problem whether base 2 and base 4 are the only happy bases.

In any base b the fraction of starting values for which the orbit ends in 1 is called the *density* of happy numbers.

For $n_0 \leq 10^6$ the density of happy numbers in base 10 is approximately 0.143.

For $n_0 \leq 10^6$ the density of happy numbers in base 9 is approximately 0.0733.

For $n_0 \leq 10^6$ the density of happy numbers in base 8 is approximately 0.0571.

For $n_0 \leq 10^6$ the density of happy numbers in base 7 is approximately 0.0154.

For $n_0 \leq 10^6$ the density of happy numbers in base 6 is approximately 0.0557.

For $n_0 \leq 10^6$ the density of happy numbers in base 5 is approximately 0.206.

For $n_0 \leq 10^6$ the density of happy numbers in base 4 is exactly 1.

For $n_0 \leq 10^6$ the density of happy numbers in base 3 is approximately 0.267.

For $n_0 \leq 10^6$ the density of happy numbers in base 2 is exactly 1.

In each of the above bases the curve of the density against n is rather wobbly. We saw that already for the density curve in base 10. To illustrate it once more we show the density curve in base 6 for $10^5 \leq n \leq 10^6$.

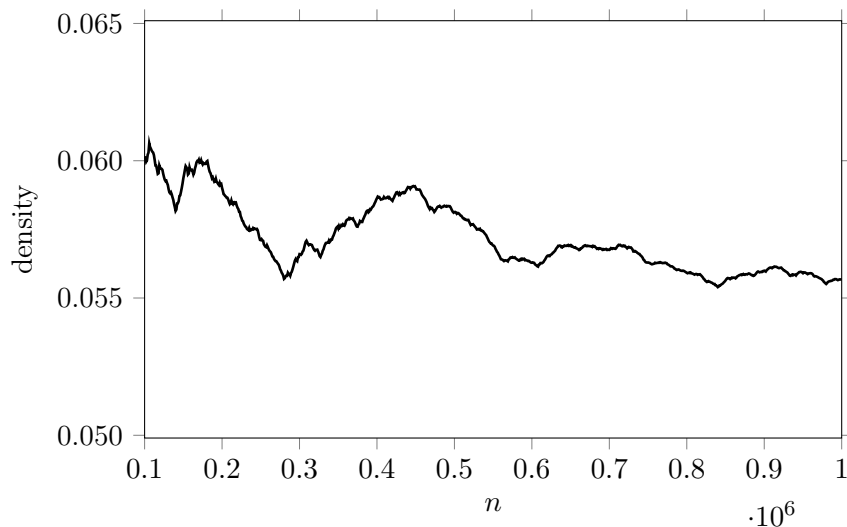

Figure 11.14: The density of happy numbers $n_0 \leq n$ in base 6 for $10^5 \leq n \leq 10^6$.

Because of the descending trend of the density curve it is not clear if the density converges to a limit value in the limit $n \rightarrow \infty$.

Chapter 12

Digits factorial sum

12.1 Introduction

Another way to play with the digits of a numbers is by taking the sum of the factorials of the digits [5]. For instance, if we start with the number 147, then the sum of the factorials of the digits is $1! + 4! + 7! = 1 + 24 + 5040 = 5065$. Repeating the process gives $5! + 0! + 6! + 5! = 120 + 1 + 720 + 120 = 961$, $9! + 6! + 1! = 362880 + 720 + 1 = 363601$, $3! + 6! + 3! + 6! + 0! + 1! = 6 + 720 + 6 + 720 + 1 + 1 = 1454$, $1! + 4! + 5! + 4! = 1 + 24 + 120 + 24 = 169$, $1! + 6! + 9! = 1 + 720 + 362880 = 363601$. That is, the sequence ends at the period 3 cycle (169, 363601, 1454). Formally, let $\{d_m, d_{m-1}, \dots, d_2, d_1, d_0\}$, with $d_m > 0$, be the $m + 1$ digits of n . Thus $n = \sum_{j=0}^m d_j 10^j$. Then the digits factorial sum \mathcal{F} is defined as

$$\mathcal{F}(n) = \sum_{j=0}^m d_j! . \quad (12.1)$$

The largest number n with $m + 1$ digits is $\sum_{j=0}^m 9 \cdot 10^j$. After one iteration we obtain $\mathcal{F}(n) = (m + 1) \cdot 9! = 362880(m + 1)$. The largest number with 7 digits is 9999999. After one iteration we obtain $\mathcal{F}(9999999) = 7 \cdot 9! = 2540160$. Since 2540160 is smaller than 9999999, we know for sure that a sequence of numbers generated by the digits factorial process eventually will be smaller than or equal to 2540160: $\mathcal{F}(n) \leq 2540160$ for $n \leq 9999999$. For $n \leq 2540160$ the largest number $\mathcal{F}(n)$ is 2177281. It only occurs for $n = 1999999$: $\mathcal{F}(1999999) = 2177281$. Since $\mathcal{F}(2177281) = 50406$, which is much smaller than 2177281, it is of interest to see for the largest number after two iterations starting with numbers smaller than or equal to 2540160. Or even better, to see for the largest number after i iterations starting with numbers smaller than or equal to 2540160. The results are shown in the next table.

i	maximum number	i	maximum number	i	maximum number
0	2540160	13	726493	26	404670
1	2177281	14	726493	27	404670
2	1094406	15	726493	28	404670
3	766106	16	443520	29	404670
4	766106	17	443520	30	404670
5	730800	18	443520	31	404670
6	726608	19	443520	32	404670
7	726608	20	443520	33	404670
8	726608	21	443520	34	404670
9	726608	22	443520	35	404670
10	726493	23	443520	36	404670
11	726493	24	443520	37	363601
12	726493	25	443520	38	363601

The maximum number will never descend below 363601 since 363601 is an element of the cycle (169, 363601, 1454).

12.2 Cycles of the \mathcal{F} function

A numerical inspection of numbers smaller than 363601 delivers the following periodic cycles:

four fixed points: (1), (2), (145), (40585),
two period 2 cycles: (871, 45361), (872, 45362) and
one period 3 cycle (169, 363601, 1454).

We will denote the periodic cycles as follows:

$c_1 = (1)$, $c_2 = (2)$, $c_3 = (145)$, $c_4 = (40585)$,
 $c_5 = (871, 45361)$, $c_6 = (872, 45362)$ and
 $c_7 = (169, 363601, 1454)$.

The cycles c_5 and c_6 are known as A214285 of the OEIS and the cycle c_7 is known as A308259 of the OEIS [2].

12.3 Statistics of cycle arrivals

For $n_0 \leq 10^k$ with $k = 1, 2, 3, 4, 5, 6, 7$, the number of starting values for which the orbit ends in $c_1, c_2, c_3, c_4, c_5, c_6$ or c_7 are shown in the next table.

cycle	$n \leq 10^1$	$n \leq 10^2$	$n \leq 10^3$	$n \leq 10^4$	$n \leq 10^5$	$n \leq 10^6$	$n \leq 10^7$
c_1	1	1	1	1	1	1	1
c_2	2	3	12	138	2679	25789	251822
c_3	0	0	10	10	318	7454	63931
c_4	0	0	0	0	108	504	14627
c_5	0	2	12	76	666	6261	83873
c_6	0	0	12	96	558	6679	40089
c_7	7	94	953	9679	95670	953312	9545657

We see approximately 95.5% of the orbits ends at the (169, 363601, 1454) cycle and approximately 2.5% ends at the fixed point (2).

12.4 Statistics of untouchables

If we start with $n_0 = 3$, then the orbit is 3, 6, 720, 5043, 151, 122, 5, 120, 4, 24, 26, 722, 5044, 169, 363601, 1454, 169, So, if we start with numbers smaller than 4, the numbers 1, 2, 4, 5 and 6 are touchable, while the numbers 3, 7, 8, 9, etc. are untouchable. If we start with $n_0 = 8$, then the orbit is 8, 40320, 34, 30, 7, and so on until it arrives at the period 3 cycle c_7 . That is, if we start with numbers smaller than 9, the number 7 is no longer untouchable. Also here we keep track of the smallest starting number t_n for which a number n is no longer untouchable.

If we start with numbers smaller than 10^3 , the first part of the list of t_n is:

n	1	2	3	4	5	6	7	8	9	10	11	12	13	14.	15	16	17	18	19	20	21	22	23	24	25	26	27	28
t_n	1	2	12	3	3	3	8	23	45	223	569	33	133	233	?	?	?	333	?	?	?	?	?	3	14	3	55	37

We see $t_7 = 8$ as mentioned before. The question marks show that for starting numbers smaller than 1000 the numbers 15, 16, 17, 19, 20, 21, 22, 23, ... are untouchable. Question marks may disappear by taking larger starting numbers.

For starting numbers smaller than 10^7 the first part of the list of t_n is as follows:

1, 2, 12, 3, 3, 3, 8, 23, 45, 223, 569, 33, 133, 233, 1233, 2233, 12233, 333, 1333, 2333, 12333, 22333, 122333, 3, 14, 3, 55, 37, 1224, 8, 134, 234, 1234, 8, 28, 246, 1334, 2238, 128, 499, 2589, 3334, 1338, 23334, 12589, 223334, 1223334, 44, 45, 66, 68, 268, 12244, 344, 1266, 377, 7, 1299, 489, 3344, 2338, 23344, 1229, 223344, 1223344, 33344, 133344, 233344, 1233344, 2233344, ?, 444, 1444, 58, 9, 22444, 122444, 3444, 36, 5589, 25589, 223444, 1223444, 33444, 4589, 233444, 1233444, 2233444, ?, 333444, 1333444, 2333444, ?, ?, ?, 4444, 9,...

Now the first question mark is for $n = 71$.

It raises the question whether or not all numbers eventually become touchable if large enough starting numbers are used or do there exist truly untouchable numbers in the sense that they stay untouchable even if infinitely large starting numbers are used.

If we only start with numbers from the set $\{1, 2, 3\}$, then 3 is the only element of the set $\{1, 2, 3\}$ which is untouchable. The ratio of the number of untouchables and set length is $1/3$. If we only start with numbers from the set $\{1, 2, 3, 4, 5, 6, 7, 8, 9, 10\}$, then 3, 8, 9 and 10 are the only untouchable elements. The ratio of the number of untouchables and set length is $4/10$. As before, we let u_n be the number of elements which are untouchable if we only start with numbers from the set $\{1, 2, 3, \dots, n\}$. For numbers up to 10^7 the ratio u_n/n is plotted against n in the next figure.

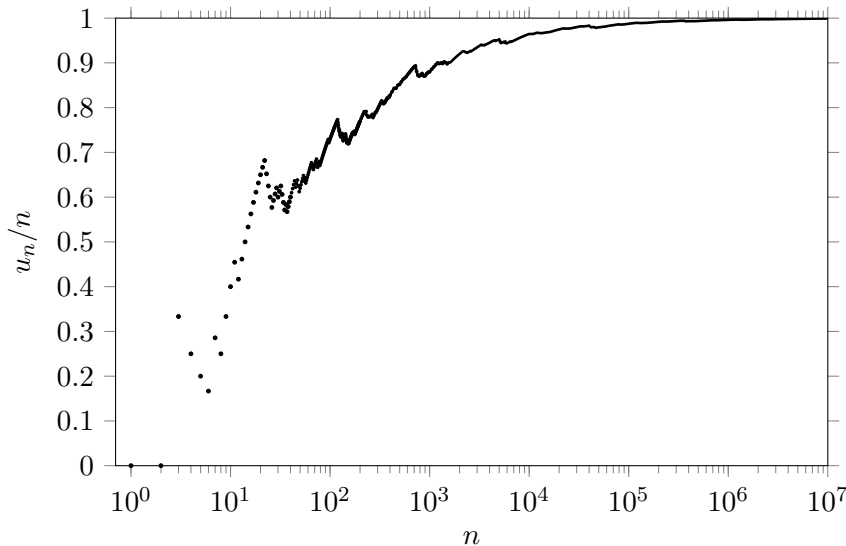

Figure 12.1: The ratio u_n/n for the digits factorial sum.

The latter diagram suggest $\lim_{n \rightarrow \infty} \frac{u_n}{n} = 1$ for the digits factorial sum.

12.5 Statistics of distances

For instance, the orbit 4, 24, 26, 722, 5044, 169 implies $D(4) = 5$. There are more starting values for which the distance is 5. The distribution of distances is shown in the next figure.

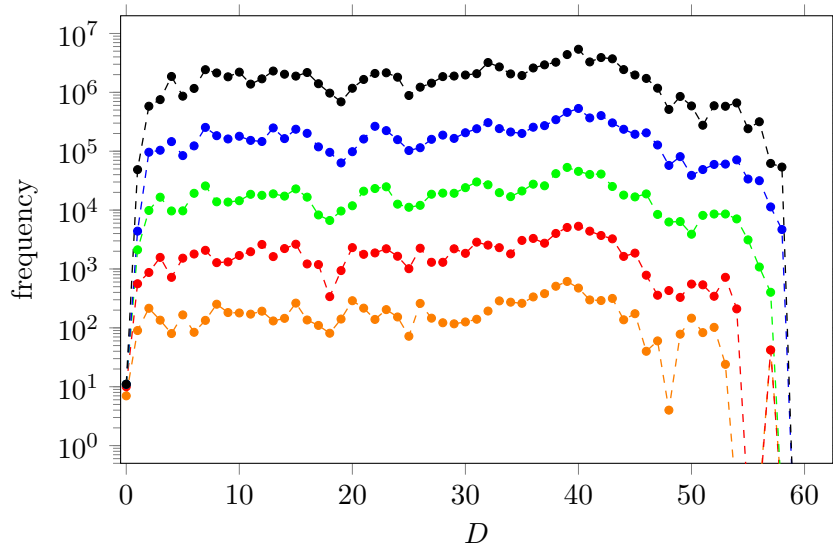

Figure 12.2: Distribution of distances for starting numbers smaller than or equal to: 10^4 (orange), 10^5 (red), 10^6 (green), 10^7 (blue), 10^8 (black).

12.6 Records of distances

Since 1 and 2 are fixed points, we have $D(1) = D(2) = 0$. From the orbit 3, 6, 720, 5043, 151, 122, 5, 120, 4, 24, 26, 722, 5044, 169, 363601, 1454, 169 ... we see that for starting value 3 it takes 13 steps to arrive at a cycle. Thus $D(3) = 13$, which is a distance record. The distance records are tabulated for $n_0 \leq 10^9$.

#	1	2	3	4	5	6	7	8	9	10
n_0	3	7	8	23	36	45	229	1479	1 233 466	246 779 999
D record	13	29	33	34	45	51	52	57	58	59

It raises the following question: for which $n_0 > 10^9$ will show up a distance record larger than 59?

12.7 Records of maximums

As we saw before, starting number 3 has orbit 3, 6, 720, 5043, 151, 122, 5, 120, 4, 24, 26, 722, 5044, 169, 363601, 1454, 169, ... The maximum value of the orbit is 363601, thus $M(3) = 363601$. As follows from the orbit of 3, $M(4) = M(5) = M(6) = 363601$. Starting number 7 has orbit 7, 5040, 146, 745, 5184, 40465, 889, 443520, 177, 10081, 40324, 57, 5160, 842, 40346, 775, 10200, 6, 720, 5043, 151, 122, 5, 120, 4, 24, 26, 722, 5044, 169, ... That is, $M(7) = 443520$, which is a new maximum record. Continuing the search we find the next maximum record for $n = 45$: $M(45) = 726493$. The maximum records are tabulated below for $n \leq 2177286$.

#	n	M record	#	n	M record	#	n	M record
1	3	363 601	13	7999	1 093 680	25	199 999	1 814 401
2	7	443 520	14	8999	1 128 960	26	299 999	1 814 402
3	45	726 493	15	9999	1 451 520	27	399 999	1 814 406
4	799	730 800	16	19 999	1 451 521	28	499 999	1 814 424
5	899	766 080	17	29 999	1 451 522	29	599 999	1 814 520
6	999	1 088 640	18	39 999	1 451 526	30	699 999	1 815 120
7	1999	1 088 641	19	49 999	1 451 544	31	799 999	1 819 440
8	2999	1 088 642	20	59 999	1 451 640	32	899 999	1 854 720
9	3999	1 088 646	21	69 999	1 452 240	33	999 999	2 177 280
10	4999	1 088 664	22	79 999	1 456 560	34	1 999 999	2 177 281
11	5999	1 088 760	23	89 999	1 491 840	35	2 177 282	2 177 282
12	6999	1 089 360	24	99 999	1 814 400	36	2 177 283	2 177 283

For $n \geq 2177282$ the maximum record equals the starting value of the orbit. So, for the digits factorial sum it is not interesting to look for maximum records other than the ones shown in the table above.

Chapter 13

\mathcal{P} function

13.1 Pillai's function

For a number n Pillai's arithmetical function $P(n)$ is defined as follows

$$P(n) = \sum_{j=1}^n \gcd(j, n) , \quad (13.1)$$

where $\gcd(j, n)$ is the greatest common divisor of j and n . An equivalent expression for Pillai's arithmetical function is

$$P(n) = \sum_{d|n} d \varphi(n/d) . \quad (13.2)$$

The summation is over all divisors d of n . Euler's totient function $\varphi(n)$ counts the positive integers up to a number n that are relatively prime to n . Another equivalent expression is

$$P(n) = \sum_{d|n} d \tau(d) \mu(n/d) , \quad (13.3)$$

where τ is the divisor function and μ is the Möbius function. The divisor function $\tau(n)$ counts the number of divisors of n . The Möbius function is defined as follows:

$$\mu(n) = \begin{cases} +1 & \text{if } n \text{ is a square-free positive integer with an even number of prime factors,} \\ -1 & \text{if } n \text{ is a square-free positive integer with an odd number of prime factors,} \\ 0 & \text{if } n \text{ has a squared prime factor.} \end{cases} \quad (13.4)$$

For $n = 6$, for instance, we will obtain $P(6) = 15$ with any of the above three functions:

$$P(6) = \gcd(1, 6) + \gcd(2, 6) + \dots + \gcd(6, 6) = 1 + 2 + 3 + 2 + 1 + 6 = 15.$$

$$P(6) = 1 \cdot \varphi(6) + 2\varphi(3) + 3\varphi(2) + 6\varphi(1) = 1 \cdot 2 + 2 \cdot 2 + 3 \cdot 1 + 6 \cdot 1 = 2 + 4 + 3 + 6 = 15.$$

$$P(6) = 1 \cdot \tau(1)\mu(6) + 2\tau(2)\mu(3) + 3\tau(3)\mu(2) + 6\tau(6)\mu(1) = 1 \cdot 1 \cdot 1 - 2 \cdot 2 \cdot 1 - 3 \cdot 2 \cdot 1 + 6 \cdot 4 \cdot 1 \\ = 1 - 4 - 6 + 24 = 15.$$

The set $\{\gcd(1, 6), \gcd(2, 6), \gcd(3, 6), \gcd(4, 6), \gcd(5, 6), \gcd(6, 6)\} = \{1, 2, 3, 2, 1, 6\}$ contain the same numbers as the product of $\{1, 2\}$ and $\{1, 1, 3\}$: $\{1, 2\} \otimes \{1, 1, 3\} = \{1, 1, 3, 2, 2, 6\}$. That is, the set $\{\gcd(k, 6)\}$, $k = 1, 2, 3, 4, 5, 6$, equals the set $\{\gcd(k, 2)\}$, $k = 1, 2$, times the set $\{\gcd(k, 3)\}$, $k = 1, 2, 3$. As a consequence, $P(6) = P(2) \cdot P(3)$. In general, if $\gcd(v, w) = 1$ then $P(vw) = P(v) \cdot P(w)$. Pillai's function being multiplicative is a consequence of the Euler totient function being multiplicative. Indeed for $n = vw$ and $\gcd(v, w) = 1$ we have

$$P(n) = P(vw) = \sum_{d|vw} d \varphi(vw/d) = \sum_{d_v|v} \sum_{d_w|w} d_v d_w \varphi(vw/d_v/d_w). \quad (13.5)$$

Since $\varphi(vw/d_v/d_w) = \varphi(v/d_v) \varphi(w/d_w)$ the latter can be elaborated to

$$P(vw) = \sum_{d_v|v} d_v \varphi(v/d_v) \sum_{d_w|w} d_w \varphi(w/d_w) = P(v) \cdot P(w). \quad (13.6)$$

Let us write the prime factorization of n as

$$n = \prod_{p_j|n} p_j^{\alpha_j}, \quad (13.7)$$

where $\alpha_j \geq 1$ is the largest power of prime p_j for which $p_j^{\alpha_j}$ is a divisor of n . Then the multiplicative nature of Pillai's function allows us to write

$$P(n) = \prod_{p_j|n} P(p_j^{\alpha_j}). \quad (13.8)$$

To obtain Pillai's function for a prime power we first take a look at $P(5) = 1+1+1+1+5$ and $P(5^2) = 1+1+1+1+5+1+1+1+1+5+1+1+1+1+5+1+1+1+1+5+1+1+1+1+25$. It follows that $P(5^2) = 5P(5) + 5^2 - 5$. Similarly, $P(5^3) = 5P(5^2) + 5^3 - 5^2$. The rule in these examples holds for any prime: $P(p^{\alpha+1}) = p \cdot P(p^\alpha) + p^{\alpha+1} - p^\alpha$. The latter implies

$$P(p^\alpha) = (\alpha + 1)p^\alpha - \alpha p^{\alpha-1}. \quad (13.9)$$

It can be proven by induction: For $\alpha = 0$ we have $P(p^0) = P(1) = 1 = (0 + 1)p^0 - 0 \cdot p^{-1}$ and for $\alpha + 1$ we have

$$\begin{aligned} P(p^{\alpha+1}) &= p \cdot P(p^\alpha) + p^{\alpha+1} - p^\alpha = (\alpha + 1)(p^{\alpha+1}) - \alpha p^\alpha + p^{\alpha+1} - p^\alpha \\ &= (\alpha + 2)(p^{\alpha+1}) - (\alpha + 1)p^\alpha \quad \square. \end{aligned} \quad (13.10)$$

From equations (13.9) and (13.8) it follows

$$P(n) = \prod_{p_j|n} (\alpha_j + 1)p_j^{\alpha_j} - \alpha_j p_j^{\alpha_j-1} \equiv \prod_{p_j|n} (\alpha_j(p_j - 1) + p_k) p_j^{\alpha_j-1}. \quad (13.11)$$

It offers a fast way to evaluate the Pillai function. For $n = 1, 2, 3, 4, 5, 6, 7, 8, \dots$ the Pillai values are $1, 3, 5, 8, 9, 15, 13, 20, \dots$. The latter is the sequence A018804 of the OEIS [2].

According to equation (13.9) $P(p^\alpha) > p^\alpha$, and therefore $P(n) > n$. To avoid orbits running to infinity, we create by means of Pillai's function the following iteration:

$$n_{k+1} = \frac{P(n_k)}{\gcd(n_k, P(n_k))}. \quad (13.12)$$

We will denote the underlying function as the \mathcal{P} function:

$$\mathcal{P}(n) = \frac{P(n)}{\gcd(n, P(n))}. \quad (13.13)$$

For instance, for $n = 6$ we obtain

$$\mathcal{P}(6) = \frac{P(6)}{\gcd(6, P(6))} = \frac{15}{\gcd(6, 15)} = \frac{15}{3} = 5. \quad (13.14)$$

13.2 Cycles of the \mathcal{P} function.

For starting values $n_0 \leq 10^9$ the iteration $n_{k+1} = \mathcal{P}(n_k)$ contains

one fixed point: $c_1 = (1)$,

two period 2 cycles: $c_2 = (13, 25)$ and

$$c_3 = (2758743, 10327625),$$

five period 3 cycles: $c_4 = (21, 65, 45)$,

$$c_5 = (31, 61, 121),$$

$$c_6 = (651, 3965, 5445),$$

$$c_7 = (1281, 7865, 1395) \text{ and}$$

$$c_8 = (2015, 2745, 2541),$$

two period 4 cycles: $c_9 = (377, 1425, 481, 1825)$ and

$$c_{10} = (70737, 295075, 1135953, 134125),$$

two period 6 cycles: $c_{11} = (403, 1525, 1573, 775, 793, 3025)$ and

$$c_{12} = (498945, 761463, 4544155, 15091947, 24544875, 2853059),$$

one period 12 cycle: $c_{13} = (11687, 86925, 58201, 56575, 22997, 172425, 14911, 111325,$

$$45617, 44175, 29341, 220825) \text{ and}$$

one period 14 cycle: $c_{14} = (12483, 37555, 486837, 402375, 23579, 177045, 262143,$

$$209235, 312075, 97643, 104025, 69745, 187245, 28971).$$

The elements of the cycles are all odd. An odd n implies all $p_j|n$ are odd, which implies all the $\alpha_j(p_j - 1) + p_j$ in equation (13.11) are odd, which on its turn implies all n 's successors $\mathcal{P}(n)$, $\mathcal{P}(\mathcal{P}(n))$, etc., are odd. So, if an element of a cycle is odd, then all elements of the cycle have to be odd. As a consequence, if an element of a cycle is even then all the elements have to be even. To investigate the latter possibility we consider the situation for even n . An even n will contain a factor 2^{α_1} . For a possible even factor in $P(n)$ we only have to consider the factor $p_1^{\alpha_1-1}(\alpha_1(p_1 - 1) + p_1) = 2^{\alpha_1-1}(\alpha_1 + 2)$.

Now we distinguish two cases: α_1 is odd and α_1 is even.

If α_1 is odd, then $\alpha_1 + 2$ is odd and the even factor in Pillai's function is 2^{α_1-1} . As a consequence $\gcd(n, P(n)) = 2^{\alpha_1-1}$ and $\mathcal{P}(n)$ will be odd.

If α_1 is even, then $\alpha_1 + 2$ is even and the even factor in Pillai's function is at least 2^{α_1} . As a consequence $\gcd(n, P(n)) = 2^{\alpha_1}$ and there will only be an even factor in $\mathcal{P}(n)$ if $\frac{\alpha_1 + 2}{2}$ is even. Since $\frac{\alpha_1 + 2}{2} < 2^{\alpha_1}$ for $\alpha_1 \geq 2$, the even factor of $\mathcal{P}(n)$ is smaller than the even factor of n . Each generated even number will therefore never equal one of its predecessors.

As a result we can conclude that a cycle with an even element is impossible.

13.3 Cycle combinations

The first element of cycle c_9 is $377 = 13 * 29$. We notate it as $c_9(1) = 377$. The first element of cycle c_5 is 31. We notate it as $c_5(1) = 31$. The product of 377 and 31 is 11687, which is the first element of cycle c_{13} . We therefore have $c_9(1) \cdot c_5(1) = c_{13}(1)$.

Since 1425 is the second element of cycle c_9 , and 61 is the second element of cycle c_5 and $1425 \cdot 61 = 86925$ is the second element of cycle c_{13} , we have $c_9(2) \cdot c_5(2) = c_{13}(2)$.

In total we obtain:

$$\begin{aligned}
 c_9(1) \cdot c_5(1) &= c_{13}(1), \\
 c_9(2) \cdot c_5(2) &= c_{13}(2), \\
 c_9(3) \cdot c_5(3) &= c_{13}(3), \\
 c_9(4) \cdot c_5(1) &= c_{13}(4), \\
 c_9(1) \cdot c_5(2) &= c_{13}(5), \\
 c_9(2) \cdot c_5(3) &= c_{13}(6), \\
 c_9(3) \cdot c_5(1) &= c_{13}(7), \\
 c_9(4) \cdot c_5(2) &= c_{13}(8), \\
 c_9(1) \cdot c_5(3) &= c_{13}(9), \\
 c_9(2) \cdot c_5(1) &= c_{13}(10), \\
 c_9(3) \cdot c_5(2) &= c_{13}(11), \\
 c_9(4) \cdot c_5(3) &= c_{13}(12).
 \end{aligned} \tag{13.15}$$

That is, the period 12 cycle c_{13} is a combination of period 4 cycle c_9 and period 3 cycle c_5 .

There are other combinations of cycles.

The period 3 cycle c_6 is a combination of period 3 cycle c_4 and period 3 cycle c_5 :

$$\begin{aligned} c_4(1) \cdot c_5(1) &= c_6(1), \\ c_4(2) \cdot c_5(2) &= c_6(2), \\ c_4(3) \cdot c_5(3) &= c_6(3). \end{aligned} \tag{13.16}$$

The period 3 cycle c_7 is a combination of period 3 cycle c_4 and period 3 cycle c_5 :

$$\begin{aligned} c_4(1) \cdot c_5(2) &= c_7(1), \\ c_4(2) \cdot c_5(3) &= c_7(2), \\ c_4(3) \cdot c_5(1) &= c_7(3). \end{aligned} \tag{13.17}$$

The period 3 cycle c_8 is a combination of period 3 cycle c_4 and period 3 cycle c_5 :

$$\begin{aligned} c_4(1) \cdot c_5(3) &= c_8(3), \\ c_4(2) \cdot c_5(1) &= c_8(1), \\ c_4(3) \cdot c_5(2) &= c_8(2). \end{aligned} \tag{13.18}$$

The period 6 cycle c_{11} is a combination of period 2 cycle c_2 and period 3 cycle c_5 :

$$\begin{aligned} c_2(1) \cdot c_5(1) &= c_{11}(1), \\ c_2(2) \cdot c_5(2) &= c_{11}(2), \\ c_2(1) \cdot c_5(3) &= c_{11}(3), \\ c_2(2) \cdot c_5(1) &= c_{11}(4), \\ c_2(1) \cdot c_5(2) &= c_{11}(5), \\ c_2(2) \cdot c_5(3) &= c_{11}(6). \end{aligned} \tag{13.19}$$

Ignoring that cycle dimensions do not allow c_{12} as a combination of c_{14} and c_5 , we obtain the following:

$$\begin{aligned} c_{14}(1) \cdot c_5(2) &= c_{12}(2), \\ c_{14}(2) \cdot c_5(3) &= c_{12}(3), \\ c_{14}(3) \cdot c_5(1) &= c_{12}(4), \\ c_{14}(4) \cdot c_5(2) &= c_{12}(5), \\ c_{14}(5) \cdot c_5(3) &= c_{12}(6), \\ c_{14}(6) \cdot c_5(1) &= 11 \cdot c_{12}(1), \\ c_{14}(7) \cdot c_5(2) &= 3 \cdot 7 \cdot c_{12}(2), \\ c_{14}(8) \cdot c_5(3) &= \frac{3 \cdot 13}{7} \cdot c_{12}(3), \\ &\vdots \end{aligned} \tag{13.20}$$

The first five equalities seem hopeful for some sort of combination, but then things break down.

Anyway, the union of all prime power factors of all elements of all cycles is the set $\{3, 3^2, 3^3, 5, 5^2, 5^3, 7, 11, 11^2, 13, 17, 19, 29, 31, 37, 61, 73\}$.

13.4 Statistics of cycle arrivals

For $n_0 \leq 10^k$ with $k = 3, 4, 5, 6, 7, 8$, the number of starting values for which the orbit ends in a cycle are shown in the next table.

cycle	$n_0 \leq 10^3$	$n_0 \leq 10^4$	$n_0 \leq 10^5$	$n_0 \leq 10^6$	$n_0 \leq 10^7$	$n_0 \leq 10^8$
c_1	1	1	1	1	1	1
c_2	300	2189	16 387	127 175	1 029 420	8 757 731
c_3	0	0	2	110	2415	38 261
c_4	43	226	1364	9842	78 086	647 030
c_5	4	41	433	4388	40 243	359 671
c_6	6	57	374	3324	31 183	314 522
c_7	4	50	357	2783	24 750	228 999
c_8	2	27	290	3000	29 728	296 019
c_9	450	4688	45 824	439 902	4 241 676	41 039 799
c_{10}	0	37	957	15374	210 249	2 619 968
c_{11}	96	831	7695	70 411	652 854	6 131 639
c_{12}	0	1	151	3583	63 376	919 061
c_{13}	15	522	7628	94 458	1 042 165	11 047 228
c_{14}	79	1330	18 537	225 649	2 553 854	27 600 071

13.5 Statistics of untouchables

If we start with $n_0 = 2$, then the orbit is 2, 3, 5, 9, 7, 13, ... So, if we start with numbers smaller than 4, the numbers 1, 3, 5, and 7 are touchable, while the numbers 2, 4, 6, 8, etc. are untouchable. For $n_0 = 4$ the orbit is 4, 2, 3, 5, 9, 7, 13, ... That is, for starting number 4 the number 2 is no longer untouchable. As usual, we keep track of the smallest starting number t_n for which a number n is no longer untouchable.

If we start with numbers smaller than 10^3 , the first part of the list of t_n is:

1, 4, 2, 64, 2, 60, 2, ?, 2, 12, 41, 960, 2, 36, 120, ?, 14, 20, 34, 192, 11, 324, ?, ?, 13, 28, 10, 576, 711, ?, 121, ?, 14, 500, 14, 320, 14, 196, 14, ?, ?, 44, ?, ?, 23, ?, ?, ?, 34, 52, ...

From $s_4 = 64$ we see that 4 becomes untouchable for the first time if the starting value is 64. The question marks show that for starting numbers smaller than 1000 the numbers 8, 16, 23, 24, 30, 32, 40, 41, 43, 44, 46, 47, 48 ... are untouchable. Question marks may disappear by taking larger starting numbers.

For starting numbers smaller than 10^7 the first part of the list of t_n is as follows:

1, 4, 2, 64, 2, 60, 2, 16384, 2, 12, 41, 960, 2, 36, 120, ?, 14, 20, 34, 192, 11, 324, 59049, 245760, 13, 28, 10, 576, 711, 16380, 121, ?, 14, 500, 14, 320, 14, 196, 14, 49152, 1271, 44, 20434, 5184, 23, 236196, ?, ?, 34, 52, ...

Several question marks have disappeared. The first question mark now is for $n = 16$.

If we only start with numbers from the set $\{1, 2, 3, 4\}$, then 4 is the only untouchable element. The ratio of the number of untouchables and set length is $1/4$. Let u_n be the number of elements of the set $\{1, 2, 3, \dots, n\}$ which are untouchable if we only start with numbers from the set $\{1, 2, 3, \dots, n\}$. The ratio of untouchables and set length is u_n/n . For numbers up to 10^7 the ratio u_n/n is plotted against n in the next figure.

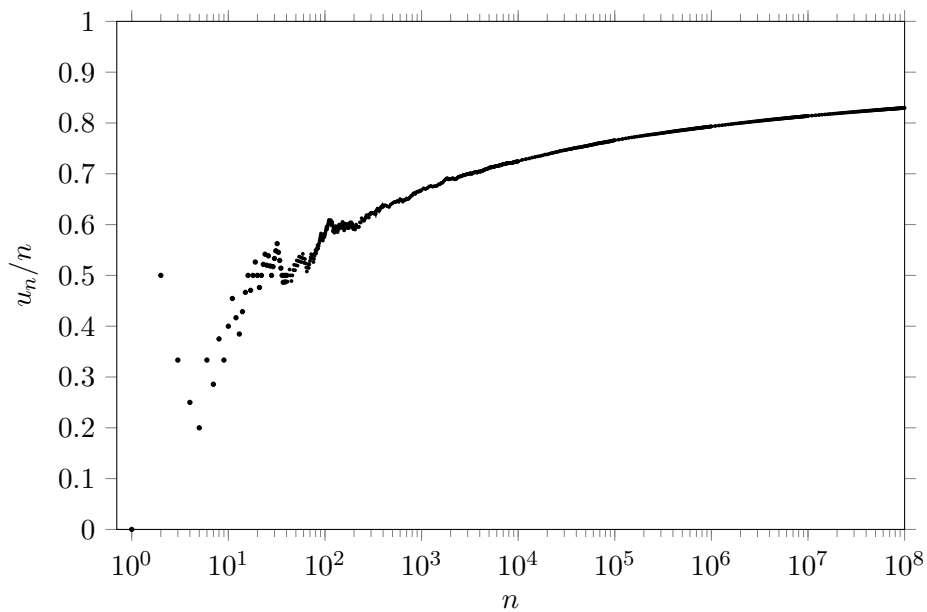

Figure 13.1: The ratio u_n/n for the \mathcal{P} function.

The question arises: What will be the value of $\lim_{n \rightarrow \infty} \frac{u_n}{n}$?

13.6 Statistics of distances

For instance, the orbit 2, 3, 5, 9, 7, 13 implies $D(2) = 5$. The distribution of distances is shown in the next figure.

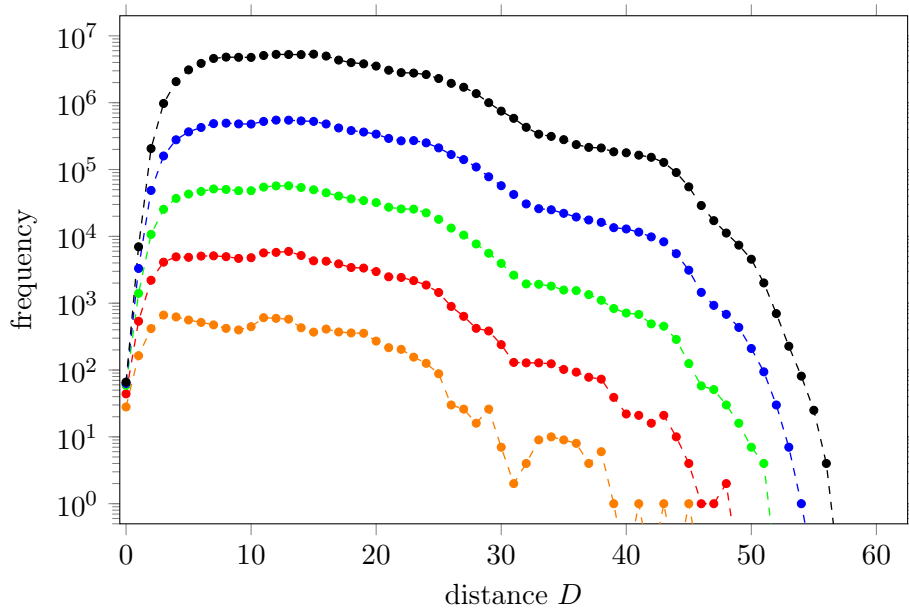

Figure 13.2: Distribution of distances for starting numbers smaller than or equal to: 10^4 (orange), 10^5 (red), 10^6 (green), 10^7 (blue), 10^8 (black).

13.7 Records of maximums

For starting number 2 we have the orbit 2, 3, 5, 9, 7, 13, 25, 13, ... Since the orbit never leaves the cycle $c_2 = (13, 25)$, the maximum value of the orbit is 25: $M(2) = 25$. It is a maximum record since $M(1) = 1$. It turns out that $M(n) = 25$ for $n = 3, 4, 5, 6, 7, 8$ and 9. For starting number 10 we have the orbit 10, 27, 3, 5, 9, 7, 13, 25, 13, ... That is, $M(10) = 27$, which is a new maximum record. Continuing the search we find the next maximum record for $n = 11$: $M(11) = 65$, and so on. The maximum records are tabulated below for $n \leq 10^9$.

#	n	M record	#	n	M record	#	n	M record
1	1	1	14	19 198	602 248 075	27	5 070 331	4 129 546 655 637
2	2	25	15	45 691	959 109 375	28	7 470 479	5 107 319 823 177
3	10	27	16	84 467	5 182 970 625	29	8 424 961	8 449 565 753 475
4	11	65	17	126 691	9 212 646 375	30	11 022 962	10 788 553 771 875
5	14	1825	18	137 073	17 583 671 875	31	11 116 562	18 216 757 288 125
6	29	13 797	19	186 437	23 220 390 625	32	13 807 831	19 402 011 657 909
7	74	486 837	20	253 382	25 694 585 917	33	21 242 577	23 541 461 598 375
8	331	802 845	21	380 073	49 412 665 225	34	21 894 478	69 900 648 191 649
9	662	1 271 875	22	451 153	72 872 017 075	35	36 091 262	135 348 136 171 875
10	2297	2 429 973	23	868 129	324 498 671 875	36	41 934 721	1 586 828 448 502 605
11	3062	4 673 025	24	1 330 257	1 013 947 890 417	37	285 435 047	4 340 378 636 015 625
12	3959	58 907 277	25	2 604 387	1 529 779 453 125	38	760 800 842	37 474 339 083 671 875
13	9599	110 653 125	26	3 927 422	3 014 172 578 725	39		

The records of orbit maximums have been plotted against the starting numbers $n \leq 10^9$ in the next figure.

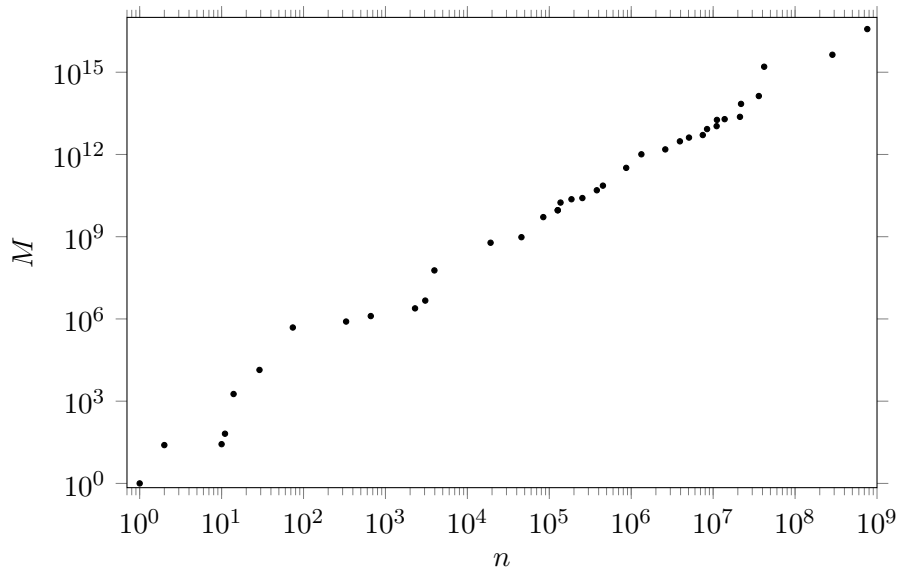

Figure 13.3: The records of orbit maximums M plotted against starting value n .

For starting value 2 the orbit is 2, 3, 5, 9, 7, 13, 25, 13, ... Its maximum, 25, is a maximum record which occurs on the seventh position of the orbit. In the next figure the position of a maximum record in an orbit is plotted against the starting value of the orbit.

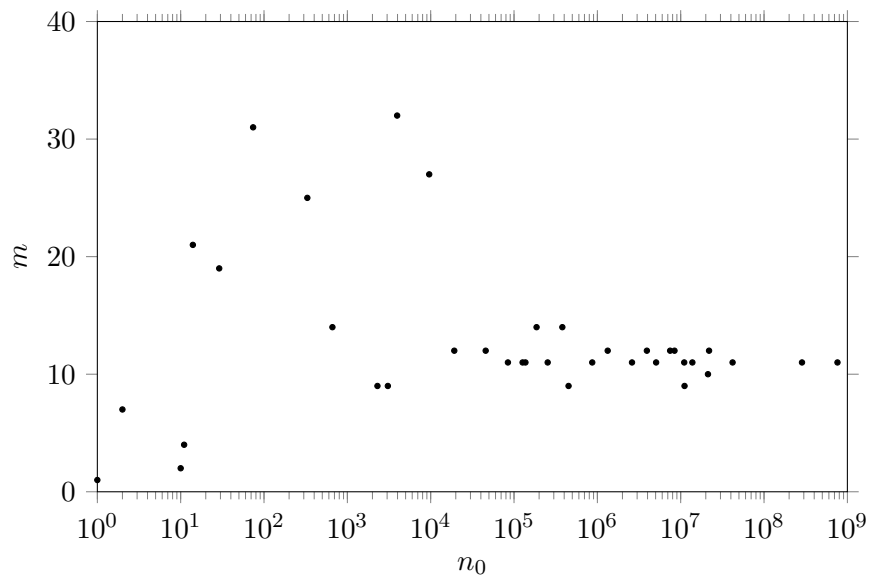

Figure 13.4: The m th position of a maximum record in an orbit against the starting value of the orbit.

The position of a maximum record in an orbit seems to be quite independent of the starting value of the orbit; the correlation is approximately -0.067 .

13.8 Records of distances

For $n = 2$ the orbit is 2, 3, 5, 9, 7, 13, 25, 13, ... Thus the distance is 5: $D(2) = 5$. For $n = 3$ the distance is 4. For $n = 4$ the orbit is 4, 2, 3, etc. That is, $D(4) = 6$, which is a new distance record. The distance records are tabulated below for $n \leq 10^9$.

#	n	D record	#	n	D record	#	n	D record
1	2	5	11	1009	34	21	1 371 899	52
2	4	6	12	1199	35	22	2 057 849	53
3	12	7	13	1207	36	23	6 654 391	54
4	14	17	14	3967	39	24	14 909 397	55
5	36	18	15	5431	43	25	32 514 996	56
6	51	19	16	7369	45	26	109 625 669	58
7	87	23	17	66 889	48	27	862 305 881	59
8	198	24	18	110 218	49	28		
9	454	25	19	381 919	50	29		
10	947	27	20	732 818	51	30		

13.9 Successive even numbers

From second section of this chapter we recall that an even n will contain a factor 2^{α_1} with α_1 a positive integer and that the contribution to Pillai's function is $2^{\alpha_1-1}(\alpha_1 + 2)$. If α_1 is odd then 2^{α_1} and $2^{\alpha_1-1}(\alpha_1 + 2)$ will have 2^{α_1-1} in common. As a consequence, for odd α_1 there is no even factor in $\mathcal{P}(n)$. We will state it as a rule:

rule 1: If $n = 2^{2m+1}$ then $\mathcal{P}(n)$ is odd.

If α_1 is even, then $n = 2^{\alpha_1}$ and Pillai's function $2^{\alpha_1-1}(\alpha_1 + 2)$ will have 2^{α_1} in common. The factor in $\mathcal{P}(n)$ will be $\alpha_1/2 + 1$ for as far it is not divided by a divisor of n . Therefore $\mathcal{P}(n)$ will not contain an even factor if $\alpha_1/2$ is even. We state it as a rule:

rule 2: If n contains a factor 2^{4m} then $\mathcal{P}(n)$ is odd.

The remaining possibility, $\alpha_1 = 4m + 2$ will be split into $\alpha_1 = 8m + 2$ and $\alpha_1 = 8m + 6$. For $\alpha_1 = 8m + 2$ we have $\alpha_1/2 + 1 = 2(2m + 1)$. So, there is a factor 2^1 in $\mathcal{P}(n)$. Because of rule 1 $\mathcal{P}(\mathcal{P}(n))$ is odd. As a rule:

rule 3: If n contains a factor 2^{8m+2} then $\mathcal{P}(n)$ contains a factor 2^1 and, because of rule 1, $\mathcal{P}(\mathcal{P}(n))$ is odd.

The remaining possibility, $\alpha_1 = 8m + 6$ will be split into $\alpha_1 = 16m + 6$ and $\alpha_1 = 16m + 14$. For $\alpha_1 = 16m + 6$ we have $\alpha_1/2 + 1 = 4(2m + 1)$. So, there is a factor 2^2 in $\mathcal{P}(n)$. Because of rule 3 $\mathcal{P}(\mathcal{P}(n))$ contains a factor 2^1 and $\mathcal{P}(\mathcal{P}(\mathcal{P}(n)))$ is odd. As a rule:

rule 4: If n contains a factor 2^{16m+6} then $\mathcal{P}(n)$ contains a factor 2^2 and, because of rule 3, $\mathcal{P}(\mathcal{P}(n))$ contains a factor 2^1 and $\mathcal{P}(\mathcal{P}(\mathcal{P}(n)))$ is odd.

The remaining possibility, $\alpha_1 = 16m + 14$ will be split into $\alpha_1 = 32m + 14$ and $\alpha_1 = 32m + 30$. For $\alpha_1 = 32m + 14$ we have $\alpha_1/2 + 1 = 8(2m + 1)$. So, there is a factor 2^3 in $\mathcal{P}(n)$. Because of rule 1 $\mathcal{P}(\mathcal{P}(n))$ is odd. As a rule:

rule 5: If n contains a factor 2^{32m+14} then $\mathcal{P}(n)$ contains a factor 2^3 and, because of rule 1, $\mathcal{P}(\mathcal{P}(n))$ is odd.

The remaining possibility, $\alpha_1 = 32m + 30$ will be split into $\alpha_1 = 64m + 30$ and $\alpha_1 = 64m + 62$. For $\alpha_1 = 64m + 30$ we have $\alpha_1/2 + 1 = 16(2m + 1)$. So, there is a factor 2^4 in $\mathcal{P}(n)$. Because of rule 2 $\mathcal{P}(\mathcal{P}(n))$ is odd. As a rule:

rule 6: If n contains a factor 2^{64m+30} then $\mathcal{P}(n)$ contains a factor 2^4 and, because of rule 2, $\mathcal{P}(\mathcal{P}(n))$ is odd.

The remaining possibility, $\alpha_1 = 64m + 62$ will be split into $\alpha_1 = 128m + 62$ and $\alpha_1 = 128m + 126$. For $\alpha_1 = 128m + 62$ we have $\alpha_1/2 + 1 = 32(2m + 1)$. So, there is a factor 2^5 in $\mathcal{P}(n)$. Because of rule 1 $\mathcal{P}(\mathcal{P}(n))$ is odd. As a rule:

rule 7: If n contains a factor $2^{128m+62}$ then $\mathcal{P}(n)$ contains a factor 2^5 and, because of rule 1, $\mathcal{P}(\mathcal{P}(n))$ is odd.

The remaining possibility, $\alpha_1 = 128m + 126$ will be split into $\alpha_1 = 256m + 126$ and $\alpha_1 = 256m + 254$. For $\alpha_1 = 256m + 126$ we have $\alpha_1/2 + 1 = 64(2m + 1)$. So, there is a factor 2^6 in $\mathcal{P}(n)$. Because of rule 4 $\mathcal{P}(\mathcal{P}(n))$ contains a factor 2^2 and $\mathcal{P}(\mathcal{P}(\mathcal{P}(n)))$ contains a factor 2^1

and $\mathcal{P}(\mathcal{P}(\mathcal{P}(\mathcal{P}(n))))$ is odd. As a rule:

rule 8: If n contains a factor $2^{256m+126}$ then $\mathcal{P}(n)$ contains a factor 2^6 and, because of rule 4, $\mathcal{P}(\mathcal{P}(n))$ contains a factor 2^2 , $\mathcal{P}(\mathcal{P}(\mathcal{P}(n)))$ contains a factor 2^1 and $\mathcal{P}(\mathcal{P}(\mathcal{P}(\mathcal{P}(n))))$ is odd.

Once one comprehends the regularity, the remaining rules can be stated without analysis and solely by referring to previous rules:

rule 9: If n contains a factor $2^{512m+254}$ then $\mathcal{P}(n)$ contains a factor 2^7 and, because of rule 1, $\mathcal{P}(\mathcal{P}(n))$ is odd.

rule 10: If n contains a factor $2^{1024m+510}$ then $\mathcal{P}(n)$ contains a factor 2^8 and, because of rule 2, $\mathcal{P}(\mathcal{P}(n))$ is odd.

rule 11: If n contains a factor $2^{2048m+1022}$ then $\mathcal{P}(n)$ contains a factor 2^9 and, because of rule 1, $\mathcal{P}(\mathcal{P}(n))$ is odd.

rule 12: If n contains a factor $2^{4096m+2046}$ then $\mathcal{P}(n)$ contains a factor 2^{10} and, because of rule 3, $\mathcal{P}(\mathcal{P}(n))$ contains a factor 2^1 and $\mathcal{P}(\mathcal{P}(\mathcal{P}(n)))$ is odd.

rule 13: If n contains a factor $2^{8192m+4094}$ then $\mathcal{P}(n)$ contains a factor 2^{11} and, because of rule 1, $\mathcal{P}(\mathcal{P}(n))$ is odd.

rule 14: If n contains a factor $2^{16384m+8190}$ then $\mathcal{P}(n)$ contains a factor 2^{12} and, because of rule 2, $\mathcal{P}(\mathcal{P}(n))$ is odd.

rule 15: If n contains a factor $2^{32768m+16322}$ then $\mathcal{P}(n)$ contains a factor 2^{13} and, because of rule 1, $\mathcal{P}(\mathcal{P}(n))$ is odd.

The list of rules goes on and on. For even α_1 , thus for rules 2 and larger, the regularity is: If n contains a factor $2^{2^r m + 2^{r-1} - 2}$ then $\mathcal{P}(n)$ contains a factor 2^{r-2} .

By means of the latter regularity we will search for records of lengths of rows with even numbers. The smallest starting value n for which $\mathcal{P}(n)$ does not contain an even factor is $n = 2$. Then $\mathcal{P}(n)$ is odd. To obtain the smallest n for which $\mathcal{P}(n)$ contains a factor 2 we substitute $r = 3$ in $2^{2^r m + 2^{r-1} - 2}$. The result is $2^{2^3 m + 2^2 - 2}$. For $m = 0$ this is $2^{2^2 - 2} = 2^2$. So, for $n = 2^2 = 4$ the next iterate is $\mathcal{P}(n)$ will contain a factor 2. To obtain the smallest n for which $\mathcal{P}(n)$ contains a factor 2^2 we substitute $r = 4$ in $2^{2^r m + 2^{r-1} - 2}$. The result is

$2^{2^4m+2^3-2}$. For $m = 0$ this is $2^{2^3-2} = 2^6$. So, for $n = 2^6 = 64$ the next iterate is $\mathcal{P}(n)$ will contain a factor 2^2 . To obtain the smallest n for which $\mathcal{P}(n)$ contains a factor 2^6 we substitute $r = 8$ in $2^{2^r m + 2^{r-1} - 2}$. The result is $2^{2^8 m + 2^7 - 2}$. For $m = 0$ this is $2^{2^7 - 2} = 2^{126}$. So, for $n = 2^{126} = 85070591730234615865843651857942052864$ the next iterate is $\mathcal{P}(n)$ will contain a factor 2^6 . To obtain the smallest n for which $\mathcal{P}(n)$ contains a factor 2^{126} we substitute $r = 128$ in $2^{2^r m + 2^{r-1} - 2}$. The result is $2^{2^{128} m + 2^{127} - 2}$. For $m = 0$ this is $2^{2^{127} - 2} = 2^{170141183460469231731687303715884105726}$. So, for $n = 2^{170141183460469231731687303715884105726}$ the next iterate is $\mathcal{P}(n)$ will contain a factor 2^{126} .

In summary, starting with $n_0 = 2^{170141183460469231731687303715884105726}$ the iterate n_1 contains a factor $2^{126} = 85070591730234615865843651857942052864$, the iterate n_2 will contain a factor 64, the iterate n_3 will contain a factor 4, the iterate n_4 will contain a factor 2 and the iterate n_5 will be odd. So, for the first row with 5 successive even numbers we have to start with the huge number $n_0 = 2^{170141183460469231731687303715884105726}$.

Briefly, if $n_m = 2$, then $n_{m-1} = 2^{2n_m-2}$, $n_{m-2} = 2^{2n_{m-1}-2}$, $n_{m-3} = 2^{2n_{m-2}-2}$, $n_{m-4} = 2^{2n_{m-3}-2}$, and so on. Explicitly, if $n_4 = 2^1$, then

$$n_3 = 2^{(2^2-2)}, \quad n_2 = 2^{(2^{(2^2-1)}-2)}, \quad n_1 = 2^{(2^{(2^{(2^2-1)}-1)}-2)} \quad \text{and}$$

$$n_0 = 2^{(2^{(2^{(2^{(2^2-1)}-1)}-1)}-2)}.$$

For the latter case the orbit starting with n_0 is:

$$2^{170141183460469231731687303715884105726}, 2^{126}, 64, 4, 2, 3, 5, 9, 7, 13, 25, 13, \dots$$

For the record:

$n = 2$ is the smallest number for which the orbit has a row of 1 even number,

$n = 4$ is the smallest number for which the orbit has a row of 2 even numbers,

$n = 64$ is the smallest number for which the orbit has a row of 3 even numbers,

$n = 2^{126}$ is the smallest number for which the orbit has a row of 4 even numbers, and

$n = 2^{170141183460469231731687303715884105726}$ is the smallest number for which the orbit has a row of 5 even numbers.

Bibliography

- [1] E. Roosendaal, *On the $3x + 1$ Problem*,
<http://www.ericr.nl>
- [2] N.J.A. Sloane, *The Online Encyclopedia of Integer Sequences*,
<https://oeis.org>
- [3] R.K. Guy and J.L. Selfridge, What Drives an Aliquot Sequence?, *Math. of Comp.*, **29**, 101-107 (1975).
- [4] E. Cesàro, Sur une formule empirique de M. Pervouchine, *C. R. Math. Acad. Sci. Paris*, **119**, 848-849 (1894).
- [5] S. Takahashi et al., *Curious Properties of Iterative Sequences*,
<https://doi.org/10.48550/arXiv.2308.06691>